

## **1 ABOUT THIS GUIDE**

Welcome to the ST9+ User Guide. The aim of this book is to help you to get a working knowledge of the ST9+ microcontroller family. Using this foundation, you will be in a good position to understand and implement any of the ST9+ microcontrollers. To make it easier, we have selected the major technical concepts of the ST9+ family and will introduce them gradually over several chapters, always supporting theory with practical examples.

### **1.1 PREREQUISITES**

This book addresses application developers. To fully benefit from the book content, you should be familiar with microcontrollers and their associated development tools.

For basic information on microcontrollers and development tools, you should refer to one of the many introductory books available on the subject.

### **1.2 RESULTS**

The book will provide you with:

- A basic understanding of the ST9+ microcontroller family
- Knowledge and ready-to-use examples on using ST9+ peripherals
- Useful tips and warnings

---

# Table of Contents

---

<b>1 ABOUT THIS GUIDE</b>	<b>1</b>
1.1 PREREQUISITES	1
1.2 RESULTS	1
1.3 HOW TO USE THIS GUIDE	5
1.4 COMPANION SOFTWARE	5
1.5 ABOUT THE AUTHORS	5
1.6 RELATED DOCUMENTS	6
<b>2 INTRODUCING THE ST9+ BASICS</b>	<b>6</b>
2.1 PROCESSOR CORE	6
2.2 PERIPHERALS	7
2.2.1 ST90158	8
2.2.2 ST90135	8
2.2.3 ST92F120	9
<b>3 PROCESSOR CORE: MAIN CONCEPTS</b>	<b>10</b>
3.1 ADDRESS SPACES	10
3.1.1 Register-Oriented Programming Model	10
3.1.2 Register File	11
3.1.3 Direct access to the Register File	11
3.1.4 Working Registers	12
3.1.5 Peripheral Register Pages	12
3.1.6 Working Registers and Register Pointers	12
3.1.7 Memory Management Unit	18
3.2 STACK MODES	26
3.3 INSTRUCTION SET	28
3.3.1 Overview	28
3.3.2 Advantages when Using C Language	35
3.4 INTERRUPTS	37
3.4.1 Interrupt Vectors	37
3.4.2 Interrupt Priorities	41
3.4.3 External Interrupt Unit	46
3.5 DMA CONTROLLER	50
3.5.1 Overview	50
3.5.2 How the DMA Works	51
3.6 RESET AND CLOCK CONTROL UNIT (RCCU)	53
3.6.1 Clock Control Unit	53
3.6.2 Reset and Stop Manager	57

---

# Table of Contents

---

<b>4 USING THE ON-CHIP PERIPHERALS</b>	<b>57</b>
4.1 PROGRAMMING THE CORE AND PERIPHERALS	57
4.2 PARALLEL I/O	59
4.3 STANDARD AND WATCHDOG TIMERS	60
4.3.1 Description	60
4.3.2 Timer Application for Periodic Interrupts	64
4.3.3 Watchdog Application 1: Generating a PWM	65
4.3.4 Watchdog Application 2: Using the Watchdog	66
4.4 MULTIFUNCTION TIMER	67
4.4.1 Generating Two Pulse Width Modulated Waves with One MFT	71
4.4.2 Generating a Pulse Width Modulated Wave with a Cleaner Spectrum	74
4.4.3 Incremental Encoder Counter	76
4.4.4 MFT Application 1: Generating 2 PWMs using Interrupts	78
4.4.5 MFT Application 2: Generating a PWM using DMA	78
4.4.6 MFT Application 3: Generating a PWM using the DMA Swap Mode	79
4.5 SERIAL PERIPHERAL INTERFACE	79
4.5.1 Description	79
4.5.2 Static Liquid-Crystal Display Interface Example	80
4.5.3 EEPROM Serial Interface Example using I <sup>2</sup> C	82
4.6 SERIAL COMMUNICATIONS INTERFACE	84
4.6.1 Description	84
4.6.2 SCI Application 1: Sending Bytes using Interrupts	89
4.6.3 SCI Application 2: Sending Bytes using DMA	89
4.6.4 SCI Application 3: Sending and Receiving Bytes using DMA	89
4.6.5 SCI Application 4: Matching Input Bytes	89
4.7 ANALOG TO DIGITAL CONVERTER	90
4.7.1 Description	90
4.7.2 Analog Watchdog	92
4.7.3 Interrupt Vectoring	92
4.7.4 ADC Application: A/D Conversions and Analog Watchdog using Interrupts	93
4.8 PERIPHERAL INITIALIZATION	93
4.8.1 initialization Header File	93
4.8.2 Peripheral Function File	94
<b>5 USING THE DEVELOPMENT TOOLS</b>	<b>104</b>
5.1 DEVELOPING IN C LANGUAGE	104
5.2 AVAILABLE TOOLS	104
5.3 INTRODUCING THE DEVELOPMENT TOOLS	105

---

# Table of Contents

---

5.4	PROGRAM CONFIGURATION AND INITIALISATION .....	106
5.4.1	Writing the Makefile .....	106
5.4.2	Writing the Linker Command File using a Script File .....	111
5.4.3	Writing the Start-Up File .....	113
5.5	GLOBAL INITIALISATION: CORE AND PERIPHERALS .....	121
5.5.1	Core Initialisation .....	121
5.5.2	Peripheral Initialisation .....	121
5.5.3	Port Initialisation .....	122
5.5.4	Final Initialisation .....	122
5.6	INTERRUPT CONSIDERATIONS .....	122
<b>6</b>	<b>DETAILED BLOCK DIAGRAMS .....</b>	<b>122</b>
6.1	EXTERNAL INTERRUPT CONTROLLER .....	123
6.2	TOP-LEVEL INTERRUPT INPUT .....	124
6.3	WATCHDOG TIMER .....	125
6.4	MULTIFUNCTION TIMER .....	126
<b>7</b>	<b>GLOSSARY .....</b>	<b>129</b>
<b>8</b>	<b>INDEX .....</b>	<b>134</b>

### 1.3 HOW TO USE THIS GUIDE

As a first approach, we recommend that you study each chapter in sequence and carry out the exercises at each step.

### 1.4 COMPANION SOFTWARE

A downloadable file entitled ST9+ User Guide Companion Software is available. This file provides all the source text files, listings, object files and any other files mentioned in the document.

You can download the ST9+ User Guide Companion Software from the <http://www.st.com> website product support page. Unless otherwise specified, all the examples can be compiled either for the ST90158 or ST92F120 by modifying the makefile and the "device.h" file, if included in the application directory.

### 1.5 ABOUT THE AUTHORS

This User Guide has been initially written by Jean-Luc Grégoriadès and Jean-Marc Delaplace and revised for the ST9+ by Jean-Luc Crébouw.

#### Jean-Luc Crébouw

A signal processing engineer, he has developed a voice synthesizer with an ST9+ and conducts ST9 training programs. He acts as a field application engineer consultant for all STMicroelectronics microcontrollers.

#### Jean-Marc Delaplace

A former electronics design engineer, he has worked throughout his career for various U.S. companies involved in lab automation equipment. He has used microprocessors since they first appeared on the market and programmed microcontrollers of various brands in industrial applications using both assembler and high-level languages.

#### Jean-Luc Grégoriadès

Teaches automated systems and industrial computer science at the Electrical Engineering department of the University of Cergy-Pontoise. He introduced the STMicroelectronics ST6 as a teaching base for his microcontroller course. On this occasion, he wrote with his friend J.M Delaplace, the book "Le ST6: Etude progressive d'un microcontrôleur" published at "Editions DUNOD".

### 1.6 RELATED DOCUMENTS

The following reference documents should be available for additional information:

- ST9 Datasheet
- ST9+ Programming Manual
- ST9 Family GNU Software tools
- ST9 GNU C Toolchain Release note
- ST9 Family GNU C Compiler
- GNU Make Utility

You can get a current list of documentation at <http://www.st.com>.

## 2 INTRODUCING THE ST9+ BASICS

The ST9+ microcontroller family has a common processor core surrounded by a range of powerful peripherals for interfacing with many different devices. The peripherals have sufficient built-in intelligence to be able to perform even complex jobs on their own, freeing the core almost entirely from I/O handling. The core can thus be fully utilized for classical microprocessing tasks.

The ST9+ architecture is an original STMicroelectronics design, with the objective of providing an innovative and efficient microcontroller architecture dedicated to real-time control.

### 2.1 PROCESSOR CORE

When you compare different microcontrollers, you can estimate the relative computing power of the core, and also of the peripherals (if they include some intelligence). In some architectures, the peripherals make heavy use of the core and thus take up a part of its computing power. Many microcontrollers available on the market have a relatively powerful core, surrounded by very simple peripherals. This approach has the advantage of making the peripherals easy to use and configure, but at the expense of the overall computing power.

The ST9+ is an example of a radically different compromise. Its core is among the best 8-bit microprocessors on the market in terms of computing performance and system management capabilities. It is assisted (rather than just surrounded) by peripheral blocks of which most can perform complex tasks without the intervention of the core. The net result is a powerful machine that can even perform impressive tasks just using its peripherals. The three applications described in this book give meaningful examples of processes handled solely by the peripherals.

The ST9+ is the latest generation of the powerful ST9 microprocessor family. The ST9+ core executes software more than three times faster than the ST9 core using optimized instructions and up to double the CPU frequency. The core as well as many peripherals have been en-

hanced, like for example, the Memory Management Unit (MMU), which is now more flexible, with a single 4-Mbyte memory space that is directly accessible without using bank switching. Another example is the Reset and Clock Control Unit (RRCU) which has added features for reducing power-consumption.

The ST9+ is a register-oriented machine. This means that a large number of registers is available in the core; but above all, this implies that the instruction set is tailored to make efficient use of its registers through optimized addressing modes. It is also well suited to the use of C language.

## 2.2 PERIPHERALS

The ST9+ family includes a large number of peripherals. The main ones are:

Acronym	Name	Function
MFT	Multi-Function Timer	All counting and timing functions. Includes auto-reload on condition, interrupt generation, DMA transfer, two inputs for frequency measurement or pulse counting, two outputs that can change on condition, PWM signal generation. Conditions include: overflow/underflow, comparison with one or two compare registers. Capture registers used to record transitions on inputs with their time of occurrence.
SCI	Serial Communication Interface	Asynchronous transfer with either internal bit-rate generation or an external clock. Parity generation/detection. Address recognition feature that can request an interrupt on match of an input character. DMA transfer.
SPI	Serial Peripheral Interface	Serial input or output register, with internal or external clock. Intended for I/O expansion, or synchronous serial external device such as serial EEPROM (I <sup>2</sup> C and SPI protocol).
WDT	Watchdog timer	Can be used either as a watchdog or as a timer with input and output capable of pulse counting or waveform generation.
I/O port	Parallel input/output port	Parallel input/output ports. Each bit individually configurable as input, output, bi-directional, or alternate function. Inputs can be high impedance or with pull-up, CMOS or TTL-level. Outputs can have open drain or push-pull configuration.
ADC	Analog to digital converter.	Eight-bit analog to digital converter. One to eight channels can be converted in series. On each of two of the eight channels, an Analog Watchdog function is used to define two thresholds. When exceeded, an interrupt is generated.

These peripherals are available with the standard variants. More peripherals are available on custom devices on request, e.g. a videotext decoding logic.

The ST9+ family includes so many variants it would go beyond the scope of this book to describe them all. They are all made up of the same ST9+ core surrounded by a set of periph-

erals, ROM and/or RAM and/or EEPROM and/or FLASH being optional. This book has chosen to show the three most generic variants and provide a basis for understanding all the others.

2.2.1 ST90158

Figure 1. ST90158 Block Diagram

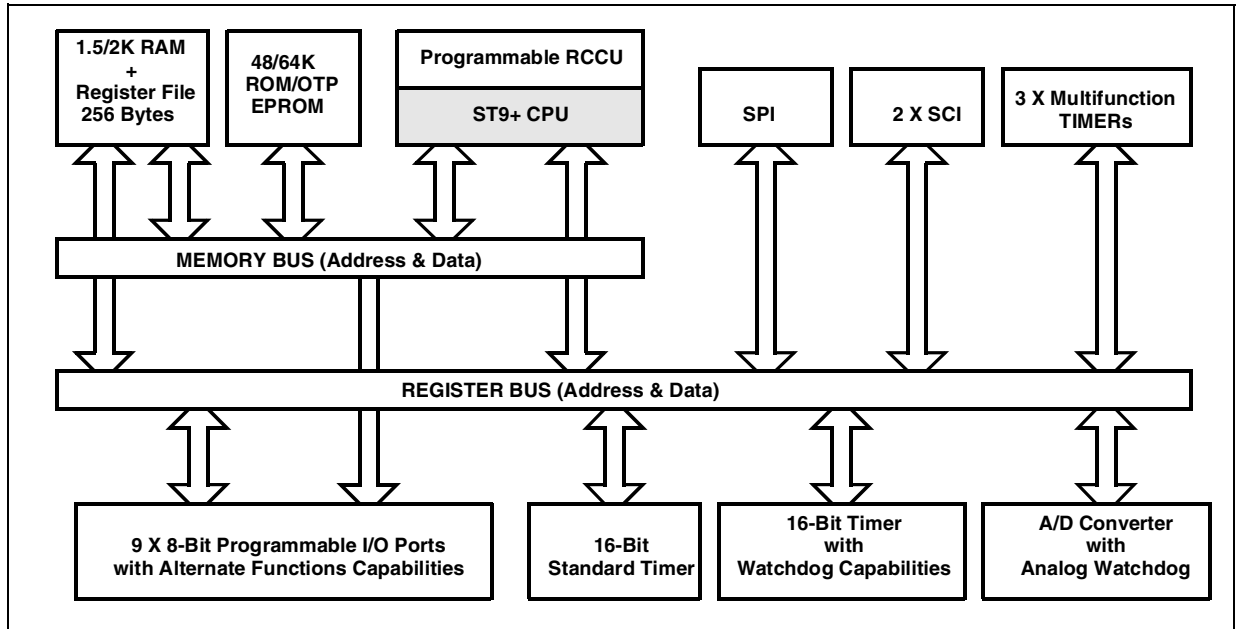

2.2.2 ST90135

Figure 2. ST90135 Block Diagram

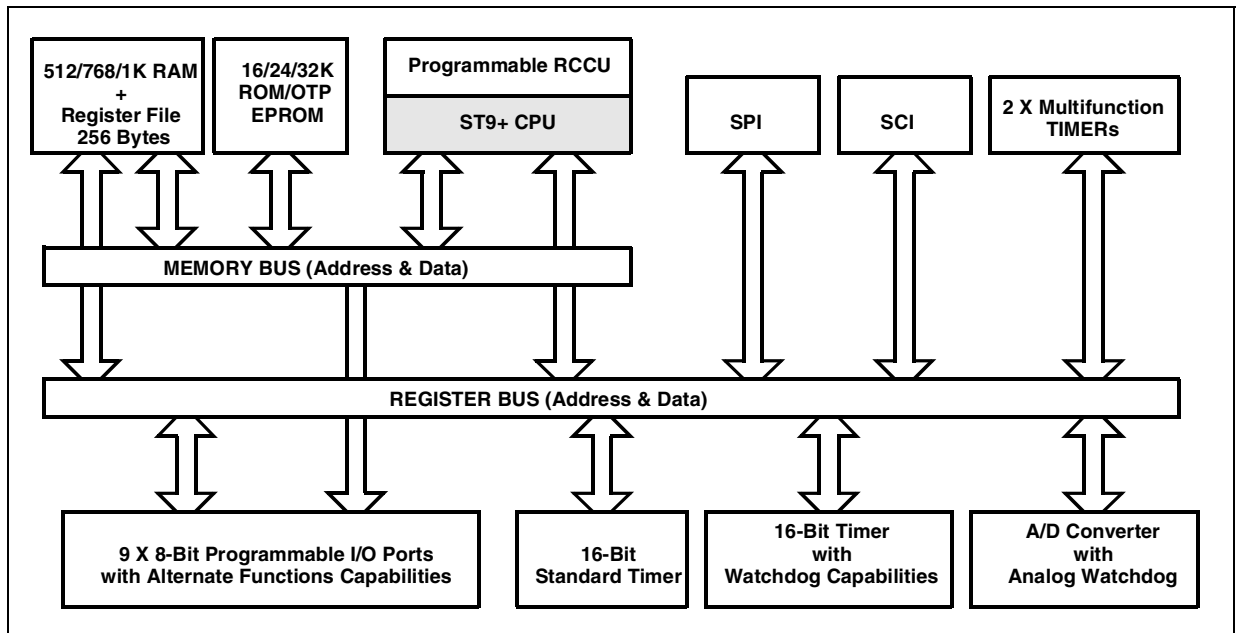



## 2.2.3 ST92F120

Figure 3. ST92F120 Block Diagram

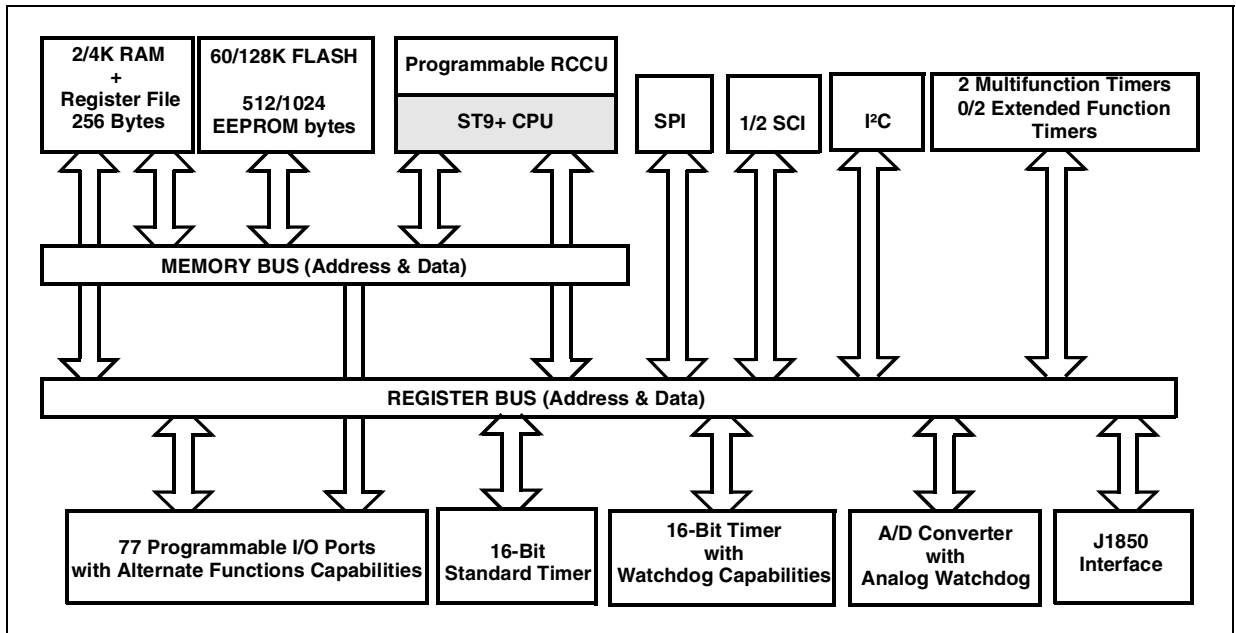

## **3 PROCESSOR CORE: MAIN CONCEPTS**

The term ST9+ designates a family of components. Each component shares the same core, surrounded by a particular configuration of memory and peripherals that make up the specific variant. The ST9+ core has a unique and powerful structure. This chapter explains the main building blocks that you need to get familiar with to be able to make full use of its capabilities.

The main features of the core architecture are:

- Register-Oriented Programming Model
- Single-Space memory addressing
- System and User Stacks
- Interrupt system with fully integrated controller
- Built-in DMA mechanism
- Reset and Clock Control Unit (RCCU) with PLL

### **3.1 ADDRESS SPACES**

The ST9+ provides two different address spaces: Register Space and Memory Space. The Register Space draws its power from its size: 256 registers of which 224 are uncommitted, and from the fact that it can hold data or pointers to data that reside in any of the two spaces. The Memory spaces can address up to 4 Mbytes. This address space is arranged as 64 segments of 64 Kbytes to address Programs and as 256 segments of 16 Kbytes to address Data when the DMA is not used.

#### **3.1.1 Register-Oriented Programming Model**

The usual microprocessor core structure is based on an accumulator. The accumulator is the one register that holds the data to work on and the results of the arithmetic or logical operations applied to it. This structure has become a classic - for its simplicity - the internal data paths of the microprocessor all converge to the accumulator. The instruction set is simple, since you need to specify only one memory address in a data move instruction, the other being implicit: the accumulator itself.

This simplicity has its own drawbacks: the accumulator is the computation bottleneck, since to move data from one place in memory to another place, you have to do it through the accumulator. The simplest transfer involves at least two instructions: one to get the data, the other one to store it.

Register-Oriented models, in contrast, allow you to move data directly from one place to another in a single instruction. Data can come from a register or from a memory address and can go to either to a register or a memory address. You can code the addresses in the instruction, or store them in registers referenced by the instruction. This allows you to optimize your code

by choosing to store frequently used data in registers, leaving less frequently used data in memory.

### 3.1.2 Register File

The ST9+ has a special addressing space for registers, providing 256 different register addresses. This large amount of registers gives you considerable flexibility in allocating variables. Register addresses are coded using one byte. You can use any of these registers to hold data or as a pointer either to other registers or to bytes in memory<sup>(1)</sup>. Contrast this with processors that feature a certain number of registers, but in which some of these registers are meant to be only pointers or indexes, and some others not. These processors only allow transfers between memory and registers. The register organization of the ST9+ gives you a real advantage you can make use of.

### 3.1.3 Direct access to the Register File

The entire Register File can be accessed directly by its address prefixed by an "R" except for register group D (13) that can only be addressed through the Working Register mechanism.

For example to address the register at the address 73, address it as R73, R49h or R1001001b in decimal, hexadecimal or binary. For a double register (16 bits) you can use the "RR" prefix to address any data with an even address.

Any register can be given a user-defined name.

In C language:

```
#pragma register_file data1
char data1;
#pragma register_file data2 60
int data2;
```

and accessed with:

```
data1=13;
data2=0x1234;
```

data1 is automatically allocated in the register file by the linker as no register number is provided. data2 is manually allocated in register RR60. This pragma should be repeated in each file where the variable is made visible through an external declaration.

However using these registers needs an additional byte with the instruction mnemonic. Using Working Registers is more efficient, because it avoids using this address byte.

(1) Except for group E (14) reserved for the system registers and group F (15) reserved for the peripherals.

### 3.1.4 Working Registers

To further improve coding efficiency, a special mechanism has been created: the concept of working registers. This reduces to just 16 bytes the register space accessible by the instructions in the so-called working register addressing mode. Only four bits are required to address this space, allowing both the source and the destination of a data move to be coded in a single byte, thus saving both code size and execution time.

256 registers, when split into groups of 16, give 16 groups. The group used is indicated in a special register, called the **Working Register Pointer**. The register address is made up of the group number and the register address within the group, as follows:

**Figure 4. Register Group Addressing Scheme**

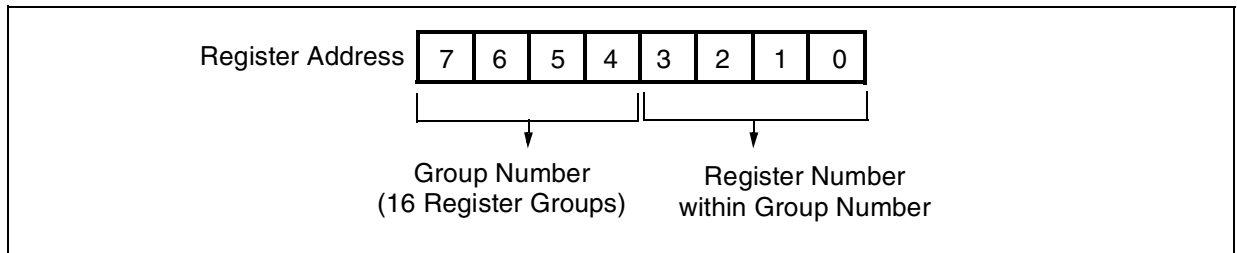

### 3.1.5 Peripheral Register Pages

All internal peripherals are mapped into the register space. Most of them have a multitude of features and can be configured in different ways. This implies that they have a large number of registers. Since only the last group of 16 registers is allocated for peripherals, a special scheme must be used to overcome this problem. It is called paging. The last group of registers actually addresses one pack of sixteen registers that belongs to the peripheral itself. Which pack of which peripheral depends on the value of a register called the **Page Pointer Register**. There can be as many as 64 different pages, providing plenty of space for accessing peripherals.

Here are more details on these two mechanisms.

### 3.1.6 Working Registers and Register Pointers

The working registers offer a workspace of 16 bytes. This is sufficient for most applications, and much more convenient than a single accumulator. However, in some applications, this is still not enough. In this case you can easily allocate more than one register group to a particular program module. Since any register can be accessed directly, it is up to you to decide whether you want to switch working register groups or not to access the other groups of registers.

Since changing the current group involves only one instruction, the concept of working registers can greatly reduce context switching time, for example in the case of an interrupt service

routine. Doing this preserves the contents of the whole group, and the reverse operation restores them, as in the example:

```
; The main program uses the working register group 0
InterruptRoutine:
    pushw   RPP           ; Keep track of current group
    srp     #2           ; Switch to group 1 (see text below for details)
    ...
    ...                 ; Body of the interrupt service routine
    ...
    popw    RPP          ; Restore whatever group was active
    ired    ; Return from interrupt
```

Supposing we could not switch working registers, we would have to push 16 bytes to the stack to ensure that the contents of the working area have been preserved, and pop them back before returning. Obviously the example above is more efficient, both in code and data memory size, and also in execution time.

You use register pointers to allocate the working registers in a particular group. When writing in C or assembly language, you must position the working registers before you use them<sup>(2)</sup>.

Switching groups involves the RPP register pair, made of the two registers RP0 and RP1. These registers are directly accessible, but since their bits are laid out in a non-trivial manner, it is recommended that you set them using only one of the `srp`, `srp0` or `srp1` instructions.

The registers are considered as sixteen groups of sixteen registers each. This is the way they are represented in the register number summary table (See Table 1.). Use the numbers in this table to refer to a register directly, e.g. when writing R35, this designates the fourth register of group 2.

### 3.1.6.1 Switching the 16 Groups of Working Registers

This is done using the `srp` instruction. In spite of what we have explained up until now, and how it is usually represented, the core does not actually divide the registers in 16 groups of 16 registers, but 32 blocks of 8 registers. This is why the `srp` instructions require arguments ranging from 0 to 31 instead of 0 to 15. Here is how the Register Pointers select the desired register group among 16 such groups.

<sup>(2)</sup> Device Datasheet; Address spaces of the register file § 2.2.1 and following, system registers § 2.3.

Figure 5. Selecting a 16-Register Working Group

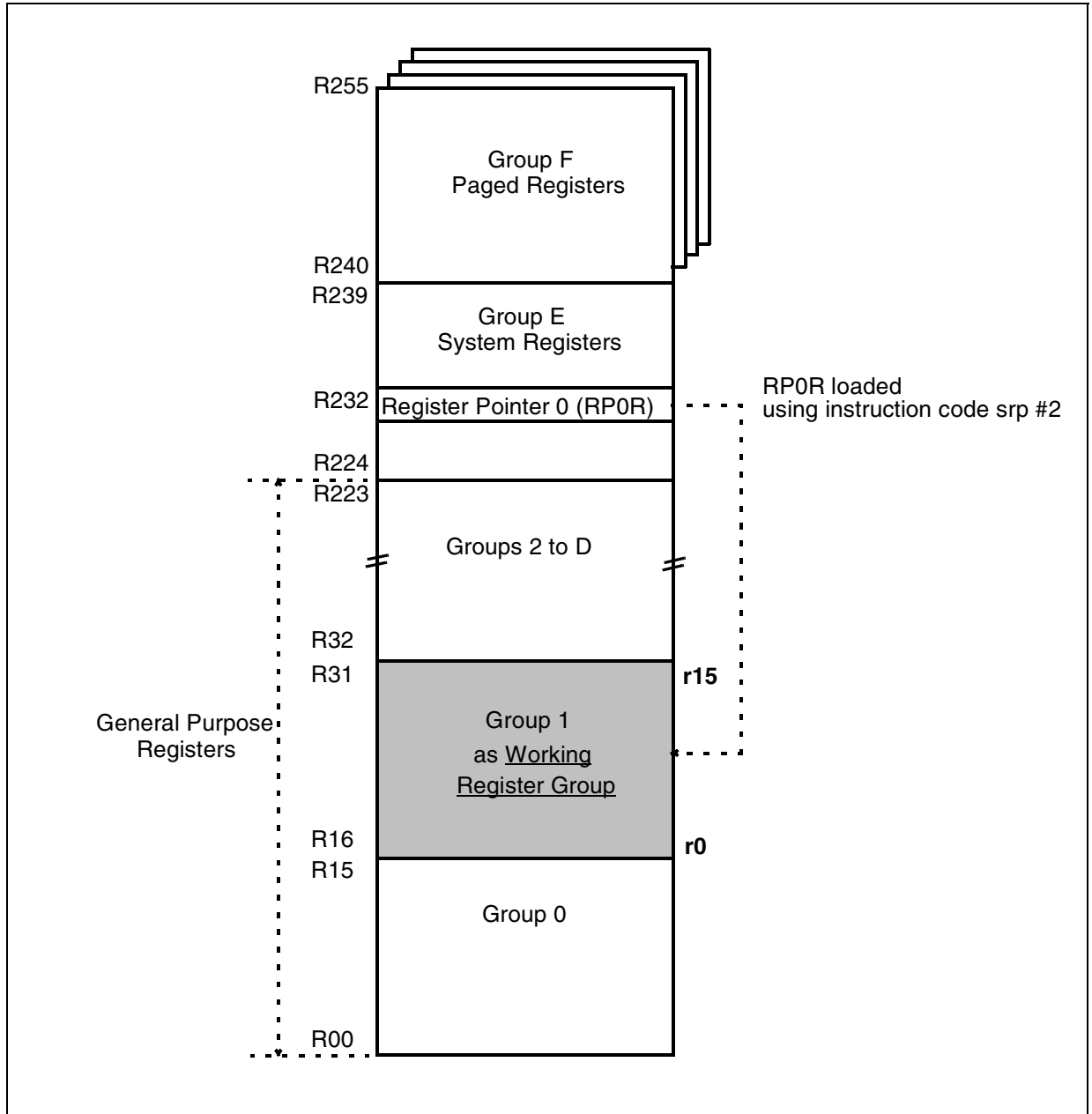

Using `srp` defines one group of sixteen working registers named `r0` to `r15`, and occupying 16 contiguous registers in the register file. The lower case `r` for the register number indicates that it is a working register number, in contrast to upper case `R` registers that indicate an absolute register number. For example, accessing `r3` is the same as accessing `R19` if the current group is group 1:

```
srp #2 ; Switch to group 1
inc r3 ; increment 4th register of the group
```

```
inc R19 ; increment the same register again
```

The following table summarizes the use of the `srp` instruction and its effect in terms of group selection.

**Table 1. Register Page Number Summary**

Hexadecimal register number	Decimal register number	Function	Register group decimal (hexadecimal)	srp #n instruction to select a group to provide r0-r15
F0-FF	240-255	Paged registers	15 (F)	srp #30
E0-EF	224-239	System registers	14 (E)	srp #28
D0-DF	208-223	General purpose registers	13 (D)	srp #26
C0-CF	192-207		12 (C)	srp #24
B0-BF	176-191		11 (B)	srp #22
A0-AF	160-175		10 (A)	srp #20
90-9F	144-159		9	srp #18
80-8F	128-143		8	srp #16
70-7F	112-127		7	srp #14
60-6F	96-111		6	srp #12
50-5F	80-95		5	srp #10
40-4F	64-79		4	srp #8
30-3F	48-63		3	srp #6
20-2F	32-47		2	srp #4
10-1F	16-31		1	srp #2
00-0F	00-15		0	srp #0

**Notes:** Though it is possible, it normally makes no sense to set the working register group either to group E (14) or F (15), since the registers in these groups have pre-defined meanings. You cannot use them to store intermediate values of calculations without greatly affecting the behavior of the microcontroller in an unpredictable way. However, bit-level instructions are only available using working register addressing, so when you need to do bit manipulations in these groups, setting the register pointer to either 28 or 30 is an efficient way of programming when accessing these two groups.

The `srp` instruction is the only one you have to use to switch register groups, and is the way working registers are used in most programs. However, the working register scheme includes a subtlety that is seldom used, but that could give you even more flexibility in some cases. This is what is described in the next paragraph.

The same register group number can be selected by an odd or even number. In fact, the formula is:

```
srp    2*n+1    ; for group n
```

or

```
srp    2*n     ; for group n
```

### 3.1.6.2 Defining Two Separate Groups of Eight Working Registers

In this mode, the `srp` instruction is not used. Instead, we use the pair of instructions `srp0` and `srp1`. When using a working register, `r0` to `r7` address the first to the eighth register of the whole group selected by half the value in `RP0` i.e. all the registers of the half group selected by `RP0`. Registers `r8` to `r15` relate to the first to the eighth register of the group pointed to by `RP1`. Here is how the two blocks are selected:

Figure 6. Register Numbers

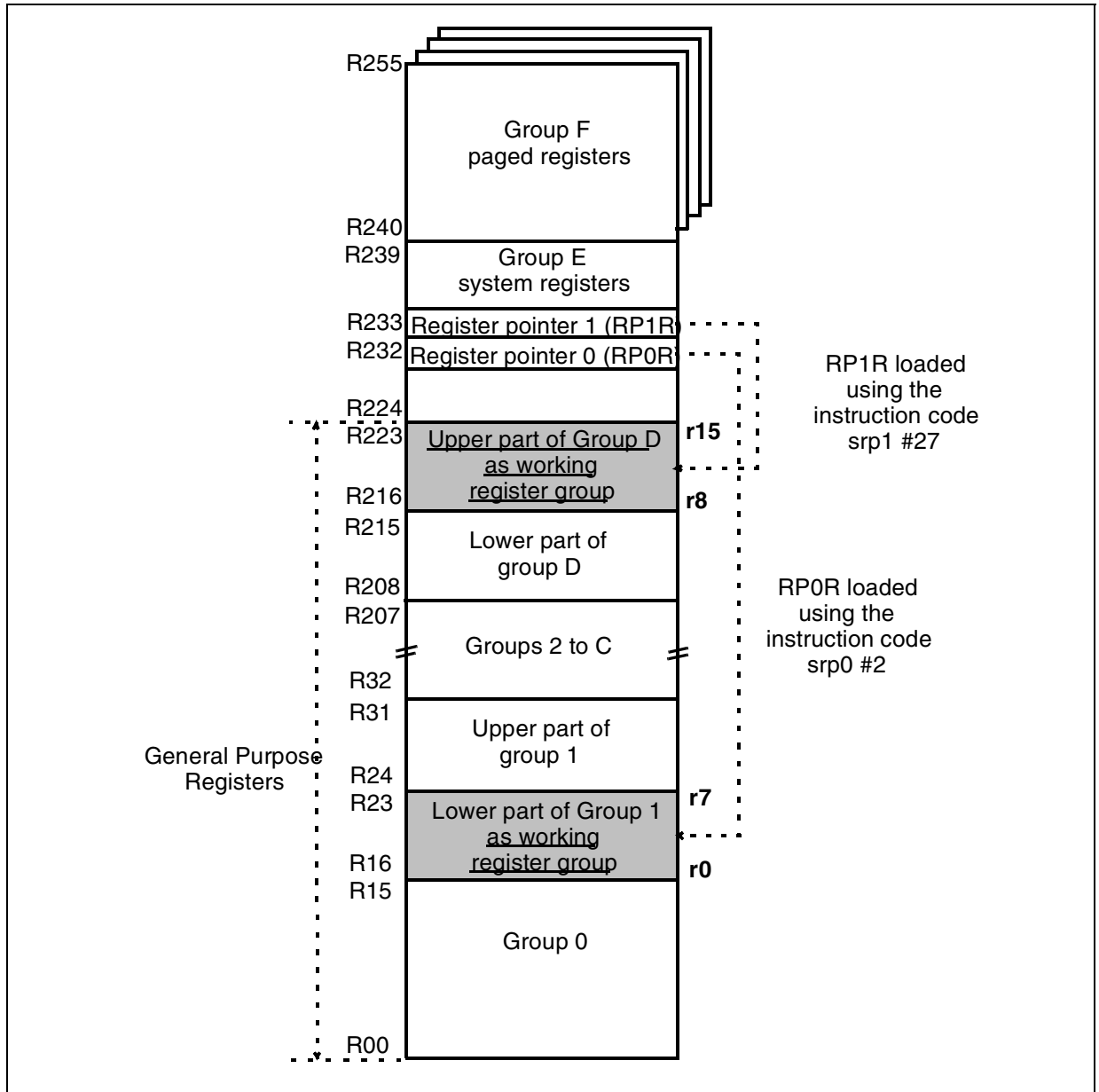



As an example, if RP0 is set to half group 2 (lower part of whole group 1) and RP1 to half group 27 (upper part of whole group 13), r0 will designate R16 ( $2 \times 8 + 0$ ) while r15 designates R23 ( $27 \times 8 + 7$ ).

Using either method depends on the organization of the data in the register file. You may find it convenient to use two 8-register blocks if you need to make quick calculations on pairs of data that are far apart in the register file.

The page numbering and switching instructions are summarized below:

**Table 2. Register Page Number Summary**

Hexa-decimal register number	Decimal register number	Function	Eight-Register block decimal (hexadecimal)	srp0 #n (or srp1) #n instructions to select a block to provide r0-r7 and r8-r15 respectively
F8-FF	248-255	Paged registers	31 (1F)	srp0 or srp1 #31
F0-F7	240-247	Paged registers	30 (1E)	srp0 or srp1 #30
E8-EF	232-239	System registers	29 (1D)	srp0 or srp1 #29
E0-E7	224-231	System registers	28 (1C)	srp0 or srp1 #28
D8-DF	216-223	General purpose registers	27 (1B)	srp0 or srp1 #27
D0-D7	208-215		26 (1A)	srp0 or srp1 #26
C8-CF	200-207		25 (19)	srp0 or srp1 #25
...	...		...	...
78-7F	120-127		15 (0F)	srp0 or srp1 #15
...	...		...	...
20-27	32-39		4	srp0 or srp1 #4
18-1F	24-31		3	srp0 or srp1 #3
10-17	16-23		2	srp0 or srp1 #2
08-0F	08-15		1	srp0 or srp1 #1
00-07	00-07	0	srp0 or srp1 #0	

When you use an 8- or 16-register group, you may very likely have a subroutine or an interrupt routine that uses a different set of working registers. You must save (push) the pair of register pointers RPP that include RP0 and RP1 at the beginning of the routine and restore them on exit.

### 3.1.6.3 Peripheral Register Paging

Group F of the 16-register groups is paged so that as many as 64 different groups can be mapped to this address range. This large space is used to accommodate the registers related to the peripherals. The paging technique allows you to add any number of peripherals and still be able to handle them without using up more addresses in the register space.

When you access a register in group 15, first set the Page Pointer Register to the number of the page that contains the register you want. Here is how a page is selected:

Figure 7. Selecting Page Registers

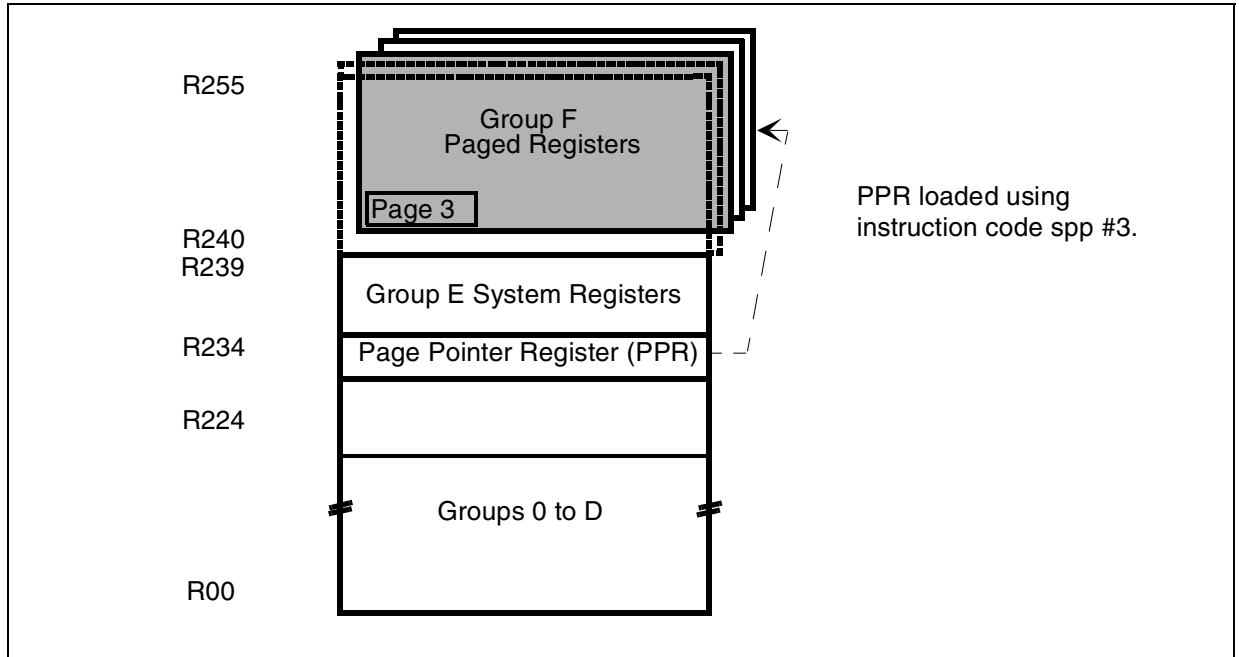

As with the working registers, if a subroutine or an interrupt routine needs to access a peripheral that uses paged registers (which is very likely), you must save (or push) the register pointer PPR at the beginning of the routine and restore it on exit.

**Notes:** In both assembly and C languages, include files are supplied with symbolic names pre-defined for all the peripherals. These names are unique for each peripheral; however several different names relate to the same register, but in a different page. You must bear in mind that writing for example (in C language):

```
S_ISR = 0; /* clear serial peripheral error register */
```

does not automatically select the proper page; this statement must be preceded by another one that selects the SCI page. Since no predefined C statement exists for this, a convenient way is to define an assembler statement under the form of a macro that will read nicely in the C source.

An example of the correct way to access the SCI register is:

```
#define SelectPage(Page) asm ("spp %0":: "i" (Page)) ; /* pseudo function
to select a page */
SelectPage( SCI1_PG ); /* Select the serial peripheral page */
S_ISR = 0 ; /* Clear serial peripheral error register */
```

### 3.1.7 Memory Management Unit

Like most microcontrollers, the ST9+ has a bus for interfacing internal and external memories. This allows you to store both programs and data. A special feature of the ST9+ is that it can address a 4 Mbyte single space to address ROM, RAM, EPROM, EEPROM, FLASH.

To address the 4 Mbytes of memory, the address bus is 22 bits wide. To manage the 22-bit address with 16-bit direct or indirect addressing, the memory mechanism adds extra bits to the 16-bit address and then works with segments (see Figure 8) or pages (see Figure 11). The memories are arranged in 64 segments of 64 Kbytes for the program and in 256 segments of 16 Kbytes for data.

A set of special registers is used to extend the 16-bit address. Programs use the CSR, DMA uses the DMASR or ISR and interrupts use the ISR or CSR register to provide the 6 Most Significant Bits to make a 22-bit address. Data uses a set of four registers (DPR0-3) to provide the 8 Most Significant Bits to make a 14-bit address.

Data can be addressed in the Program segment by using special move instructions: `lddp`, `ldpp`, `ldpd`, `lddd`.

It is easier from a hardware point of view to use only one address space for Program and Data.

**Figure 8. Addressing via CSR, ISR and DMASR**

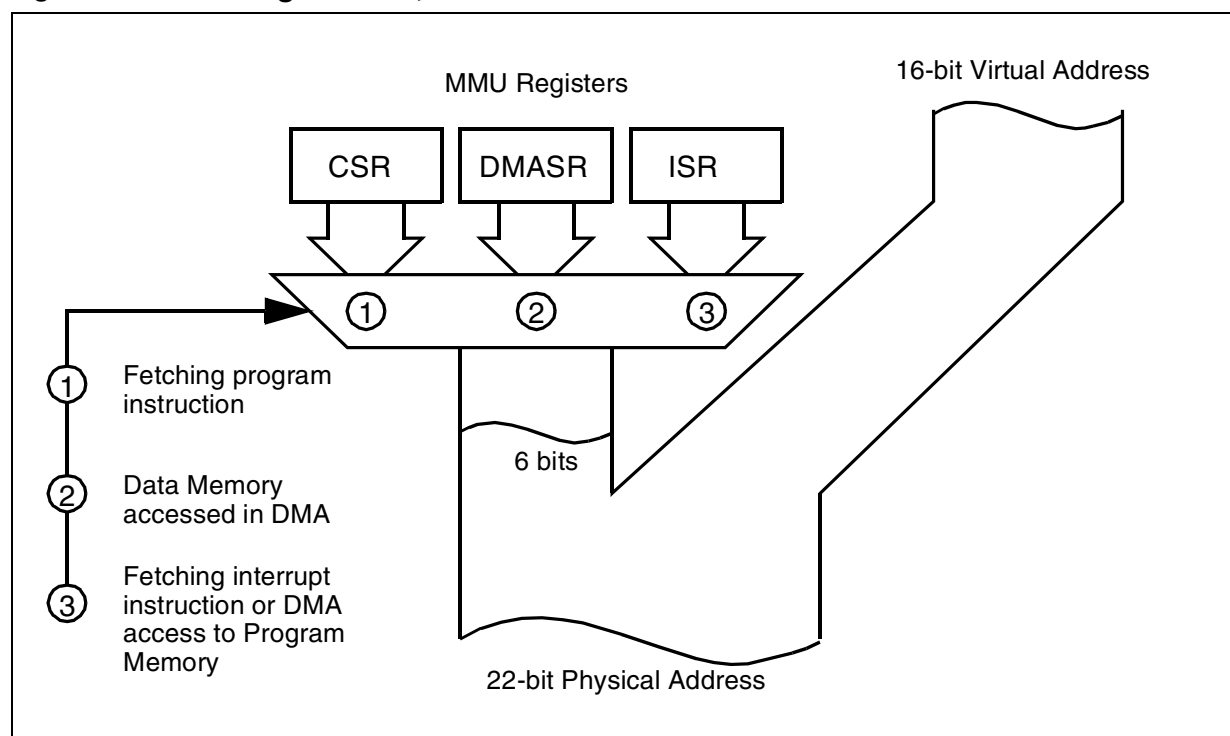

### 3.1.7.1 Program Segment

We can consider this memory as linear since we can jump anywhere in memory space using the special JPS, CALLS and RETS instructions.

The 6-bit CSR register is used to extend the 16-bit address to a 22-bit address by concatenation (see Figure 8). To make a fast branch in the same segment, use the common JP, CALL and RET instructions.

To branch to another segment using a far call, the use of CALLS saves the current PC value and the CSR value (Code Segment Register) in the stack, before loading the PC and the CSR registers with the new values. Every time the segment changes you have to use the far branch even if you branch from address (n)FFFFh to (n+1)0000h. This is because the program doesn't manage the 6 high-order bits of the 22-bit program addresses if you don't use a far branch to change the CSR register value. The script file (described in the Development Tools chapter) allows you to place all your program modules anywhere in a single segment.

The far branch instruction adds only 2 to 4 additional cycles compared to a near branch instruction.

**Note:** In C language, using the small code model (this means only one 64 Kbyte segment is used), all calls use local branches. If more than one segment is used, the large code model is required and all calls use far branches even when branching locally. To avoid far calls in the same segment, the segment to be called has to be declared as **static** if it is not called from another segment.

### 3.1.7.1.1 Segment and Offset in Assembler Mode or C Language

The Offset represents the address in the segment with 16 bits. If the Segment and the Offset are known, the following syntax is used for the far branches:

```
jps      segment,offset      ; 6 bits + 16 bits
jps      symbol              ; 22 bits
calls    segment,offset      ; 6 bits + 16 bits
calls    symbol              ; 22 bits
calls    (R), (rr)           ; 6 bits + 16 bits
calls    (r), (rr)           ; 6 bits + 16 bits
rets                                          ; 22 bits
```

The assembly tools accept a set of directives which retrieves the elements of a function address or of a label.

The operator **SEG** (stands for SEGment) allows you to extract the segment number of a label; similarly, the operator **SOF** (stands for Segment OFFset) allows you to extract the offset of a label within its segment.

These operators are especially useful when applied to a function or instruction label, although the macro-assembler and assembler do not verify the type of the label.

Example:

```
ld      r0, #SEG Function      ; extract the 6-bit segment
```

```
ldw      rr2, #SOF Function      ; extract the 16-bit offset
calls    (r0), (rr2)
```

The same functions exist in C language: SEG(Function); SOF(Function).

### 3.1.7.2 Interrupt Service Routine Segment

One program segment is reserved for storing the Interrupt Service Routines. All the interrupt routines start in this segment.

To obtain a 22-bit address, the 16-bit address is concatenated with 6 bits from the ISR register (the 6 bits from the ISR register are the high-order bits of the address).

To offer compatibility with the previous ST9 versions and to have a new powerful address mechanism, you can select "ST9old" or "ST9+" mode using the EMR2 bit in the ENCSR register.

Both modes use the concatenation of the ISR register value and the 16-bit address as shown in Figure 8 to address the interrupt vector.

Then, in "ST9old" mode, only the ISR register value is used during the interrupt routine. So it's not possible to jump to another segment from the Interrupt Service Routine because the CSR register value is not saved with the FLAGR value and the current PC value when the interrupt occurs. The advantage of "ST9old" mode is to reduce stack memory usage and CPU cycles by not saving the CSR value (see Figure 9). This figure shows you the different mechanisms that are used when an interrupt occurs, when a branch or a call is executed during the interrupt routine and when the return from interrupt instruction (RETI) is executed.

Figure 9. Interrupt Processing in "ST9old" Mode

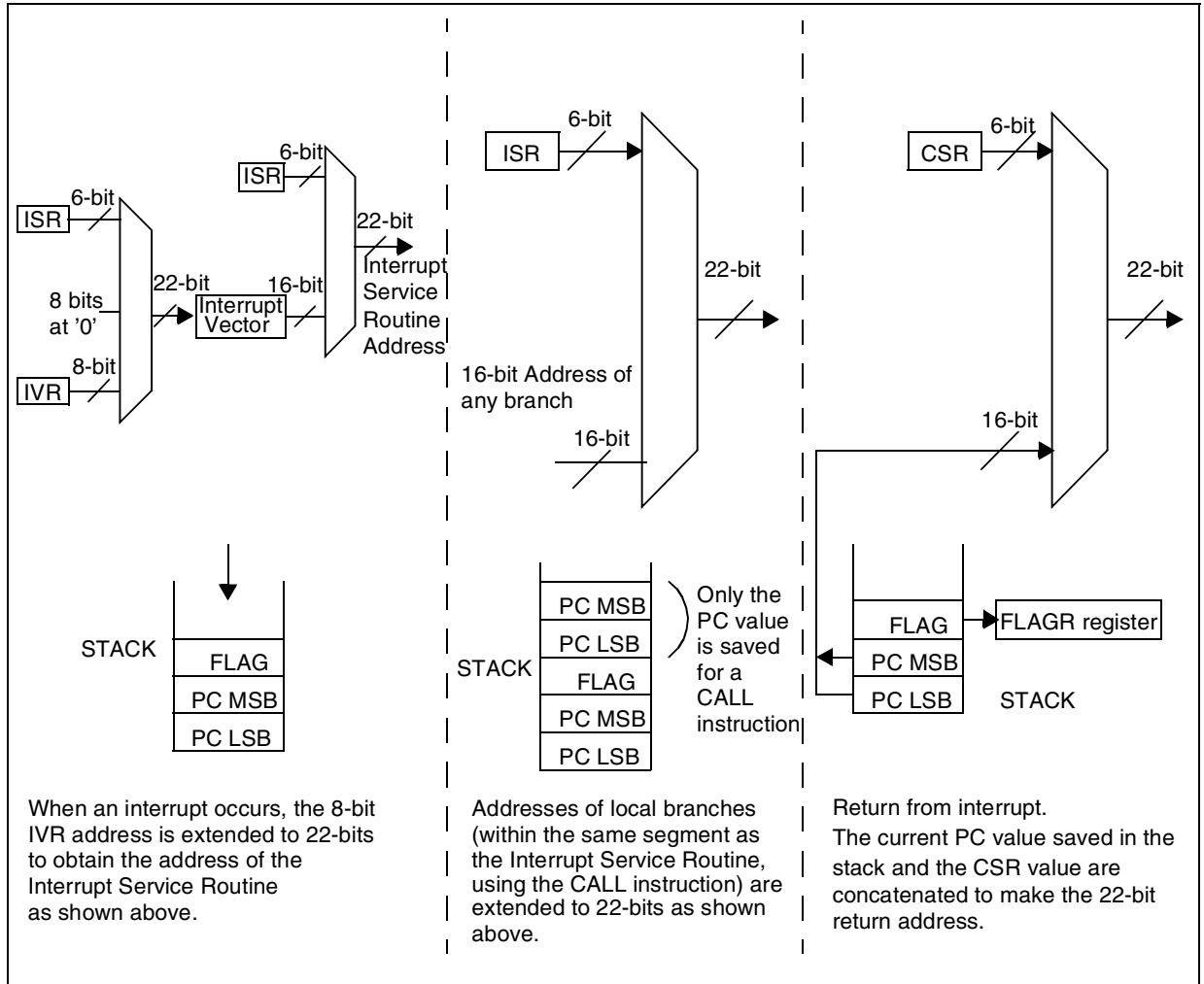

In "ST9+" mode, saving the CSR value allows you to change its value to branch to another segment. When the interrupt occurs and when the current PC, CSR and FLAGR values are saved, the ISR register value is stored in the CSR register (see Figure 10).

Figure 10. Interrupt Processing in "ST9+" Mode

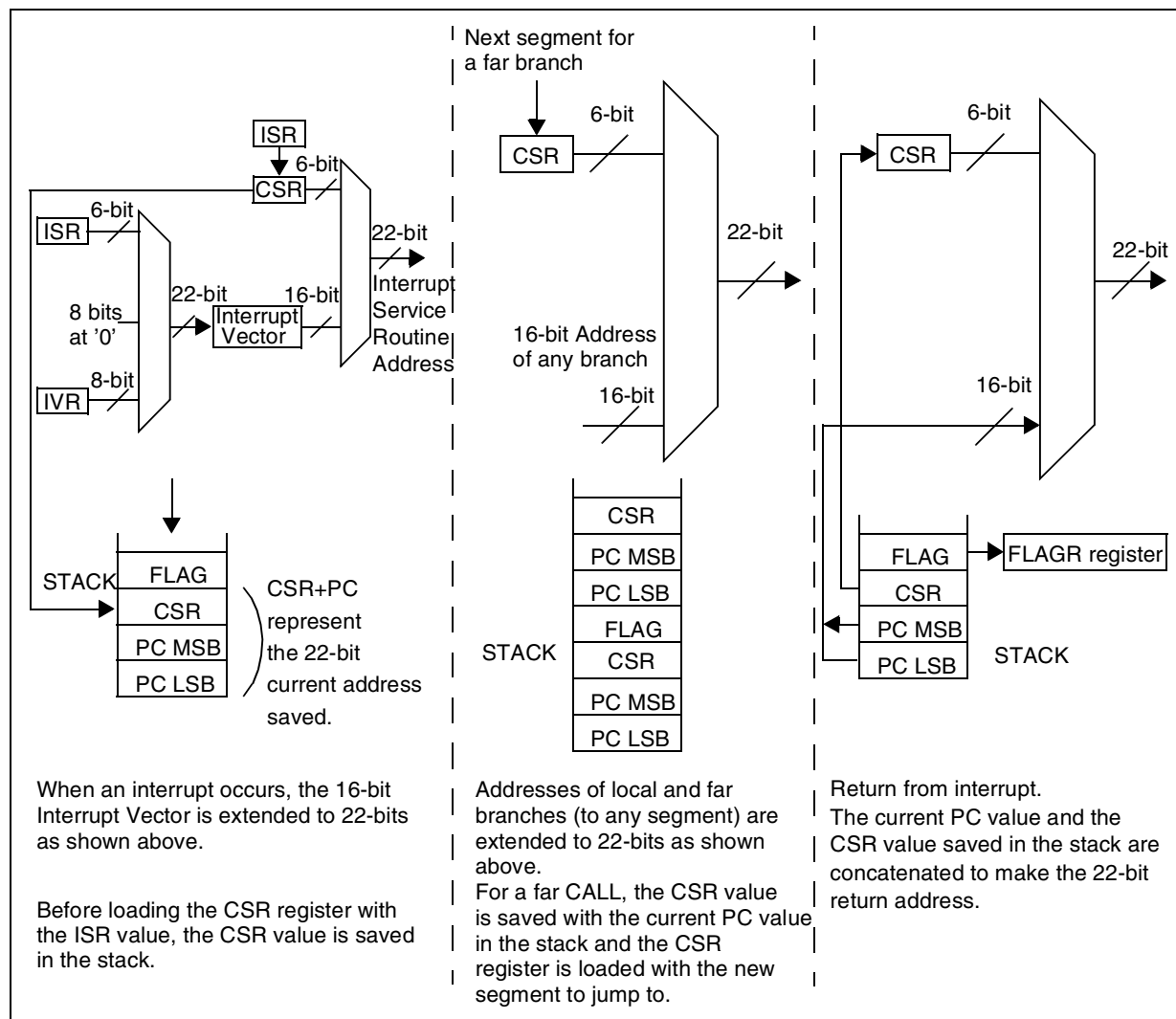

### 3.1.7.3 DMA Segment

To address the total 4 Mbytes of memory in a DMA transaction, the DMASR points to a 64-Kbyte segment. Since there is no need to have more than one segment at the same time for the transaction, the DMA uses a single 64-Kbyte segment instead of 4 pages like a Data Segment (see below). To use the DMASR register, the DP bit in the DMA Address Register (DAPR) must be set. If DP is reset, the DMA uses the ISR register instead of the DMASR register.

### 3.1.7.4 Data Segment

Data uses the page mechanism to address the 4 Mbytes of memory.

To authorize data coming from different 64-Kbyte segments, a set of 4 Data Page Registers (DPR0 to DPR3) allows you to address 16 Kbytes per register (see Figure 11). The DPR is selected with the 2 high-order bits of the 16-bit data address:

DPR0: from 0000h to 3FFFh (b15-b14=00)

DPR1: from 4000h to 7FFFh (b15-b14=01)

DPR2: from 8000h to BFFFh (b15-b14=10)

DPR3: from C000h to FFFFh (b15-b14=11)

After you select the DPR, the 8-bit value of the selected DPR register is used to extend the 14 remaining bits of the address to 22 bits.

For example, if DPR0 equals 20h and DPR1 equals 2h, each memory access in the range of 0000h to 3FFFh uses the DPR0 page and addresses data from 080000h to 083FFFh, and each memory access in the range of 4000h to 7FFFh uses the DPR1 page and addresses data from 008000h to 00BFFFh (see Figure 11). For example:

16-bit address = 0010 0101 1010 0101 = 25A5h      0000h < 25A5h < 3FFFh

DPR0 is selected, so the 6 high-order bits are equal to 20h

22-bit address = 0010 0000 10 0101 1010 0101

DPR0 value, 14 LSB of the 16-bit address

= 00 1000 0010 0101 1010 0101 = 0825A5h

With this mechanism, if the 16-bit addresses are different only on the 2 highest bits and if all the DPR registers selected with these two bits have the same value, the resulting 22-bit address will be the same.

Four pages of 16Kbyte of data memory are enough for many applications and allow you to use data from different segments without costing additional CPU cycles. With four DPRs, you can access up to 64K (4 x 16K) of data without changing the DPR values. Data can be variables stored in RAM or constants stored in program ROM.

The four DPR registers are located in the MMU register page (page 21 of register group F). If you use them frequently, you can relocate them to register group E, by programming bit 5 of the EMR2 register (R246 in page 21). This prevents you from having to switch to the MMU register page from another peripheral register page in order to change a DPR register value.



Figure 11. Addressing via DPR0-3

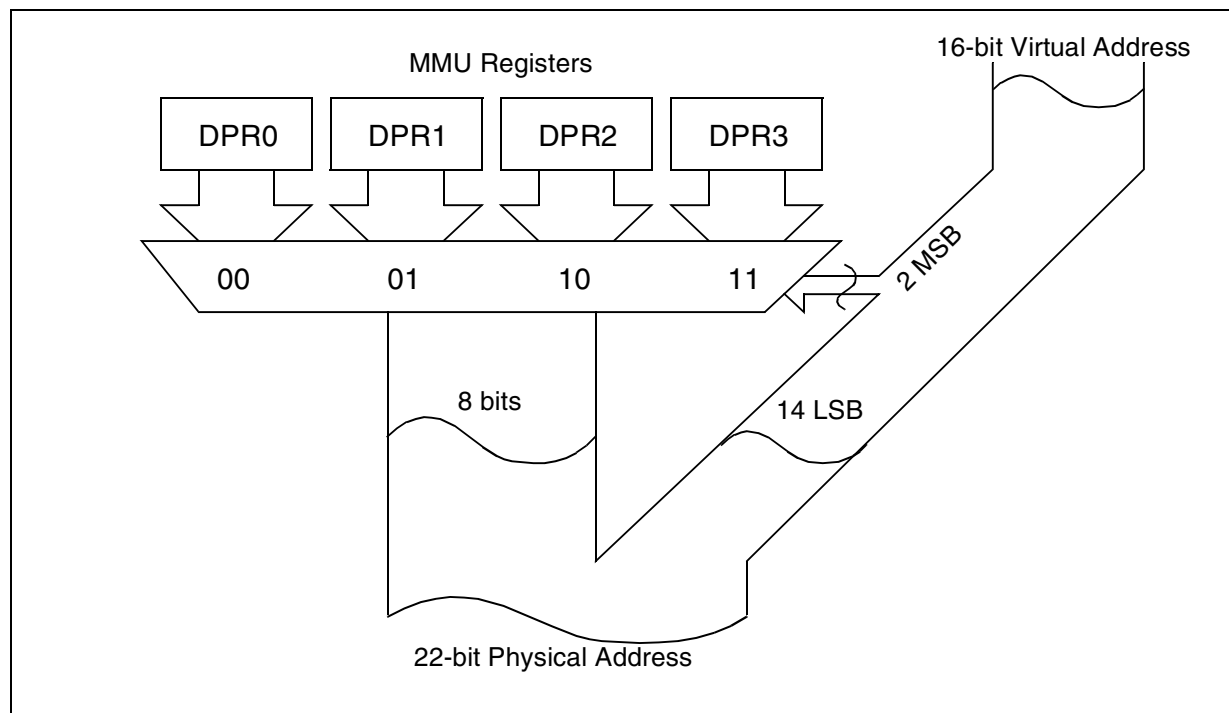

### 3.1.7.4.1 Accessing the Page and the Offset in Assembler or C Language

The assembly tools implement a set of operands which allows you to extract the components of a data address.

The **PAG** operator (stands for PAGE) extracts the page number of an address; similarly, the **POF** operator (stands for Page Offset) extracts the offset of the address within the page.

Syntax:

PAG label

POF label

Be careful that directly using the data label and using the POF operator on a data label are not equivalent: the data label gives the 16 bits of the logical label address; the POF operand gives the 14 lowest bits of the label's physical or logical address.

Example:

Assuming data is mapped at address 0x129876:

```
ldw    rr2, #POF data    ; rr2 = 0x1876
ldw    rr4, #data        ; rr4 = 0xD876 (with DPR3=0x4A)
```

Remember that you must take care of which data pointer has to be set before accessing a variable.

Example:

Assuming that data has been mapped in a page aligned on address 0xC000, this means that DPR3 will be used, therefore the following code is correct:

```
ld      DPR3, #PAG data
ldw     rr2, data
ld      r4, (rr2)
```

In assembly language, it is possible to access data through another DPR:

Example:

Still using data at an address aligned with 0xC000, following code is correct:

```
ld      DPR2, #PAG data          ; if data address=0x01C765, DPR2=7
ldw     rr2, #(POF data)+0x8000; rr2=0x8765
                                   ; #(POF data) to reset bit 15 and 14
                                   ; and 0x8000 to use DPR2
ld      r4, (rr2)                ; indirect addressing mode
...
ld      r4, (POF data)+0x8000 ; direct addressing mode
```

It is important to look at the explicit usage of the immediate addressing mode (#) to get the page number and the offset; it is consistent with the ST9 assembly syntax shown in the following example:

```
ldw     rr2, #Var
ld      r4, (rr2)
...
ld      r4, Var
```

The same functions exist in C language: PAG(data); POF(data);

### **3.2 STACK MODES**

The ST9+ allows you to have two separate stacks: a system stack and a user stack. The core uses the system stack in interrupt routines and subroutines to save return addresses, the flag register and the CSR depending on option (EMR2 register bit Enable Code Segment Register). You can also use it under program control to save data, using the `push` and `pop` instructions.

The user stack works exactly the same way, using the `pushu` and `popu` instructions but only under program control, which means that the user stack is not changed by the system. You may choose to use a separate space for your data, or to store them in the same stack as the return addresses.

Both stacks can independently be located either in RAM or in the register file. You select this using the SSP and USP bits in the MODER register (R235) for the system stack and the user stack, respectively. A low bit value selects a RAM stack, and a high bit value selects a Register File stack.

Since the stacks grow towards low addresses, the stack pointers must be initialized to the highest location plus one<sup>(3)</sup> of the space reserved to it. This location becomes the "bottom" of the stack. When the stack is located in the register file, take care that it does not overwrite other data, in particular the registers located in groups 14 (0EH) and 15 (0FH). For this reason it is advisable to set the system stack pointer to the end of group 13 (0DH).

The last register of this group being R223, the instruction that sets the stack pointer will be:

```
ld      sspr, #224 ; set stack pointer to one above end of group 13
```

**Note 1:** Using two separate stacks in the same kind of storage (memory or register) area is likely to consume more space than if a single stack is used. So most of the time, only one stack will hold both return addresses and arguments for functions. You can then use `pushu` and `popu` instructions to manipulate data with the convenience of auto incrementing or decrementing the pointer after each access.

As an example, refer to the C language start-up files which initialize both the user and system stacks.

The following diagram illustrates the two options for locating the stack: in the register file or in memory.

<sup>(3)</sup> The push instruction decrements the stack pointer before writing the data, so this location would never be used if set to the top location.



Most instructions of the ST9+ exist in both byte and word forms. That is, they can operate on either 8 (byte) or 16-bits (word). The mnemonics of the word-instructions all end with a "w", as in the following examples:

Load	Add	Subtract	Logical and	Logical or	Compare	Push	Pop
ld	add	sub	and	or	cp	push	pop
ldw	addw	subw	andw	orw	cpw	pushw	popw

The new powerful instructions added to the ST9old are the CALLS, RETS, JPS instructions for far branching to change the program segment and the instructions used for C language applications, LINK, LINKU, UNLINK and UNLINKU. Moreover, all instructions have been optimized compared to ST9old.

### 3.3.1.1 Load Instructions

Beside the classical load instructions found on most microprocessors, there are four special load instructions for moving data between two locations in memory.

One instruction to move data from data segment to data segment; `lddd`. This instruction allows you to post-increment the destination and the source index register at the same time. The `ld` instruction needs two instructions to do this. An example for moving a block of data would be:

```
ld      rr0, #Source
ld      rr2, #Destination      ; initialisation of the pointers
ld      r5, #Num_loop         ; number of elements to move
loop:
ld      r4, (rr0)+            ; transfer of one byte
ld      (rr2)+, r4
djnz   r5, loop
```

The two `ld` instructions are coded using 6 bytes and executed in 24 cycles.

The same program with the `lddd` instruction:

```
ld      rr0, #Source
ld      rr2, #Destination      ; initialisation of the pointers
ld      r5, #Num_loop         ; number of elements to move
loop:
lddd   (rr2)+, (rr0)+        ; transfer of one byte
djnz   r5, loop
```

The `lddd` instruction is coded using 2 bytes and executed in 14 cycles.

Here are the four possible data transfers:

<b>Instruction</b>	<b>Moves data from...</b>	<b>...to</b>
<code>lddd</code>	data segment (uses the DPR0-DPR3 registers)	data segment
<code>ldpp</code>	program segment (uses the CSR register)	program segment
<code>lddp</code>	program segment	data segment
<code>ldpd</code>	data segment	program segment

These four instructions improve the performance of data block moves (frequently used in C programs).

As you can see in the table above, the data move can be between data and program segments. Here's an example of a data move from a Data segment using the DPR register to a Program segment using the CSR register:

```

ld      rr0, #Source
ld      rr2, #Destination      ; initialisation of the pointers
ld      r5, #Num_loop         ; number of elements to move
loop:
ldpd    (rr2)+, (rr0)+        ; transfer of one byte
djnz    r5, loop
    
```

The data load with `rr0` comes from the data segment selected by one of the four DPR register values depending on the `rr0` value and then are stored in the program segment selected by the CSR register value.

(Please refer to the MMU Section 3.1.7 for an explanation of data and program segments).

**3.3.1.2 Test Under Mask**

These instructions, `tm` and `tmw`, perform a logical (bitwise) AND between the two operands, but do not store the result. They only set the Z and S bits of the flag register for a later conditional jump on zero or sign. The mask is a value in which the bits that are set to 1 select the corresponding bits of the value to be tested for non-zero. As an example, in the following instruction:

```
tm value, mask
```

If the mask is a byte whose binary value is 11000000, only the left-most two bits of the unknown value will be tested, and a later branch if zero will be taken or not according only to these bits. As shown below, the same mask is used for two values that differ only by one bit:

```

0 0 0 1 1 0 1 0 1      Byte to be tested      1 0 1 1 0 1 0 1
1 1 0 0 0 0 0 0 0      Mask used for testing  1 1 0 0 0 0 0 0
    
```

0 0 0 0 0 0 0 0 0 0	Result of the logical AND operation	1 0 0 0 0 0 0 0 0 0
jump taken	Result of the "jump if zero"	jump not taken

Two more instructions, `tcm` and `tcmw`, work essentially the same way, but they take the complement of the value to be tested before ANDing it with the mask, as follows:

`tcm value, mask`

The same two cases will provide the following results:

0 0 0 1 1 0 1 0 1	Byte to be tested	1 0 1 1 0 1 0 1
1 1 1 0 0 1 0 1 0	Complement of the byte to be tested	0 1 0 0 1 0 1 0
1 1 0 0 0 0 0 0 0	Mask used for testing	1 1 0 0 0 0 0 0 0
1 1 0 0 0 0 0 0 0	Result of the logical AND operation	0 1 0 0 0 0 0 0 0
jump not taken	Result of the "jump if zero"	jump not taken

The jump would be taken if the byte to be tested had two 1's in its most significant two bits, for example 11110101.

### 3.3.1.3 Push and Pop

Since there are two stacks, there are two kinds of push and pop instructions. The mnemonics `push`, `pushw`, `pop` and `popw` act on the system stack, which can be either in the register space or in the memory space. The mnemonics `pushu`, `pushuw`, `popu` and `popuw` act on the user stack, that can also be either in the register space or the memory space. The stack pointer used in each case is the `SSPR` or the `USPR` register pair respectively. The stack pointers are always decremented before writing on pushing, and they are incremented after reading on popping. Thus the stack pointer always points to the last byte written. This is worth knowing if you need to manipulate the stack contents.

The operands to be pushed can be a register, a pair of registers or an immediate value:

```
push r6
push (R120)
push #80
pushw RR100
pushw #1500
```

Pushing an immediate value is especially useful when you are programming in C.

A special push instruction is Push Effective Address. This instruction does not push the data itself, but the memory address of the data. For example:

```
pea 5(rr2)
```

This takes the contents of rr2, adds 5 and pushes the result onto the stack. This is widely used in C programming.

### 3.3.1.4 Multiply and Divide

The multiply instruction takes two byte operands and provides a word result. All numbers are treated as unsigned numbers (operands 0 to 255, result 0 to 65535). Though both operands are bytes, the first one must address a word to receive the result. The first operand should then reside in the low byte of the word, and the high byte, not used in the operation, will be overwritten. The flag register is affected but the state of the flags after the operation is meaningless.

To multiply a signed number (operands -128 to 127) by an unsigned number (operands 0 to 255) with a result in the range of -32768 to 32767, refer to the example given below:

```
ld      r1,#signed_data
ld      r4,#unsigned_data
btjt   r1.7,neg
mul     rr0,r4          ; rr0 = r1*r4, with r1 value a positive signed
                          ; number
jp      end
neg:
mul     rr0,r4          ; rr0 = r1*r4, with r1 value a negative signed
                          ; number
sub     r0,r4           ; rr0=rr0-100h*r4
end
```

With the signed operand equal to 226=0E2h (means -30 for signed data) and the second unsigned operand equal to 0Fh (+15) the result will be -450 (0FE3Eh).

This "eight bits signed by eight bits unsigned" multiplication with a "sixteen bits signed" result takes a maximum of 36 cycles.

There are two divide instructions.

The **div** instruction divides a word by a byte, and returns the quotient and the remainder as the low and the high bytes of the destination respectively. For example:

```
ldw     rr0,#31184      ; rr0=#31184
ld      r2,#201         ; r2=#201
```



```
div    rr0,r2          ; rr0=1D9Bh, 1Dh=#29 and 9Bh=#155
```

This puts the value 155 in r1 (the quotient) and the value 29 (the remainder) in r0, and r2 still contains 201.

If the divider is greater than the dividend, nothing is done. If the divisor is zero, a trap is triggered that acts like an interrupt request, and uses the vector at locations 2 and 3 in program memory. It is up to you to write the appropriate code to handle this trap. Finally, the numbers to be divided should be such that the quotient be less than 256, that is, can be stored in a single byte. Otherwise, the results are undefined.

The usable result is only the data stored in r1 which is 155 (for the previous example), the remainder must be divided by the divisor (201) to give more precision (16-bits precision).

```
ldw    rr0,#31184      ; rr0=#31184
ld     r2,#201         ; r2=#201
div    rr0,r2          ; rr0=1D9Bh, 1Dh=#29 the remainder and
                        ; 9Bh=#155 the quotient
ld     r4,r1           ; r4=9Bh=#155
clr    r1              ; rr0=1D00h
div    rr0,r2          ; rr0=0BC24h, 0BCh=#188 the remainder and
                        ; 24h=#36 the quotient
ld     r0,r4           ; rr0=09B24h, 09B24h means in fix-point
                        ; with the point in the 16-bits middle
                        ; 09B24h=155.140625 instead of
                        ; #31184/#201=155.1442786
```

In the best case, the number of cycles required to divide a word by a byte with 16-bits precision is 80 cycles. This program has to manage overflow and divide by zero functions in order to be able to be used.

The **divws** instruction performs one of the sixteen partial divides required to divide a double word by a word, so you need to write a subroutine to perform the division completely. An example subroutine is given in the ST9+ Programming Manual.

### 3.3.1.5 Bit Operations

Microcontrollers are often used for controlling inputs and outputs on a single-bit basis, in order to read the state of a contact, switch a relay on or off, etc. Because of this and because the data is stored in bytes, instructions for bitwise manipulation of data are welcome.

The ST9+ provides instructions to load, and, or, exor, set, clear, complement and test single bits. These are bld, band, bor, bxor, bset, bres, bcpl, btset.

To designate a single bit in a byte, the notation .n is used. For example, r0.3 means bit 3 of r0. Here are examples of bit manipulation instructions:

```
bld      r0.2, r6.4      ; bit 4 of r6 copied to bit 2 of r0
bld      r0.3, !r6.0     ; complement of bit 0 of r6 copied to bit 3 of r0
band     r0.2, r0.3      ; r0.2 contains now (r6.4) and not (r6.0)
bor      r0.2, r2.7
bset     r0.0             ; bit 0 or r0 set to 1
bcpl r0.1; bit 1 of r0 is complemented
```

All the above instructions act on single working registers. If the source operand is preceded by '!', the complement of the source bit is used.

To test a bit, to condition a later jump, we have already described the tm and tcm instructions. There is another instruction, btset, that can act on either a single or a double working register, and that sets the Z bit of the FLAGR register if the designated bit is zero. After which, the bit is set to one. You can use this instruction in an interrupt service routine to test for a request and acknowledge it in a single instruction.

**Warning.** Don't use the bit manipulation instructions directly on bidirectional ports. To avoid unwanted modifications to the port output register contents, use a copy of the port register, then transfer the result with a load instruction to the I/O port. (Refer to the Input/Output Bit Configuration section in the Device Datasheet for more details.)

### 3.3.1.6 Test and Jump

The btjf and btjt instructions test if a bit is set or cleared respectively and branch to another program location if true. For example:

```
btjt     r1.5, Lampon
bset     r1.5             ; switch lamp on
Lampon:
...      ; continuation of the program
```

Two instructions are well-suited for implementing lookup tables. These are cpjfi and cpjti. They compare a byte in a register with a byte pointed to by a register pair, and increment the pointer if the condition is not met. If the condition is met, the pointer is not incremented and the branch is taken. Example:

; Find the position of a letter in a text.

Message: .ascii "This is a trial"

```
ld       rr0, #Message      ; where to search
ld       r2, #'t'          ; the character to search for
```

Search:

```
cpjfi    r2, (rr0), Search    ; this is the search loop

...          ; here rr0 points to the 11th character of message
...          ; continuation
```

### 3.3.1.7 Far Branch

As explained in Section 3.1.7, the 4-Mbyte memory is a segmented memory. It is not possible to reach another segment with the common CALL, RET and JP instructions because they do not manage the CSR (Code Segment Register) register. This is managed by the three new CALLS, RETS and JPS instructions. Only 2 to 4 cycles are added to the common instructions.

### 3.3.1.8 Optimized C Instructions

In C functions when a function is called, the compiler needs to push the variables in the user/system stacks and to keep the return address location of the function inside the stack.

Therefore, a frame pointer is used, and 2 pieces of code named prologue and epilogue need to be added by the C Compiler at the beginning and at the end of the function respectively. The LINK and UNLINK instructions (LINKU, UNLINKU to use the user stack) are used to reduce the code overhead generated by the compiler inside the function. These instructions are automatically added by the C Compiler instead of prologue and epilogue (if option -mlink is specified).

The number of cycles gained by using these instructions is about 34 to 42 cycles and 8 bytes per called function.

### 3.3.2 Advantages when Using C Language

The ST9+ has been designed with high-level languages in mind. In particular, the instructions described above are of special interest to C programmers.

First, as a structured language, C typically uses the stack to pass arguments to functions, return values from functions, and store the local variables of the functions. An instruction such as:

```
pushw #1500
```

pushes a constant integer value as the constant argument of a function. This is used in the following example:

```
/* define a function that has a single argument of int type */
void MyFunction ( int Param ) ;
{
```

```
    /* body of the function */
}

void main ( void ) ;
{
    /* some code ... */
    MyFunction ( 1500 ) ; /* invoke this function with a constant argument */
    /* more code ... */
}
```

Since C makes heavy use of pointers, the instruction:

```
    pea 4(rr2)
```

pushes the address of the 5th byte of a structure.

For example:

```
/* define a structured type */
struct sMyStruct {
    int N1 ;
    int N2 ;
    char C1 ;
} ;

struct sMyStruct MyStruct ; /* create a variable of the above defined type
*/

/* define a function that has a single argument of type pointer to character
*/
void MyFunc ( char * Arg ) ;
{
    /* body of the function */
}

void main ( void ) ;
{
    /* some code */
    /* invoke the function with the address of the character element of the
structure */
}
```

```

MyFunc ( &MyStruct.C1 ) ; /* &MyStruct.C1 = 4(rr2) if rr2 contains the
address of MyStruct */
/* more code */
}

```

The `lddd`, `ldpp`, `lddp`, `ldpd` instructions are used for block copies such as assignments of structures, etc.

Powerful addressing modes such as indirect, indirect with increment or decrement and indexed shorten the code needed to access data even in structures or arrays. They also facilitate access to local variables created on the stack on entering functions. Working registers that benefit from the most powerful instructions and addressing modes are heavily used by the compiler. In fact, the GNU9 compiler does not always translate the source code as suggested above. There are optimization schemes that save execution time and/or memory by judiciously allocating the working registers, so that in many cases arguments are not pushed to the stack, but merely to an available working register.

### 3.4 INTERRUPTS

The interrupt system of the ST9+ is very powerful, and, in consequence, requires some thorough study to get the most out of it. However, it is worth learning since it allows you to build very efficient programs with excellent interrupt response times.

The ST9+ interrupt system works the same as that of any microcontroller, except for two points that call for special attention: the vector mechanism and the priority mechanism<sup>(4)</sup>.

#### 3.4.1 Interrupt Vectors

Unlike most microcontrollers, the ST9+ uses a two-level indirect interrupt vector system. This means that each peripheral able to generate interrupt requests has a vector register that points to a location in program memory (the vector array). This location contains the address of the start of the interrupt service routine. This allows each peripheral to generate several different interrupt requests: the peripheral vector register points to an array of pointers to routines, each routine responding to a different interrupt cause. All pointers to interrupt processing routines, except the Reset, must be located in the first 256 bytes of the Interrupt Service Routine (ISR) segment (one of the 64 code segments). The trap for divide by zero with the associated far call to the Interrupt Service Routine has to be repeated in all memory segments containing programs that perform division. Code may also reside in this 256-byte space, provided that it does not overlap with the interrupt vectors.

Figure 13 shows the complete mechanism of the 22-bit address construction from the interrupt which provides the Interrupt Vector Register value to the return from interrupt.

<sup>(4)</sup> Device Datasheet; Interrupts § 4.

For each peripheral, the layout of the vector array is specified in the section related to its own Interrupt Vector Register.

**Figure 13. Interrupt Vectors**

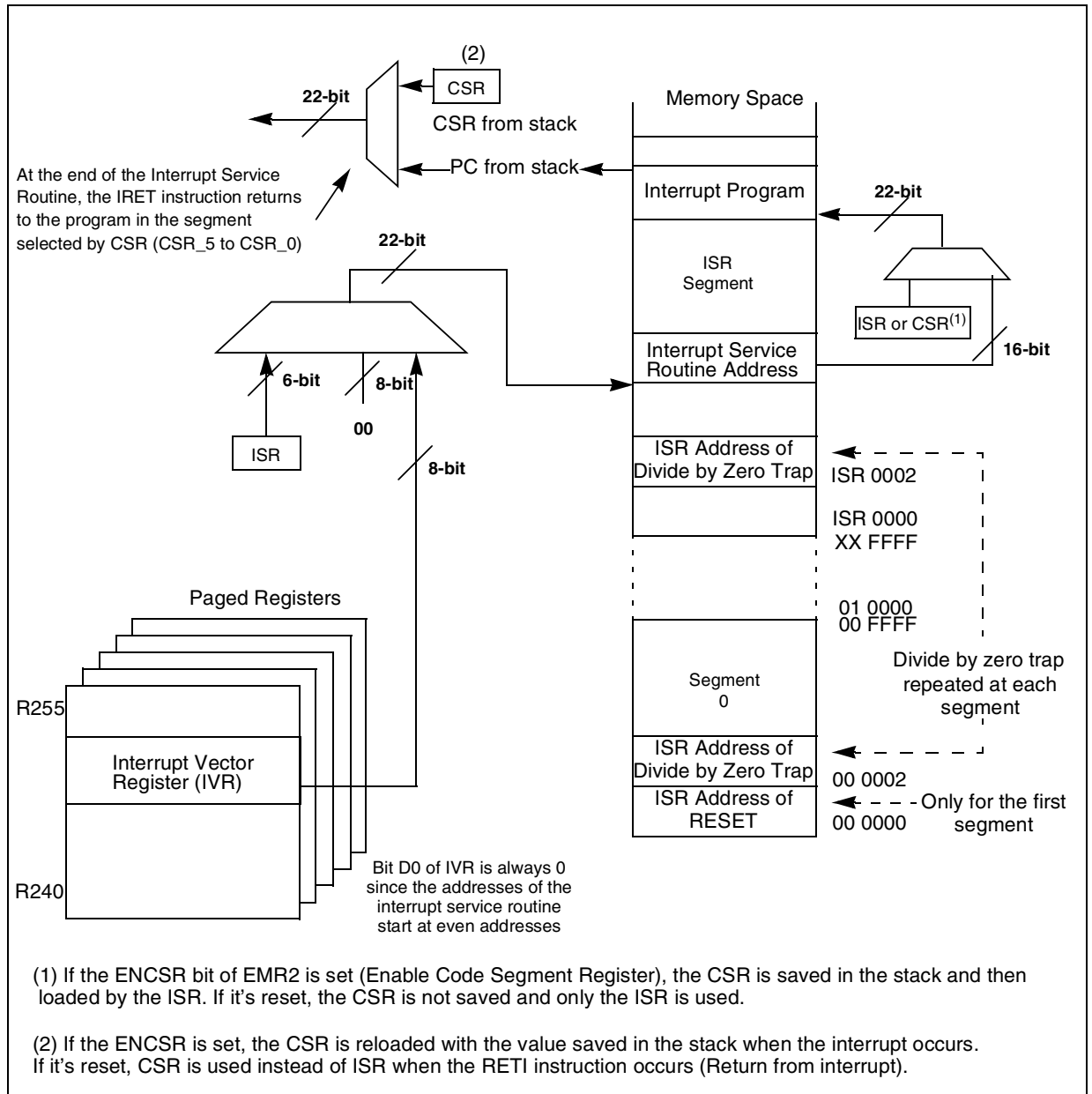

As an example, let's take the ST90158 Multifunction Timer 0. The registers that define the MFT0 functions are all contained in pages 9 and 10 of register group 15 (0FH). Register 242, called the Interrupt Vector Register (IVR), holds the address of the beginning of the vector array in program memory. The IVR has the following bit layout:

## T0\_IVR (R242 page 9)

V4	V3	V2	V1	V0	W1	W0	'0'
----	----	----	----	----	----	----	-----

Where V4-V0 (fixed by software) are the high bits of the low byte address memory where the vector for the first interrupt cause is located. Since there are three different interrupt causes, and the address of each interrupt service routine occupies two bytes, the IVR must be loaded with an address between 8 and 250 that is a multiple of 8 (i.e. the lower three bits are zero). The layout above shows two bits W1 and W0 (fixed by hardware), and a third bit that is permanently set to zero. The two W1-W0 bits code four different possible interrupt causes, as in the following table:

W1	W0	Interrupt Source
0	0	Overflow/ Underflow event interrupts
0	1	Not available
1	0	Capture event interrupts
1	1	Compare event interrupts

When an interrupt occurs, the resulting value is an address that is the value written in IVR (here 40H), plus the value coded by the cause (if the cause is a capture event, W1-W0 are 10, thus the value is 4).

This gives an even number, since the least significant bit is zero, as follows:

V4	V3	V2	V1	V0	W1	W0	0
0	1	0	0	0	1	0	0

So IVR points to address XX 0044H (with XX the ISR segment number), which must contain a word that is equal to the address in the ISR segment of the Interrupt Service Routine for that cause.

An example of the code for setting the IVR is:

```
void ConfigTimer0 ( void )
{
  /* setting other registers... */

  SelectPage (T0C_PG) ;
  T0_IVR = (unsigned char) INTRELOADVECT ; /* Array of pointers to service
  routines in ROM */

  /* setting other registers, continued... */
}
```

Figure 14. Interrupt Vectors: Example with Multifunction Timer 0

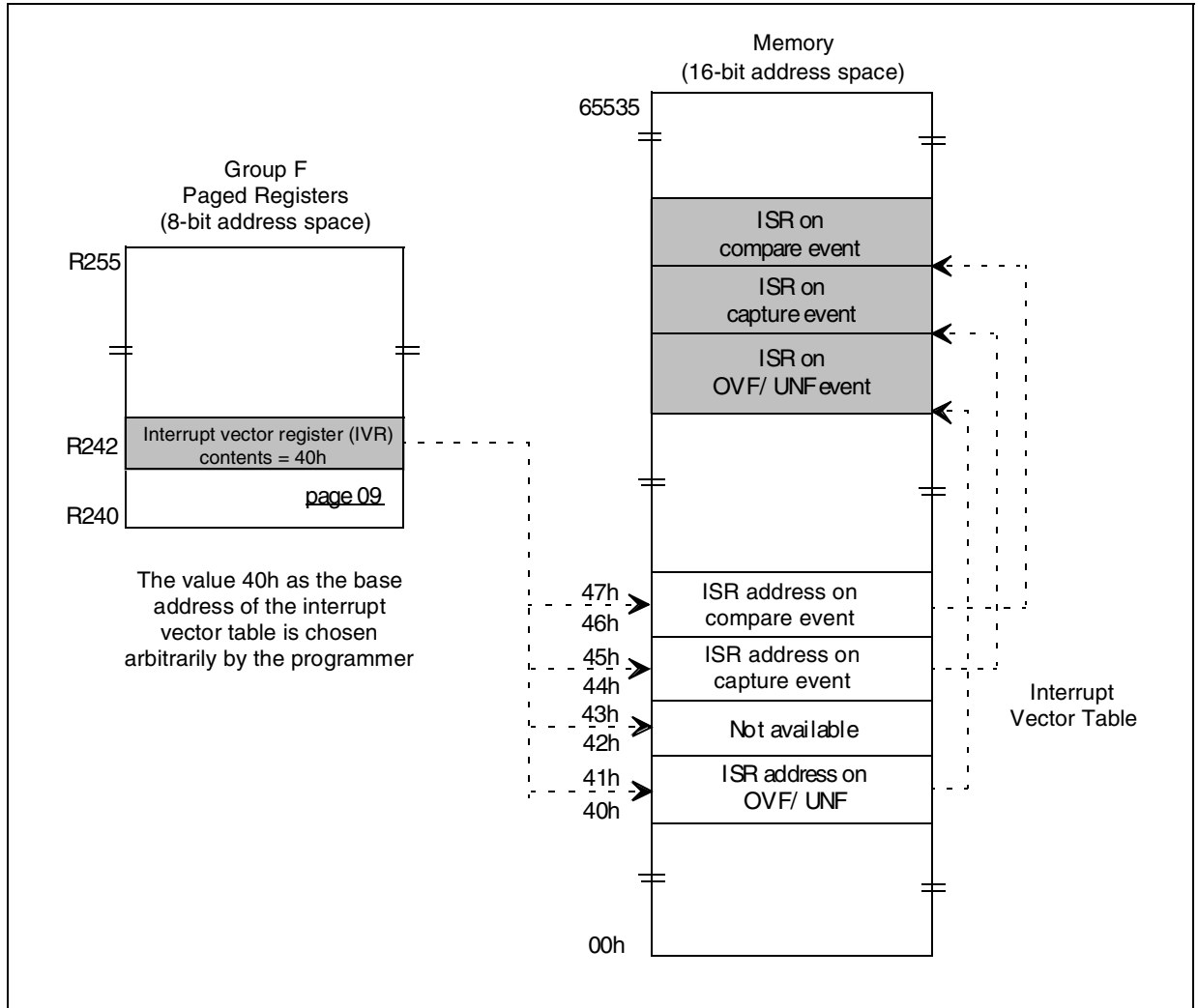

The corresponding source code could be:

```

; This program uses the 3 interrupt possibilities of MFT0

; Constants
IT_MFT0_VECT = 40h

; Vector table
.section.text
.org 00h ; (default address)
.word Reset ; reset vector
- ; if needed divide by zero, NMI vectors
-
    
```





is disturbed, the sooner it finishes its job. On the other hand, we often need to serve interrupt requests generated by the peripherals as quickly as possible. Since this is a trade-off, we need to find a compromise that gives both enough power to the main program while still keeping it as responsive as possible to interrupts. It is likely that we will need to modify this compromise according to the current status of the program.

If we define that some interrupt requests are more urgent than others, we can define a priority or a hierarchy of interrupt requests. The main program itself, if given a priority level, should be considered as having the lowest priority (except sometimes when interrupts are undesirable).

In most cases, when the main program is running, it can be interrupted by any interrupt request. But once a request is being served, it most likely needs to continue undisturbed, unless a request from a higher priority level occurs. Then, the higher priority request is served until completion. The service routine then returns to the lower priority interrupt service routine, that terminates and eventually returns to the main program. In the ST9+, this behavior is called Nested Mode.

Other types of behavior may be required depending of the kind of processing. For this, the ST9+ interrupt system has two Boolean parameters to select the way interrupts are handled, which allow four basic choices.

The priority mechanism is driven by the Current Priority Level parameter. At a given time, the part of the program being executed runs under a certain level. You can change this CPL by writing a different value in the core's Central Interrupt Control Register (CICR). You can assign Priority Level (PL) to each interrupt source. At initialisation time, this value is written in one of the control registers specific to the corresponding peripheral.

**Note:** The PL is a three-bit word that ranges from 0 to 7. Note that 0 stands for a high priority and 7 for a low priority. These bits belong to one of the configuration registers of each peripheral.

When a peripheral requests an interrupt, the built-in interrupt controller compares the priority level of the interrupt request to the Current Priority Level. The interrupt is only acknowledged if its priority level value is strictly less than (higher priority) than the Current Priority Level value. This allows you to filter out interrupt requests according to their degree of importance or of urgency according to the current activity of the program. The Non-Maskable Interrupt input (NMI) is hard wired with a higher priority than any level, and thus is acknowledged immediately in all circumstances.

The ST9+ offers two modes for managing interrupt priorities:

- Concurrent Mode
- Nested Mode

The difference between them is explained below.

### 3.4.2.1 Global Interrupt Enable Flag

In both modes, when an interrupt request is acknowledged, the Interrupt ENable (IEN) bit is cleared, preventing the interrupt service routine from being interrupted again until it is finished. If required, you may prefer to keep it cleared for the duration of the routine or to set IEN at some place in the routine using the `ei` instruction. In the first case, if an interrupt request of a sufficient priority level is received, it will only be serviced as soon as the service routine currently running returns. In the second case, the same interrupt request is serviced as soon as both it occurs and the IEN bit is set. In short, interrupt service routines may be re-interrupted or not, at will.

### 3.4.2.2 Concurrent Mode versus Nested Mode

Selecting either Concurrent Mode (automatically chosen on reset) or Nested Mode changes the way the Current Priority Level is managed.

In Nested Mode, the CPL is automatically set to the priority of the current interrupt service routine, and is reset to the previous value on return. This allows you handle the interrupt request according to priority at all times, since during the execution of the service routine for a given interrupt, only those interrupts whose priority is strictly higher than that of the one currently being served will be taken into consideration. Then if, as must normally be done, the IEN bit is set during the current service routine, it will be interrupted at once if an interrupt request of higher priority occurs. If the IEN remains cleared for the whole duration of the service routine, those interrupt requests will be served first after the current routine has returned.

Figure 15. Example with Nested Interrupts Enabled

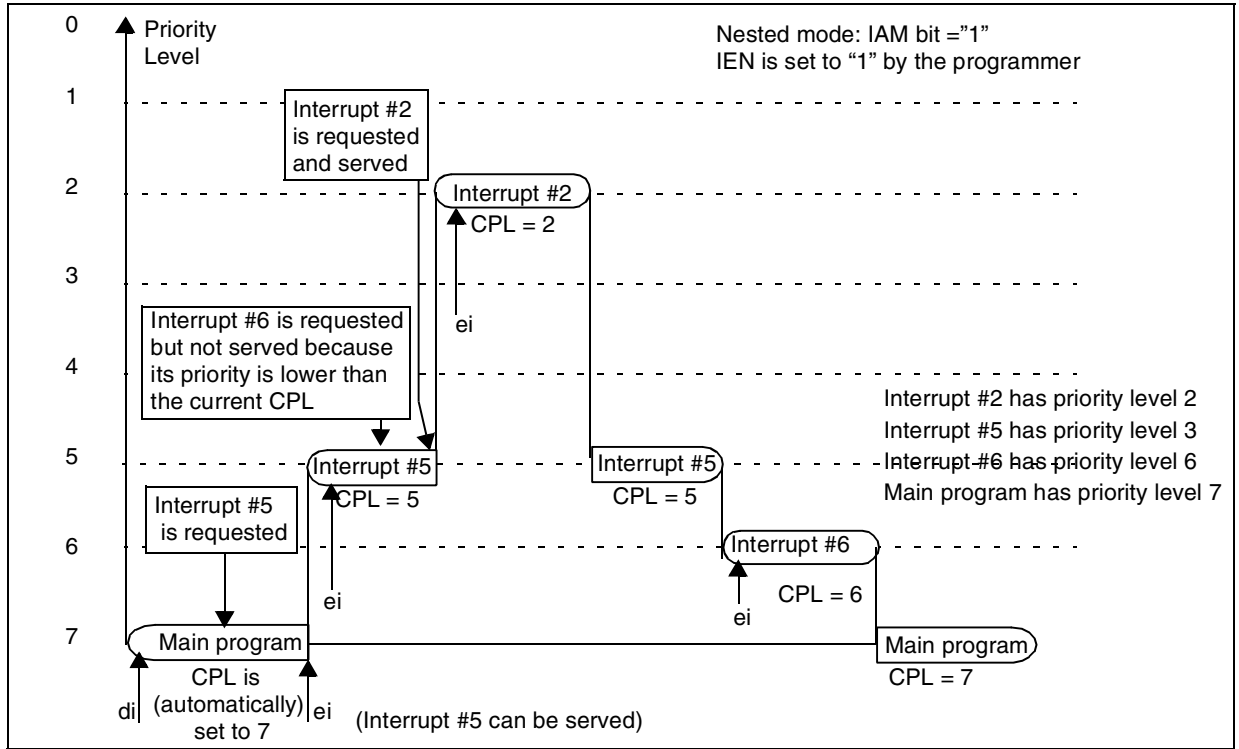
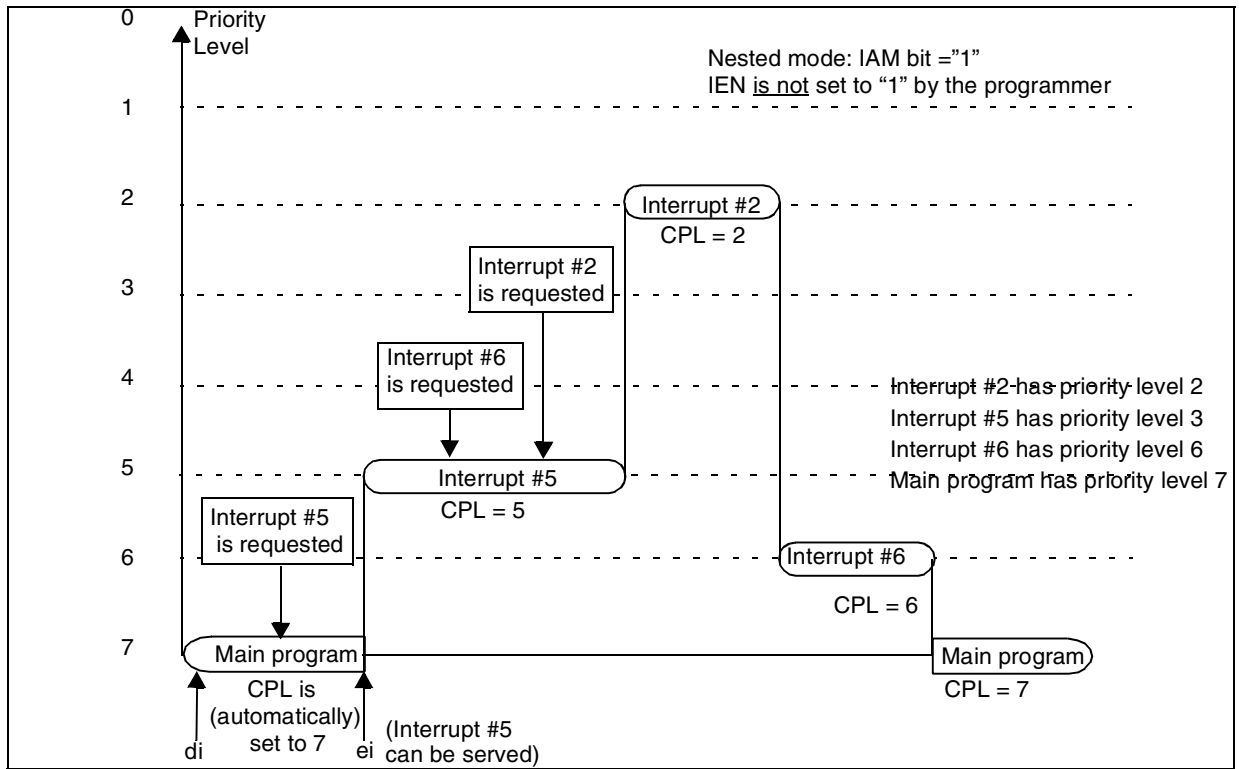
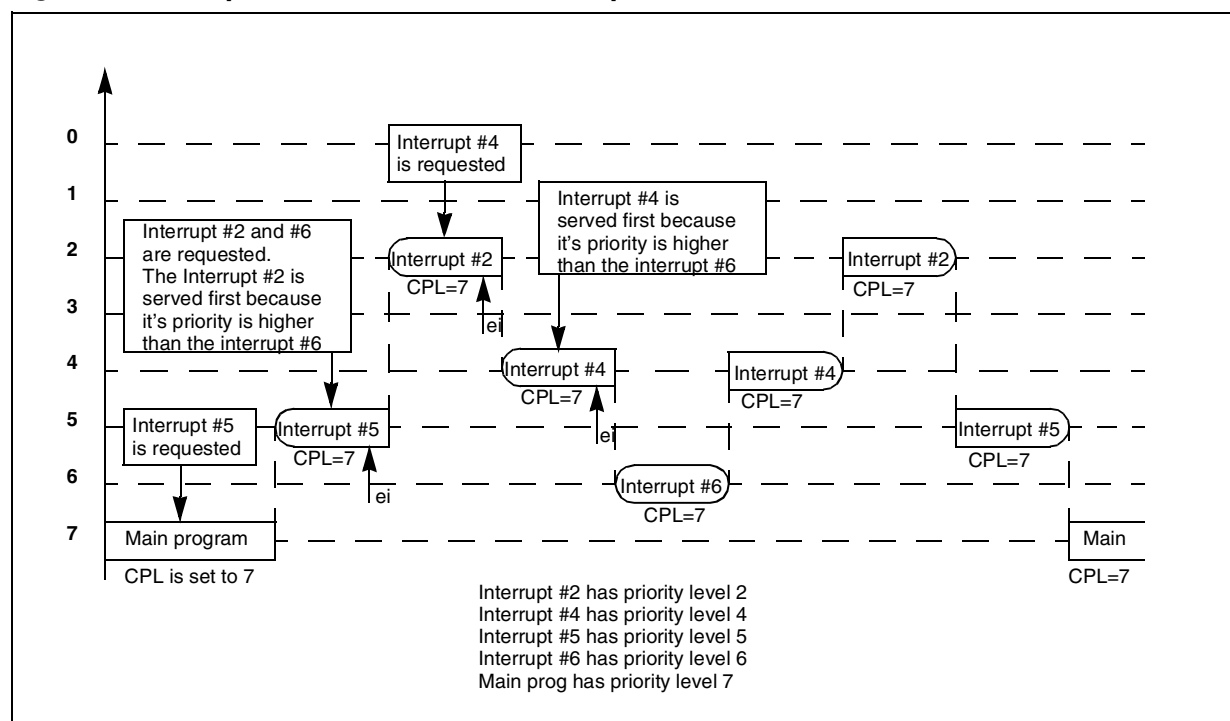

Figure 16. Example with Nested Interrupts Disabled



In Concurrent Mode, the CPL is set exclusively by the programmer. You can change it if you need to shift the compromise mentioned above either towards main program efficiency, or towards short interrupt latency times. So you can have a high-priority service routine that is re-interrupted by a low-priority interrupt request, if the CPL has been set to a low priority and the IEN bit is set. This mode gives you maximum flexibility, but it is the most difficult to use since you must keep track of every combination of interrupt requests to achieve the efficiency you expect from your program.

**Figure 17. Example with Concurrent Interrupts Enabled**



Concurrent mode does not look like a reasonable way to handle interrupts if you enable interrupts in your interrupt service routine. It should be thought of as a way to fully control priorities through programming, if nesting priorities cannot meet your processing requirements. For example, let us consider the case when a timer produces a periodic interrupt that outputs some data on an external digital to analog converter. The requirement is that the new data be output at the very time of the interrupt, so as to reduce the jitter (or parasitic frequency modulation) that would compromise the spectral purity. Then, once the data is output, the interrupt service routine does some processing to make or get the data for the next interrupt. The latter part of the processing is much less critical in terms of execution time, provided it is finished before the next timer interrupt. Using Concurrent mode, you can assign that interrupt the highest priority so that it will be served immediately, then re-enable the interrupts and, if needed, give it a pri-

riority level as appropriate. The service routine will then allow other interrupts to gain control, at the expense of delaying its own completion.

**Note 1:** In practice, Concurrent mode does not differ much from nested mode if the interrupts are not re-enabled during an interrupt service routine. Concurrent Interrupts Disabled looks like Nested Interrupt Disabled with the difference that the CPL is changed only by software when necessary. The interrupt requests pending while the interrupt service routine is executing, will only be serviced after the current service routine returns.

**Note 2:** An interrupt with priority level 7 will never be served.

### **3.4.3 External Interrupt Unit**

This is a functional block that can receive interrupt requests from up to eight external pins, and also from some internal devices such as the Watchdog Timer, the Serial Peripheral Interface, etc. It is used to select the active edge for pin or device, and define the priority for each of the four pairs. In addition, an NMI pin can be programmed as being maskable or non-maskable. It is maskable on reset, and once set to non-maskable, it cannot again be set to maskable until the next reset. This works as explained below.

#### **3.4.3.1 Maskable External Interrupt Pins**

These are eight external inputs you can set individually to rising-edge or falling-edge sensitive, and masked. You assign priorities by pairs, making four groups with different priorities. Within each group, the two interrupt requests have two successive priorities. For example, if you set group C to priority 2, the INT4 input will have priority 2 and INT5 will have priority 3 (which is lower).

The simplified block diagram is the following:

**Figure 18. External Interrupts Simplified Block Diagram**

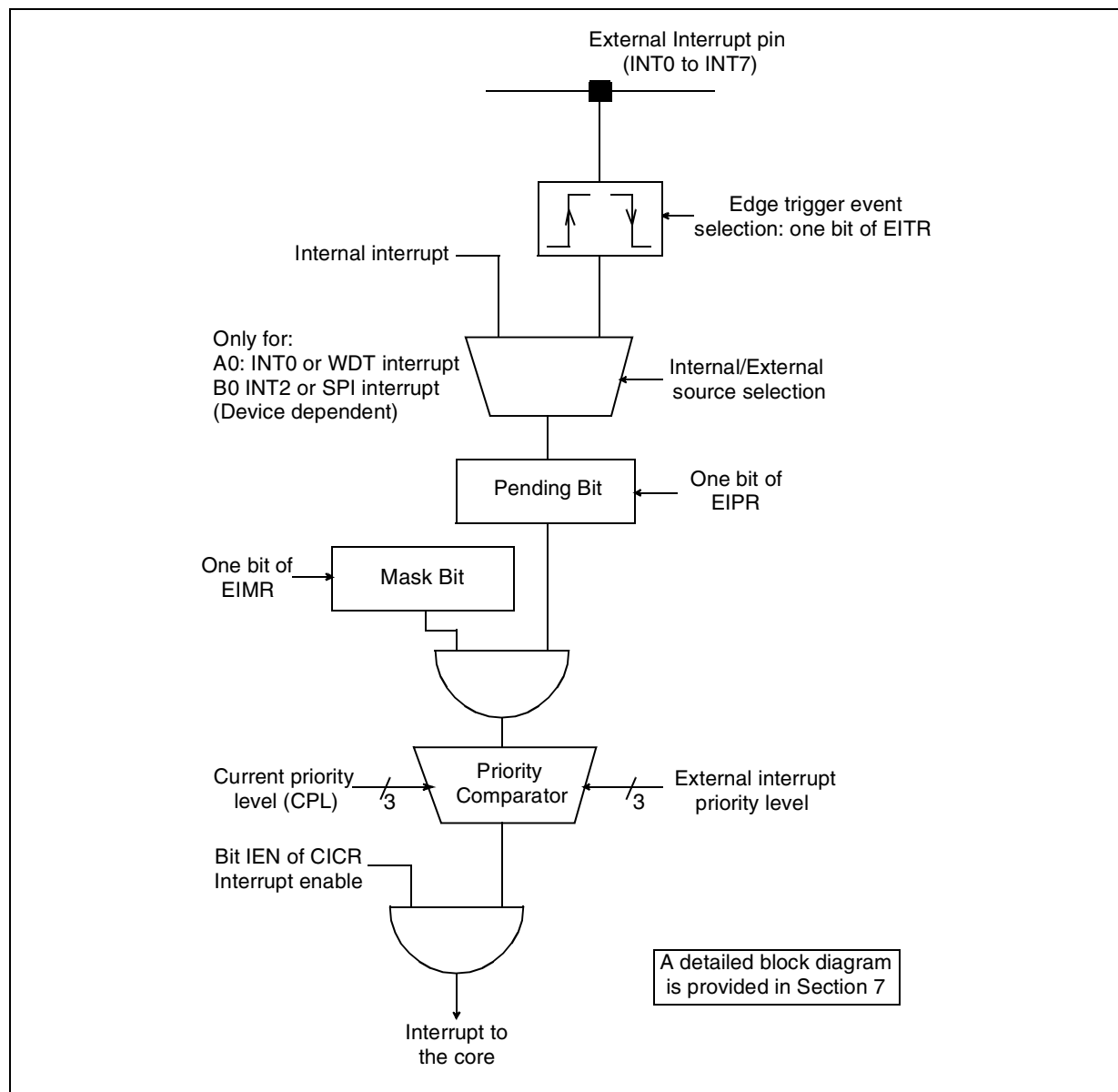

### 3.4.3.2 Top-Level Interrupt

The Top Level Interrupt can have two sources: either the NMI pin, or the watchdog end-of-count<sup>(5)</sup>. This interrupt level has a special feature that allows you to mask it like any other interrupt, or to make it a real non-maskable interrupt. For this, the TLNM bit (see Figure 19) can remove the effect of the mask. Once set, it cannot be reset, thus preventing this interrupt from

<sup>(5)</sup> See Section 4.3 on the Watchdog Timer.

being accidentally masked even in the case of a program failure. In any case, the Top Level Interrupt uses the third fixed vector at addresses 4 and 5 in program memory. As the name implies, it has a fixed priority that is higher than any other interrupt request. Though it does not clear the IEN bit when acknowledged, unlike all other interrupt requests, its service routine cannot be interrupted by any cause, including the Top Level Interrupt itself.

The simplified block diagram is the following:

**Figure 19. Top-Level Interrupt Simplified Block Diagram**

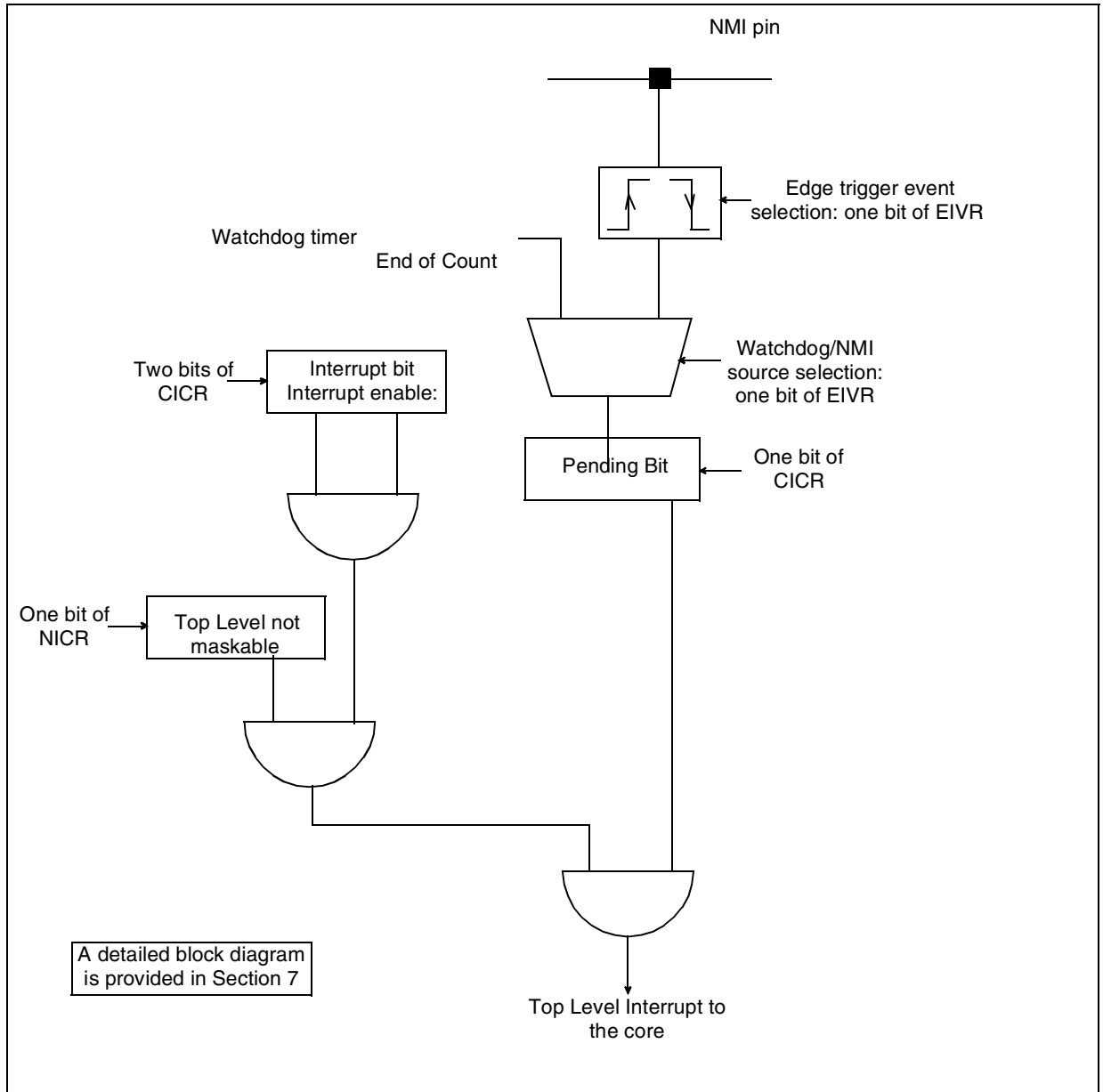



### 3.4.3.3 External Interrupt Vectors

There are eight external interrupt causes. They are each connected to an external input that is the alternate function of an I/O port. Some of these are shared with other causes in an exclusive manner, i.e., the INT0 pin is multiplexed with the Watchdog/Timer interrupt request, and the INT2 pin is multiplexed with the Serial Peripheral Interface interrupt request (on the ST90158). Each cause is associated with a separate vector in Program Memory. All vectors are contiguous, generating an array of 8 vectors starting with the INT0 vector, and ending with the INT7 vector. This array may be freely located in program memory between addresses 8 to 240 (0F0h) in program memory.

These interrupt causes are grouped by pairs, and are given new names inside the interrupt controller, as shown in the following table:

Interrupt Source	Interrupt Cause
INT 0	INT A0
INT 1	INT A1
INT 2	INT B0
INT 3	INT B1
INT 4	INT C0
INT 5	INT C1
INT 6	INT D0
INT 7	INT D1

You can independently assign a priority to each pair (A, B, C, D), with levels that are multiple of two, i.e. you can set them to priority levels 0, 2, 4, or 6. In each pair, the cause bearing the figure zero assumes this priority, and the cause bearing the figure 1 assumes the next level above. For example, if you assign level 4 to pair C, this means that INTC0 will have level 4 and INTC1 level 5. You set this in register EIPLR (R245 page 0), where each group of two bits gives the level of the corresponding interrupt cause.

The interrupt vectoring is summarized in the table below:

Figure 20. External Interrupt Vectors

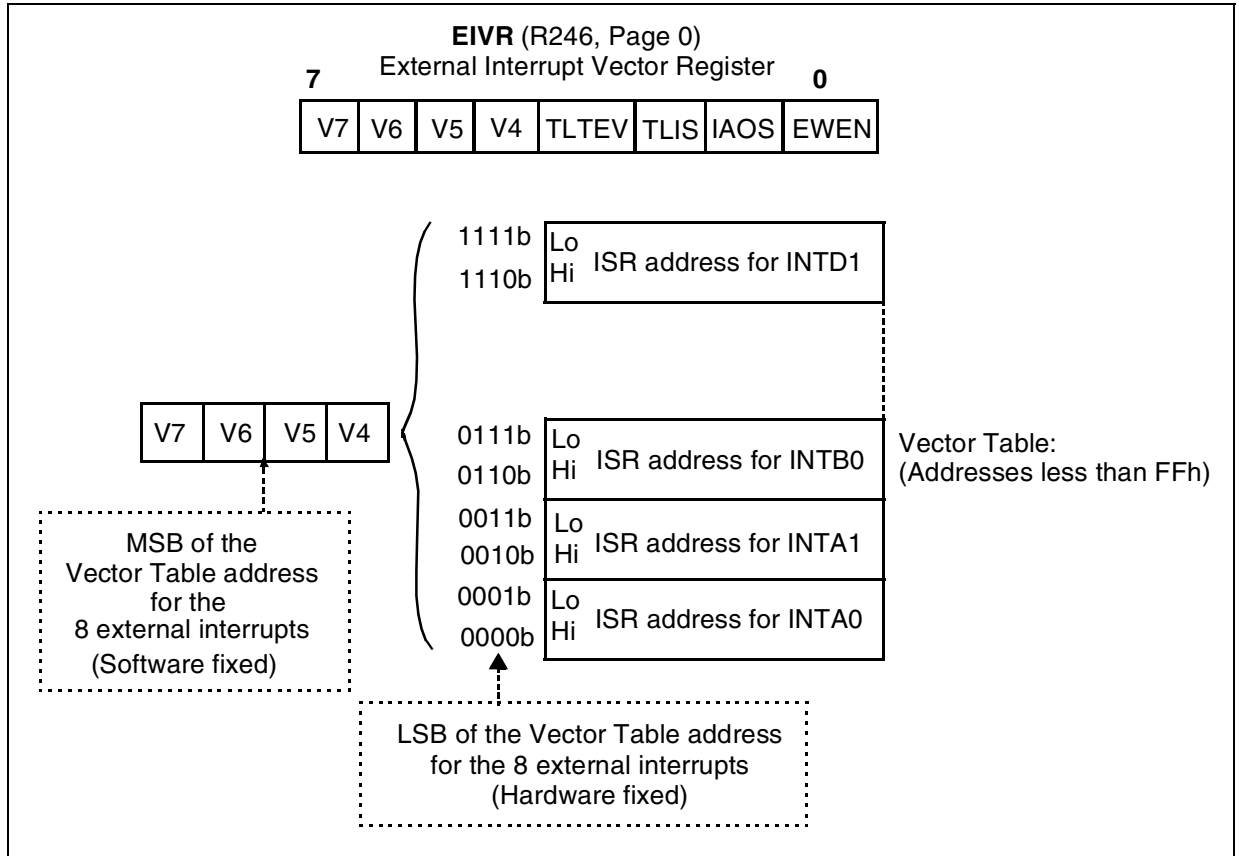

### 3.5 DMA CONTROLLER

#### 3.5.1 Overview

One of the most important advantages of the ST9+ is its ability to handle input/output data flows without using core instruction cycles. This is made possible by the built-in DMA controller. Once properly initialized, it allows peripherals to exchange data either with memory or the register file, with no more use of the core resources than the stolen memory cycles strictly needed to transfer the data.

To see how much faster DMA is than the simplest interrupt service routine, let us compare the execution times.

Let us assume that the data comes from the serial port. The simplest interrupt routine is the following:

```
GetOneByte:; interrupt latency:                22 cycles
    push    PPR                                ; save current page      8
    pushw  rr0                                ; save rr0                    10
    spp    #SCI_PG                             ; change register page       4
```

ldw	rr0, POINTER	; get pointer	12
ld	(rr0)+, S_RXBR	; move data	12
ldw	POINTER, rr0	; store pointer	14
popw	rr0	; restore rr0	10
pop	PPR	; restore current page	8
iret		; return	16
		; -----	
		; Total:	116

With an internal clock of 25 MHz, this corresponds to an execution time of 4.64  $\mu$ s. In contrast, the DMA cycle time for the transfer of one byte from a register to a register file takes only 8 cycles (16 cycles to the memory), that is 0.32  $\mu$ s. The DMA feature saves you from using valuable core processing power for simple tasks like storing an input byte to memory. For example, if a continuous flow of data is input at 19200 bits per second, the interrupt service routine would consume 1.11% of the total cycles of the core, as compared to the 0.0767% with the DMA solution. Since the DMA is built-in and works with most of the peripherals, it is a good idea to use it even for slow transfers.

The DMA uses the Segment mechanism to address 64 Kbytes along the linear 4 MBytes. See Section 3.1.7 for more details.

### 3.5.2 How the DMA Works

The DMA consists of a transfer between a memory or register file and a peripheral, in either direction. Assuming the peripheral is configured to handle externally supplied data or to provide data to external circuits, two steps are needed for a transfer to occur.

The transfer must be requested by some event or condition.

A mechanism must handle reading the data from one part and writing to the other part.

The term DMA transfer represents the transfer of a single byte of data. Usually, more than one byte is transferred and the transfer occurs in bursts. Thus, a third step is involved:

A mechanism that counts the transfers and stops them when the count is finished.

To the programmer, these mechanisms appear as registers to be properly initialized. The three steps are handled as follows (see Figure 21).

#### 3.5.2.1 Transfer Requests

The DMA transfer is requested in exactly the same way as an interrupt is requested. According to its type, the peripheral concerned sends a request based on an external event such as a character received or transmitted by the Serial Channel Interface. You configure this in the registers belonging to the peripheral involved. Special bits in the registers indicate that the peripheral ready status, instead of requesting an interrupt, requests a DMA transfer.

### **3.5.2.2 Transfer Execution**

A DMA transfer can involve a memory location or a register in the register file. In any case, the transfer requires an address and a counter. This address and counter are stored in registers which you can define anywhere in the register file. The address register value is automatically incremented after each transfer and the counter register value is decremented so that the next transfer will involve the next address and this mechanism will continue until the counter is equal to 0. Depending on whether the transfer addresses memory or the register file, there are two cases.

If the transfer addresses the register file, the address register and the counter register are single registers (a byte is enough to address 256 registers). The address of this address register is stored in one of the peripheral's registers, named DCPR. The low bit (RM) of this register is set to zero indicating that the register file is involved in the transfer. The address register must have an even address to address the DMA address, the next register storing the DMA transaction counter.

If the transfer addresses the memory, the registers that hold the address and the counter must be two double registers. In this case, the DMA address is pointed by the DAPR pointer register and the DMA transaction counter is pointed by the DCPR pointer register. The low bit of the DAPR indicates whether the memory segment is pointed by DMASR or ISR (see Section 3.1.7). The DMA address and the DMA transaction counter are not necessarily consecutive.

### **3.5.2.3 Transfer Termination**

A burst terminates when the count of transfers reaches a predefined value. To set this up, you set a counter register in the register file that holds the count of transfers to execute at the start of a burst. Each transfer decrements it, and the DMA mechanism is stopped when the counter reaches zero.

The way DMA controller terminates the transfer differs from one peripheral to another, but typically it consists of resetting the bit in the configuration register that tells the peripheral to issue DMA requests instead of interrupt requests. Then, on the last transfer, when the transfer counter reaches zero, it toggles the DMA/Interrupt request bit so that the peripheral issues an interrupt request again. If this request is unmasked, you should vector it to an interrupt service routine that handles the DMA termination.

#### **To summarise:**

For register transfers, the DCPR of the peripheral points to a user-defined pair of registers that holds the address and the count. Register DAPR is unused. For memory transfers, the DAPR points to the user-defined register pair that holds the address. The DCPR register points to the user-defined register pair that holds the count.

Some peripherals, such as the Multifunction Timer, even have a double pair of DAPR/DCPR registers. Only one pair is used at a time. In so-called Swap Mode, this allows the timer to use one data buffer for output and another buffer for input. The pair of registers used is automatically changed when one transfer burst terminates, allowing a continuous data flow between the program and the peripheral, with minimum data handling overhead.

In addition, the MFT has 16-bit registers. Transfers imply two byte transfers for each register. This is ensured by a mechanism that gives the DMA the highest priority as soon as the first byte is transferring. This guarantees that the second byte will also be transferred in the shortest delay, even if other DMA requests become pending while the transfer is in progress.

**Figure 21. DMA Data Transfer**

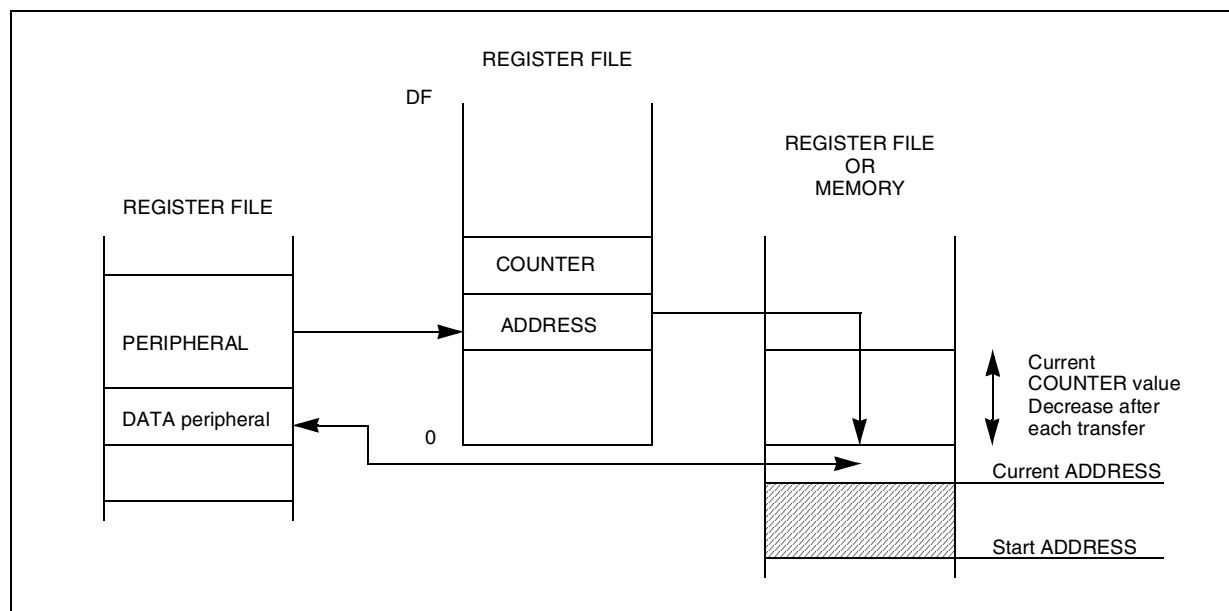

### 3.6 RESET AND CLOCK CONTROL UNIT (RCCU)

The **RCCU** is composed of the Clock Control Unit (**CCU**) and the Reset and Stop Manager.

#### 3.6.1 CLOCK CONTROL UNIT

The **CCU** generates the peripheral clock **INTCLK** and the CPU clock **CPUCLK**. It is a useful clock generator with low power function and low external frequency oscillator to reduce electromagnetic emissions.

The diagram can be reduced as in Figure 22.

Figure 22. CCU Simplified Block Diagram

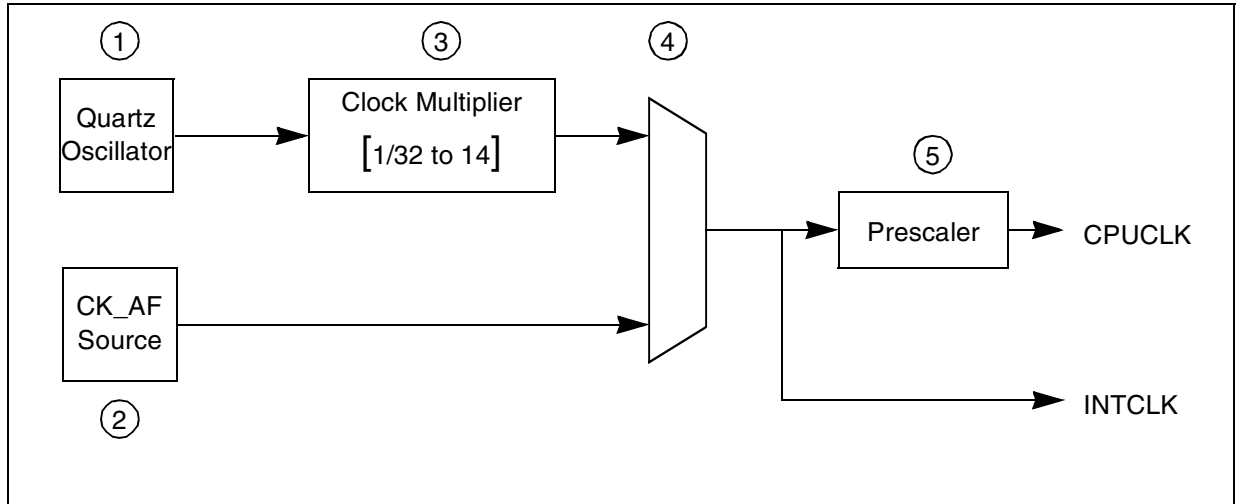

The CCU is composed of 5 main blocks:

BLOCK	COMMENTS
1	Quartz oscillator gives the main frequency generator. The frequency is in the range of 3 to 5 MHz.
2	External clock for very low power consumption with a very low frequency.
3	The Clock Multiplier can reduce or increase the input frequency by using prescaler and PLL. The increase is for the normal use and the decrease for low power consumption.
4	The selector aims the clock coming from the Clock Multiplier for normal or low power use or aims the clock CK_AF for a very low power consumption.
5	The prescaler is used also for low power consumption. The INTCLK is not change giving a high frequency to the internal peripheral. This allows the user to slow down program execution during non processor intensive routines.

### 3.6.1.1 Clock Multiplier

The Clock Multiplier is a part of the Figure 24.

The advantage of the Clock Multiplier is that it can produce a variable clock frequency depending on the needs of the CPU.

Since the input clock to the PLL circuit requires a 50% duty cycle for correct operation, the divide by two should be enabled (DIV2 bit of MODER register set) if the PLL is enabled. It is necessary when a crystal oscillator is used, or when the external clock generator does not provide a 50% duty cycle. In practice, the divide-by-two is virtually always used in order to ensure a 50% duty cycle signal to the PLL multiplier circuit.

The Clock Multiplier output is one of the CLOCK2, CLOCK2/16 or  $CLOCK2 * PLLMUL / (DX + 1)$  (PLLMUL is the PLL multiplier coefficient) frequencies.

The two frequencies CLOCK2 and CLOCK2/16 are for low power consumption or reduce power consumption, depending on the Wait For Interrupt instruction (refer to the flow chart Figure 23).

The PLL has four clock multiplier factors (6,8,10 and 14) controlled by the two bits MX0 and MX1 in the PLLCONF register. The clock divider is controlled by three bits DX0:2 in the PLLCONF register for seven rates which are  $1/(DX+1)$ . Setting DX2:0=7 turns OFF the PLL to reduce consumption.

When you switch on the PLL, you have to allow a delay for the PLL to lock.

**Figure 23. INTCLK and CPUCLK Flow Chart**

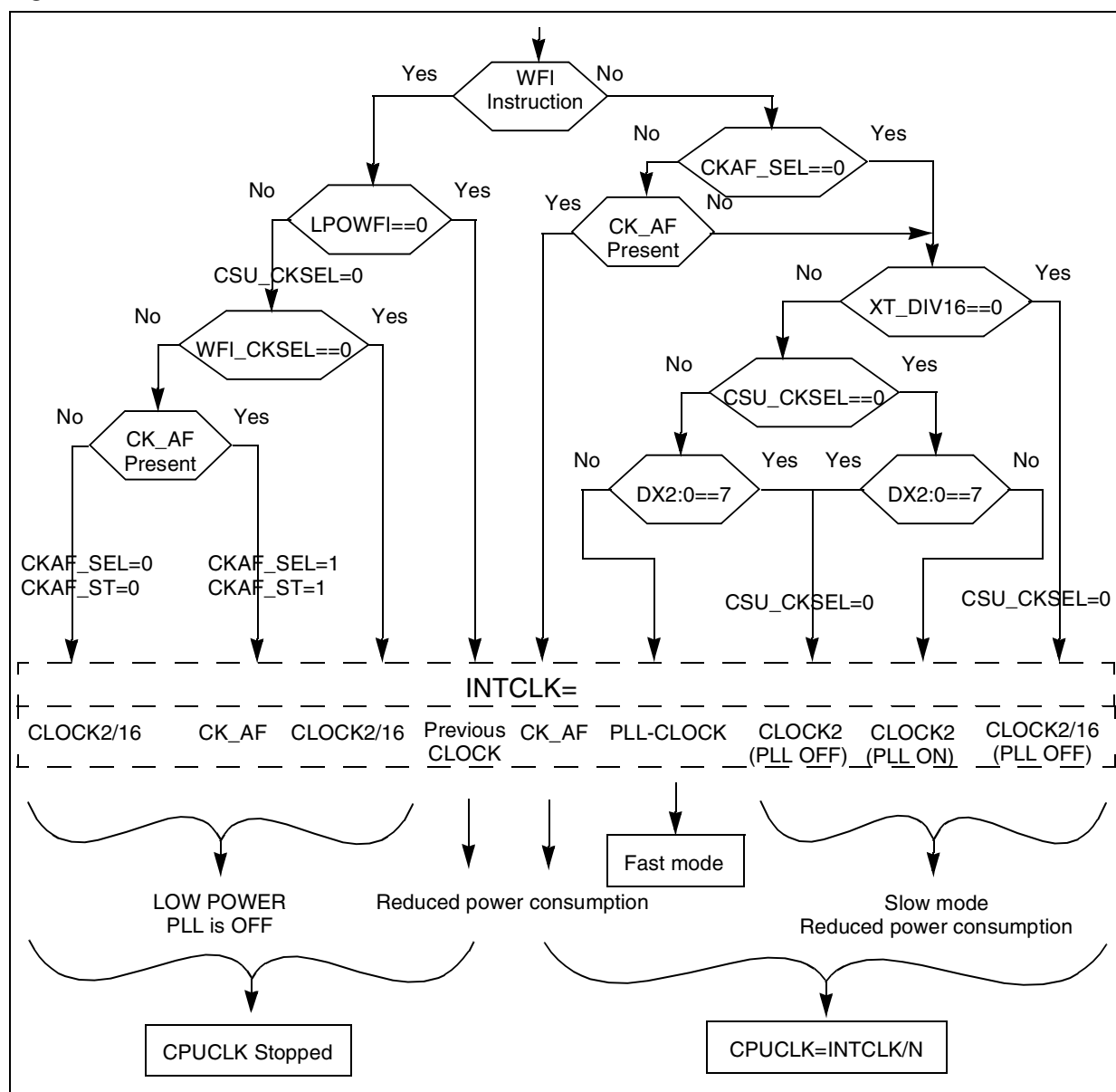
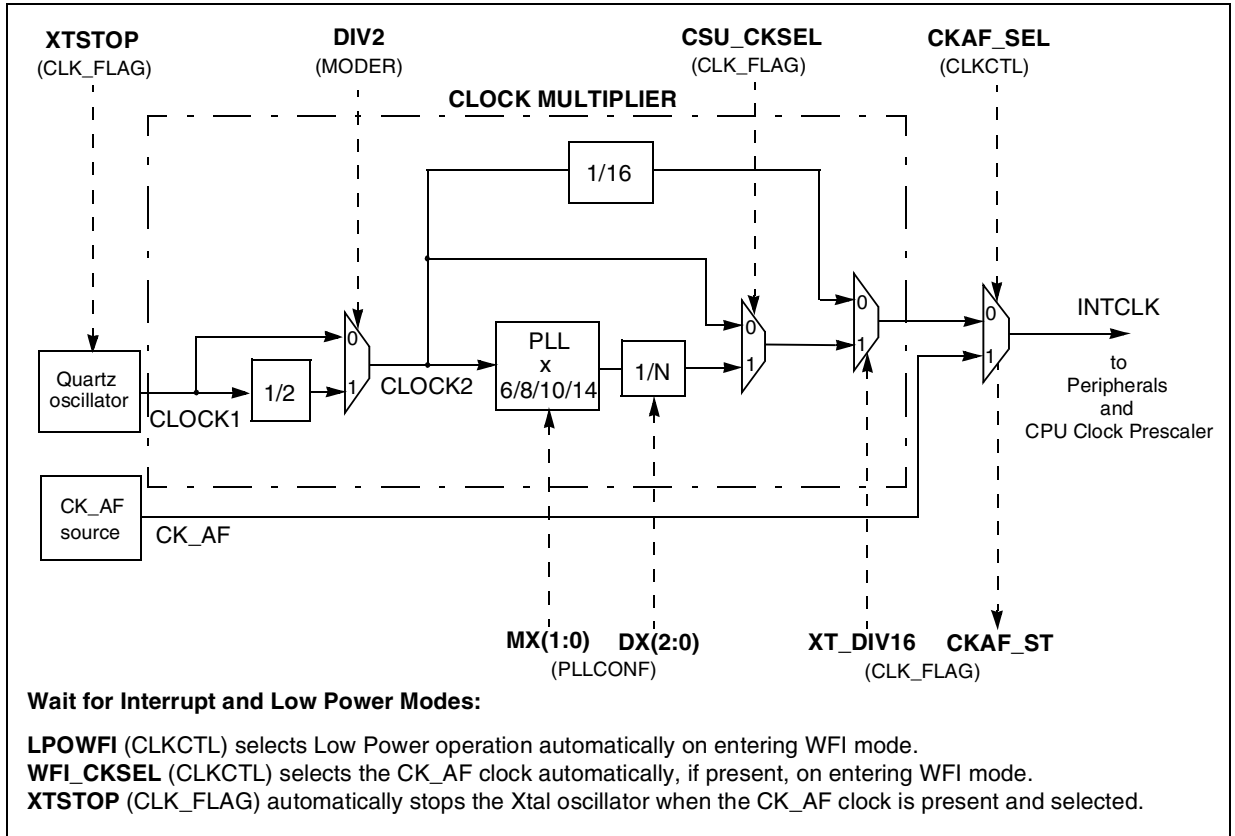

Figure 24. Clock Control Unit Programming



### 3.6.1.2 CK\_AF Source

When you execute a Wait For Interrupt (WFI) instruction using the Clock Multiplier with output clock CLOCK2/16, the power is put in Low Power mode. To reduce this power further you have the possibility of slowing down the INTCLK frequency by using an external clock source CK\_AF. The CK\_AF clock will be selected if the WFI\_CKSEL bit in the CLKCTL register is set and if CK\_AF is present.

The CK\_AF source can also be used in Run mode (no WFI) to reduce power consumption if CKAF\_SEL is set and CK\_AF is present.

### 3.6.1.3 Low Power with Frequency Slow Down

When the PLL has been frozen by a WFI instruction you need a delay after the interrupt to wait for the PLL to lock. To avoid this delay but not to lose the Low Power consumption, you have two choices which are:

- To use a WFI instruction with LPOWFI reset and initialize INTCLK to CLOCK2 with XT\_DIV16 bit set (CSU\_CKSEL register). When the WFI occurs, CPUCLK is stopped and INTCLK doesn't change.



- To not use the WFI instruction. Set XT\_DIV16 bit of CSU\_CKSEL register. Initialize DX2:0 of PLLCONF to 6 to divide the PLL output clock by 7 which is the maximum. Initialize the CPUCLK clock prescaler to 7 to divide INTCLK by 8.

### 3.6.2 Reset and Stop Manager

RESET normally means restarting from the beginning with everything initialized. However sometimes it's necessary to know the context of the ST9+ before the RESET and if it was an external or internal RESET. Two bits, SOFTRES and WDGRES in the CLK\_FLAG register indicate the previous context. Table 3. shows the three cases to manage.

**Table 3. Three Types of RESET**

RESET Type	SOFTRES bit	WDGRES bit	Meaning
External RESET	0	0	High to low level on RESET pin.
Watchdog RESET	0	1	The Watchdog Timer is activated and the Timer has reached 0.
Software RESET	1	0	The HALT instruction is executed, waiting for an external Reset to restart (if the SRESEN bit in the CLKCTL register is set).

These bits are read-only and change with each Reset.

## 4 USING THE ON-CHIP PERIPHERALS

This chapter introduces the main peripherals of the ST9+ family. Each variant includes none, one or several peripherals of each type. This allows you to select the variant that best fits your requirements. For high-volume markets, you can order custom versions with exactly the type and number of peripherals required, including the relatively exotic ones not described here but available on request, such as videotext decoders etc.

### 4.1 PROGRAMMING THE CORE AND PERIPHERALS

In addition to describing how each peripheral works, we give examples of the code needed to use them in several configurations. This code is available on the Companion software. You can experiment with the original code or modify it to do the functions you require.

Configuring and using the core and the peripherals involves a considerable amount of bit manipulation in the registers. Many variables that drive microcontroller states are Boolean values. To reduce the use of addressable space in registers, bits have been logically grouped in bytes, so the majority of the control registers have their eight bits fully used.

To properly program these registers, you need to track the exact position of each bit in each register. You can do this by referring systematically to the appropriate Data Sheet, and commenting the source text so that it can be easily read and understood later. See the following example:

```

ld      R235, #111100000B ; R235 is register MODER
;      | | | | | | | +--- HIMP : no foreign access to bus
;      | | | | | | | +--- BRQEN : no foreign access to bus
;      | | | + + + + --- PRS2, 1, 0 : processor at full speed
;      | | + + + + + + + DIV2 : crystal frequency divided by 2
;      | + + + + + + + + USP : user stack pointer in registers
;      + + + + + + + + SSP : system stack pointer in registers

spp     #0                ; SPI page
ld      R254, #10000001B
;      | | | | | | | +--- SPR0 : SPR1, SPR0 = 01: clock divided by 16
;      | | | | | | | +--- SPR1 :
;      | | | | | + + + + CPHA : Input sampled on rising edge
;      | | | | + + + + + CPOL : Rest level of serial clock = 0
;      | | | + + + + + + BUSY : Set to ready
;      | | + + + + + + + ARB : No I2C arbitration
;      | + + + + + + + + BMS : SPI used as a shift register (not I2C)
;      + + + + + + + + SPEN : SPI enabled

```

This style has the advantage of clarity. However, there is still a problem that it does not address: the variety of the different products of the ST9+ family.

The different products available in the ST9+ family are very diverse and as a result it is not always the case for all products that a given function is performed by the same bit of the same register. The location of a register in one peripheral may be different in another. To avoid this problem, the GNU9 programming tool chain provides a set of include files that define the physical location of every bit and register, by their symbolic name. These files correspond to the appropriate variant of the ST9+. Using them guarantees that switching to another member of the family will not need more than changing the Include statement at the beginning of the source text. The same example as above, using the predefined symbols reads as follows:

```

.include "system.inc" ; System register

ld      MODER, #MOM_sspm+MOM_uspm+MOM_div2m; Both stacks in
;      ; registers, clock divided by 2

spp     #SPI_PG        ; SPI page

ld      SPICR, #SPm_spen+SPm_SP_16 ; Enable SPI, 1st clock
;      ; configuration, Clock/16

```

This notation is more compact, and is independent of changes either between variants in the same family, or by changes made globally to the family in the future. This writing style is recommended for this reason.

## 4.2 PARALLEL I/O

The parallel input-outputs have a basically very straightforward functionality. Once initialized, they appear as a register that can be written or read. However in many cases, direct byte-wide input-output is not sufficient. Bit-oriented I/O is often what is used in microcontroller systems. A powerful feature of the ST9+ is that you can address the eight bits of each port individually. The ST9+, like most microcontrollers also provides the external pins of the other peripherals (timers, UARTs, etc.) by diverting some bits from the parallel I/O ports.

The ST9+ parallel I/O has an additional very flexible feature. You can independently configure each bit as:

- An input with two variants (TTL or CMOS levels)
- An output with also two variants (open-drain or push-pull)
- A bi-directional port with either a weak pull-up or an open-drain output side
- An alternate function output (that is, the output pin of an internal peripheral), with also either open-drain or push-pull output driver.
- Analog Input (see note)

**Note:** On the port that accommodates the inputs of the Analog to Digital Converter, there is a special feature. In all other peripherals that require an input, you only need to configure the corresponding pin as an input. However, when using the ADC you can put the input pins to any voltage level from ground to  $V_{cc}$ . This is normally badly handled by standard logic gates that dissipate considerable power when the voltage reaches the limit range. To avoid this, the port that provides the input pins of the ADC has a special Alternate Function mode. Unlike the other ports it is used for input. This mode disconnects the input buffer from the pin and shorts the buffer input to the ground. The output buffer is put in high-impedance mode. The pin is permanently connected to the input of the ADC, thus allowing its voltage to be read at any time.

To handle all these capabilities, each port requires three configuration registers, PxC1, PxC2 and PxC3, where x is the port number. Once configured, a port exchanges data with the core through the PxDR data register.

The configuration registers are placed in various pages of the register group 15, as well as the data registers, except for the first six ports. These six belong to the system register group (group 14) for easy access.

Some ports also include DMA capability, configurable to work with the Multi-Function Timer.

### 4.3 STANDARD AND WATCHDOG TIMERS

You can use this timer both as a regular timer and as a watchdog timer.

#### 4.3.1 Description

The block diagram of the Watchdog Timer is the following:

**Figure 25. Watchdog Timer Simplified Block Diagram**

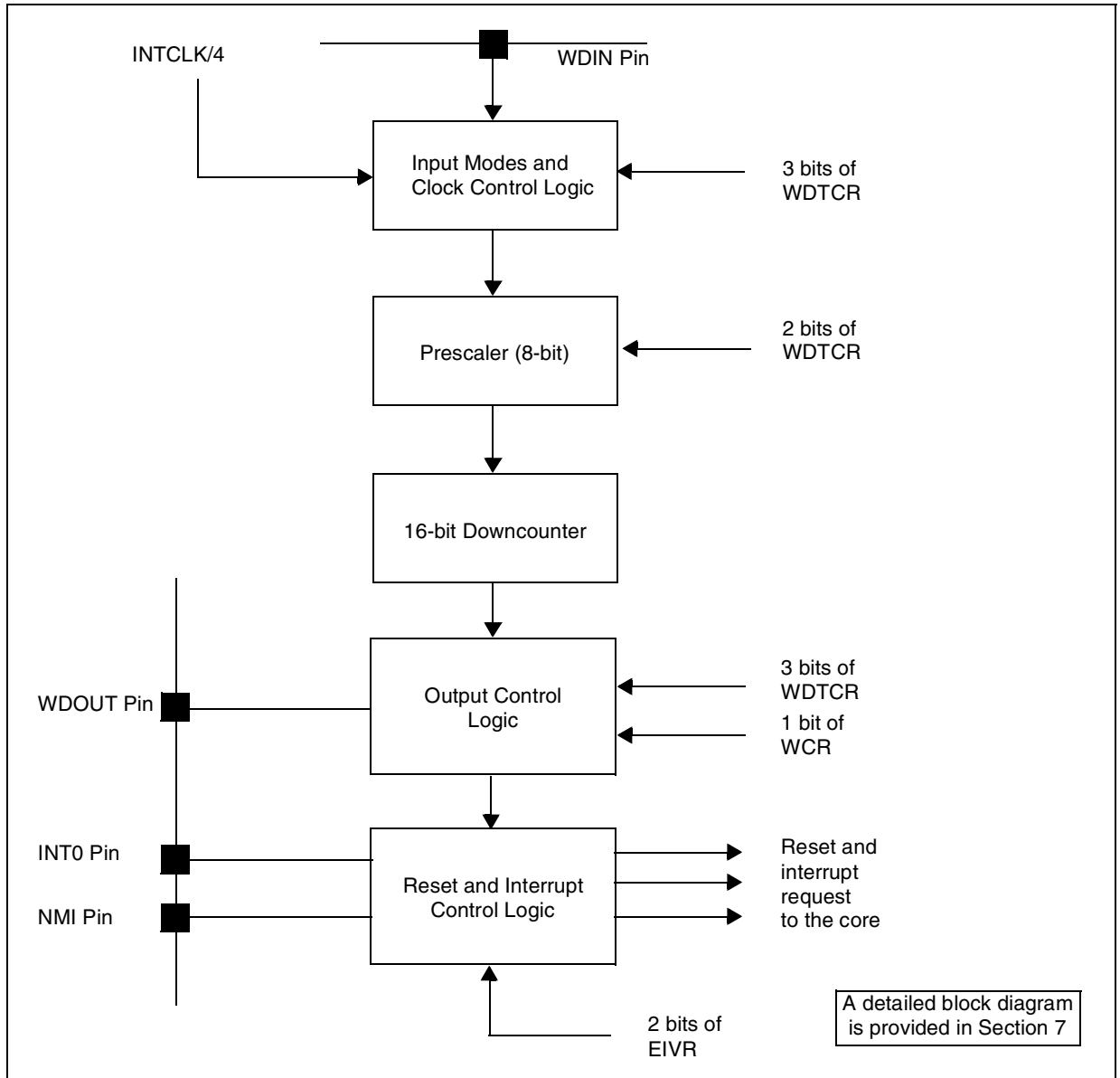

In Counter/Timer mode, the WDT can count pulses coming either from an input pin (WDIN; in the ST90158, alternate function of P7.0) or from the internal clock divided by 4. When the internal clock is used, the external pin, if enabled, can either gate the clock, start the counter, or

reload it with its initial value. You select these modes using three bits in the WDT Control Register, as follows:

INEN	INMD1	INMD2	Mode
1	0	0	Event counter mode_
1	0	1	Gated mode
1	1	1	Retriggerable input mode
1	1	0	Triggerable input mode
0	X	X	Input section disabled. Internal clock selected.

#### 4.3.1.1 Event Counter Mode

The counter value is decremented at each falling edge on the WDTIN pin if ST\_SP is high (bit 7 of WDTCR).

**Figure 26. Timer in Event Counter Mode**

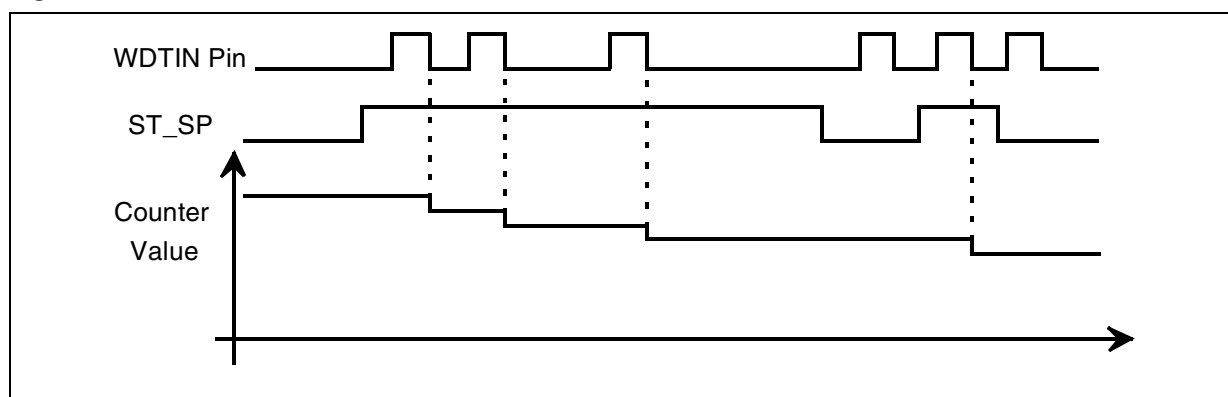

#### 4.3.1.2 Gated Input Mode

The counter value is decremented by WDTCLK (INTCLK / 4) if the WDTIN pin and ST\_SP are high.

**Figure 27. Timer in Gated Input Mode**

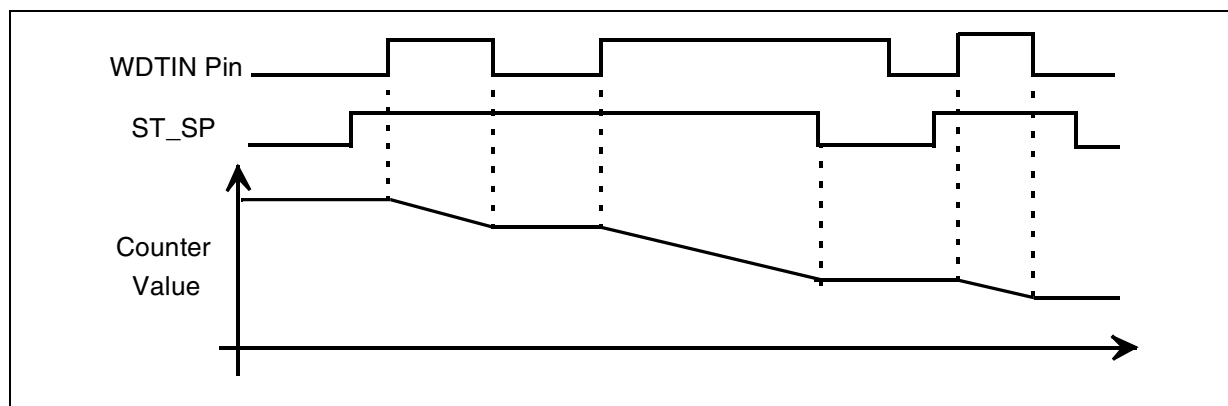

### 4.3.1.3 Retriggerable Input Mode

The counter value is decremented by WDTCLK (INTCLK / 4) if ST\_SP is high.

The initial value is reloaded either at the rising edge of ST\_SP or at each falling edge of the WDTIN pin if ST\_SP is high.

Figure 28. Timer in Retriggerable Input Mode

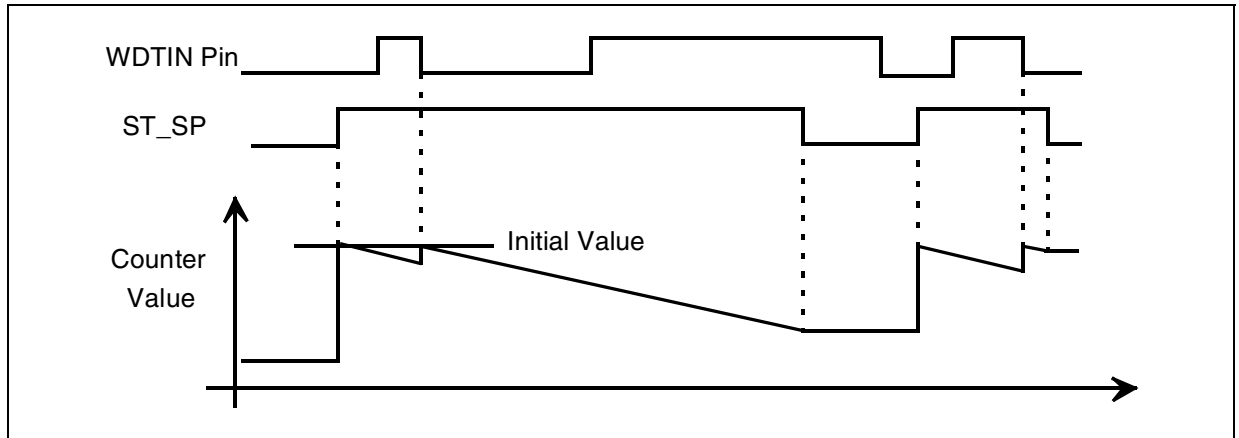

### 4.3.1.4 Triggerable Input Mode

The counter value is decremented by WDTCLK (INTCLK / 4) if ST\_SP is high and falling edge of WDTIN occurs.

The initial value is reloaded at the first falling edge of the WDTIN pin if ST\_SP is high.

Figure 29. Timer in Triggerable Input Mode

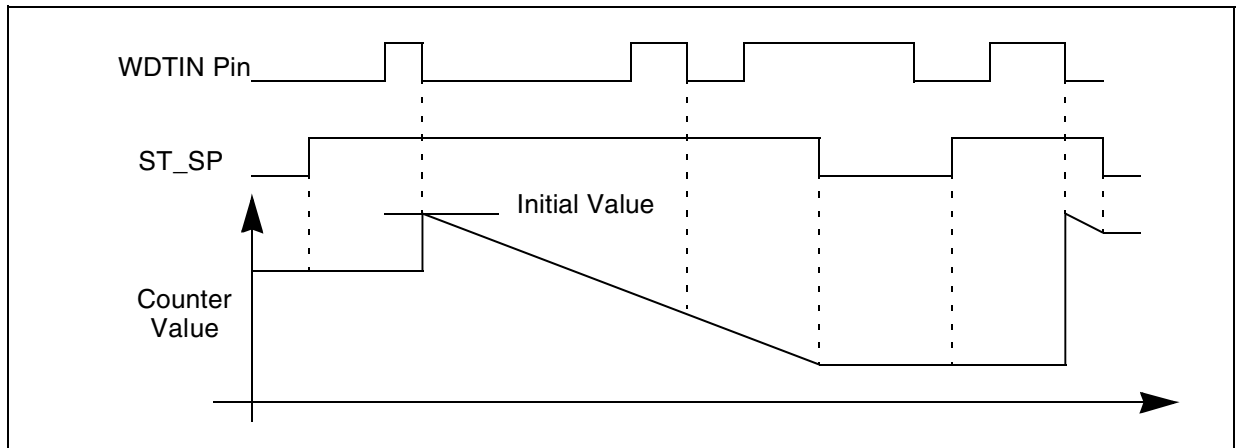

### 4.3.1.5 Single/Continuous Mode

On counter underflow (End Of Count), the counter is always reloaded with the value of the latch that is actually accessed when writing to the WDTLR and WDTLR register pair.

The counter has two modes: Single-shot or Continuous, selected by the S\_C bit of WDTCR. In Single-shot mode, the End Of Count also resets the ST\_SP bit of the WDTCR, which stops the counter after one cycle. In Continuous mode on reaching the End Of Count condition, the counter reloads the constant and restarts. When the ST\_SP bit is set, the contents of the latch are written again to the counter, allowing the initial count value to be changed before starting the counter.

You restart the down counter by setting the ST\_SP bit. The constant value can be either the initial value or a new one as shown on the following diagram:

**Figure 30. Timer in Single Mode**

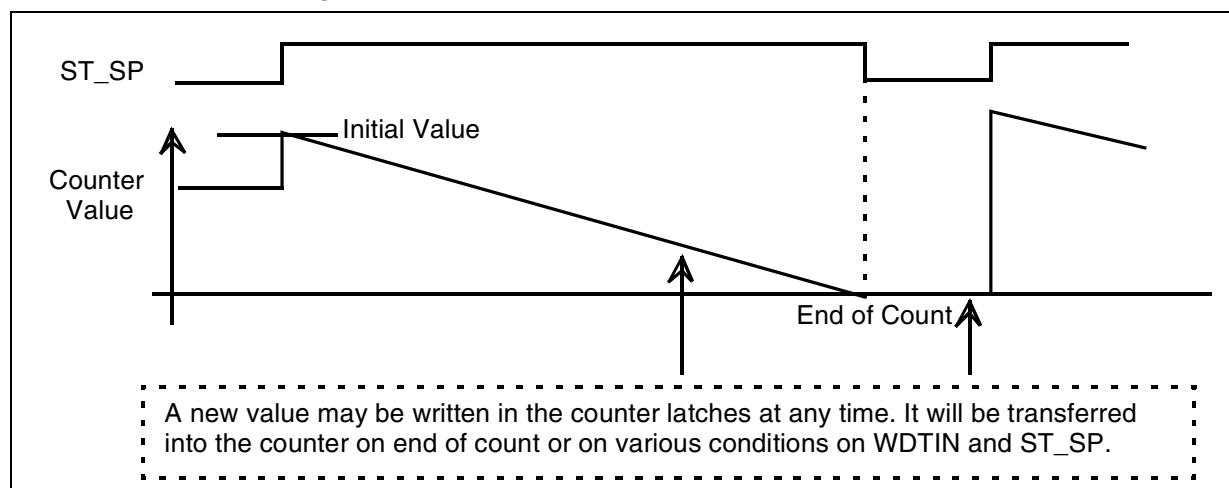

#### 4.3.1.6 Output Pin

Another pin, WDOUT (alternate function of P8.4 for ST90158), when enabled by the OUTEN bit, can change its state in two ways on the end of count of the main counter. Basically, each time the counter overflows, it updates the output value. This can produce two different effects, selected by the OUTMD bit: either the state of the WROUT bit is copied to the output at that time, or the output is complemented.

Figure 31. Output Pin Block Diagram

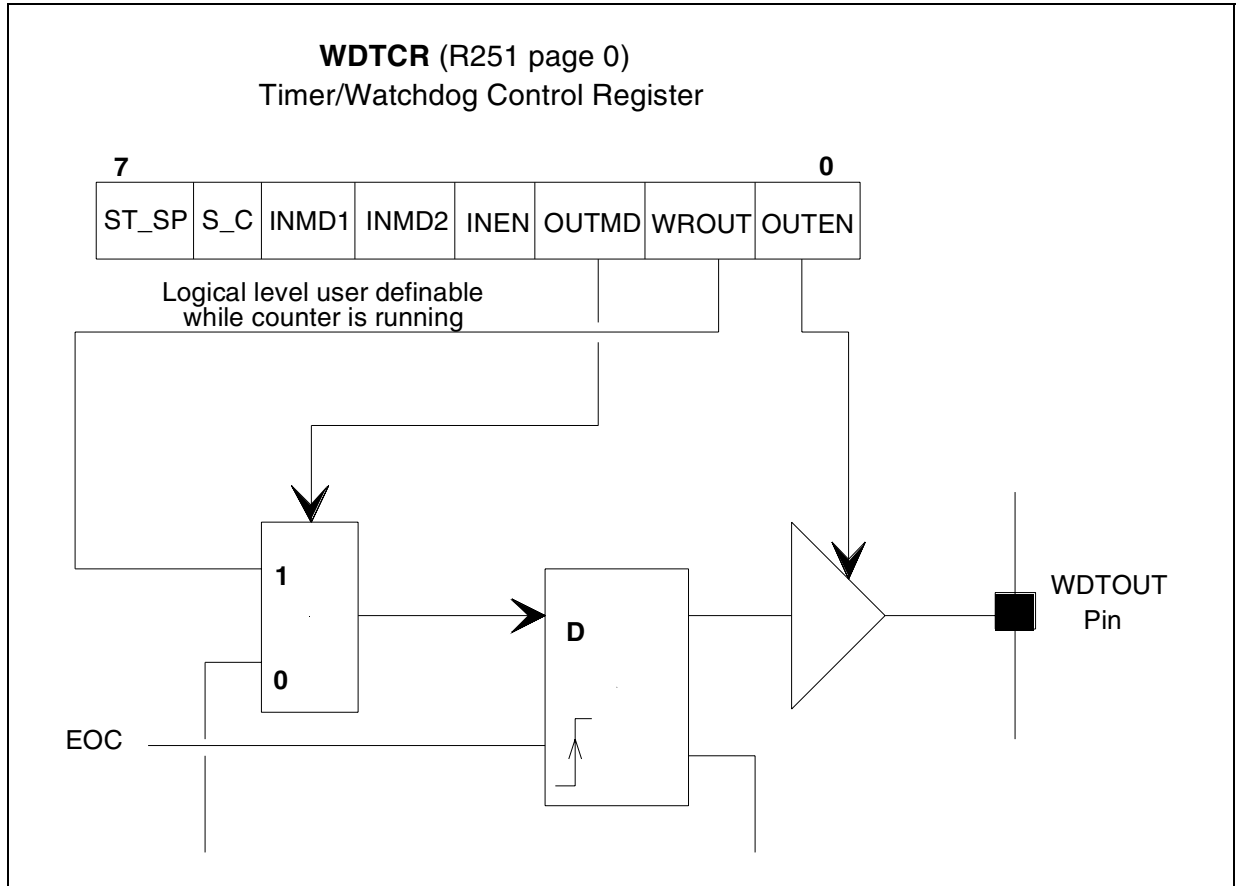

### 4.3.2 Timer Application for Periodic Interrupts

In this application, the clock is internal and the input and output pins are unused. The counter is set to Continuous mode, and the value of the reload registers chosen so that the overflow occurs exactly every 128 microseconds.

#### 4.3.2.1 Initialisation of the WDT for a Periodic Interrupt

Very few registers are involved when you use the WDT for this purpose, since there is no input apart from the internal clock and no output. However, the WDT interrupt handling is a little different from most other peripherals in that it borrows the interrupt circuit named INTA0 that is normally assigned to external interrupt pin INT0. So you configure the WDT in two steps: initializing the WDT itself, and also the external interrupt INTA0.

In this example application, the internal frequency is 24 MHz and the interrupt rate must be 8192 Hz. The timer starts with the preset count on the low-to-high transition of the ST\_SP bit of the WDT Control Register.

The initialisation routine for the WDT is then:



```

/* ***** Configure Watchdog for Periodic Interrupt ***** */
void ConfigWDT ( void )
{
  SelectPage( WDT_PG )      ; /* select Watchdog page */
  WDTPR = 0 ; /* 122 us = 366 ticks */
  WDTR = 365 ; /* preset is nb ticks-1 (WDTR is the pair WDTLR and WDTNR) */
  WDTCR = (WDTm_stsp) ; /* WDT is set to continuous mode, no inputs, no
  outputs */
  /* Interrupt must be connected to intA0 in the EIVR register */
}

```

The initialisation routine for INTA0 follows. In this example application, interrupt A0 is the only "external" interrupt enabled, and it is assigned priority level 2:

```

/* ***** Initialise Interrupt A0 and Current Level ***** */
void ConfigInterrupts ( void )
{
  SelectPage( EXINT_PG ) ;
  EIVR = (EIm_tlism+(unsigned char)INTA0VECT) ; /* int. A0 is generated
  on WDT overflow */
  EIPLR = 1 ; /* intr A0 (and that of same group) with high priority */
  EIMR = EIm_ia0m ; /* intr A0 alone enabled */
  CICR = (Im_gcenm+Im_iamm+Im_ienm)+7 ;
  /* current processing level: minimum ; int. enabled, nested mode */
  /* This starts also the MFT */
}

```

### 4.3.3 Watchdog Application 1: Generating a PWM

This application provides a PWM with a programmable duty cycle. You can use it as an application exercise for learning to use the programming and debugging tools since it is very simple. The only hardware required to watch the effect of the program is a LED in series with a resistor connected between P4.4 and Vcc (anode towards Vcc). You will find the application in the Companion software in the WDT/appli1 directory.

The WDT can only provide a delay after which the output may change its state, and an interrupt is triggered. The principle of using the WDT as a rectangular signal generator is to set it to Continuous mode, to load it with a time value, and let it count down until zero. The control register is set so that an interrupt is then generated, and the output pin is updated at the same time. The interrupt service routine will reload with the other value, and preset the WROUT bit to the complement of the current value, so that the opposite state will be transferred to the

output pin at the next end of count. By alternating between two time values, a duty cycle other than 50% can be obtained (PWM). When the interrupt occurs, the output has already changed its state, so that the waveform can be very precise since it depends only on the timer hardware and not on the software. All that the interrupt service routine has to do is to load the timer latch with the value to be used when the end of count is reached. Thus, the constraint is that the reload interrupt must be guaranteed a latency time less than the shortest time between two output transitions. This may or may not be difficult to realize according to the intended timing and the presence of portions of the program where the interrupts are disabled. It is thus recommended to properly manage the interrupts and thoroughly use the priorities to achieve this requirement.

The WDT does not have an interrupt cause and a vector of its own. It must borrow them either from the Top Level Interrupt or the INTA0 input. We have chosen to use INTA0 here, and to give it a priority of 6 which is high, but not the highest (which is 0).

#### **4.3.4 Watchdog Application 2: Using the Watchdog**

A watchdog timer is a safety measure to prevent a program going adrift. It relies on a hardware timer that must be periodically reset by the program. Failing to do this will reset the whole program (at the End Of Count). You will find it in the Companion software in the WDT/appli2 directory.

The efficiency of this approach varies with the type of program and depends on the following conditions:

The hardware action to perform in order to reset the timer must be so complex that if the processor goes adrift, it cannot accidentally reset the watchdog. In the ST9+, you need to write 0AAh and 055h successively to the WDTLR.

The chosen time-out value must be greater than the interval at which the program resets the watchdog. It must also be as close as possible to that interval for maximum safety. Since the watchdog time-out value is set once at the beginning of the program, this condition is best fulfilled if the resetting action is performed at constant intervals.

A special software arrangement must be designed to reduce the chance that the part of the program that resets the watchdog can continue undisturbed when other parts of the program are faulty. This may include an interlock mechanism that requires that several program branches be executed to enable the resetting of the Watchdog count.

As you can see, achieving a very secure program malfunction detection by the sole means of a watchdog is a very difficult thing to realize. However, the watchdog can still play a key role in the safety of some systems, an example of which is an induction motor controller.

## 4.4 MULTIFUNCTION TIMER

This device is the most powerful of the ST9+ on-chip peripherals. This description only covers its main features. You can study the more intricate details with the help of an ST9+ Datasheet.

The Multifunction Timer can handle many different operating modes; so many in fact, that virtually the only limit is your imagination. Let's first have a look at the general organization.

The first diagram in Figure 32 represents the inputs and outputs, the prescaler register and the clock selection blocks, with their associated configuration registers.

Figure 32. MFT Input/Output Modes

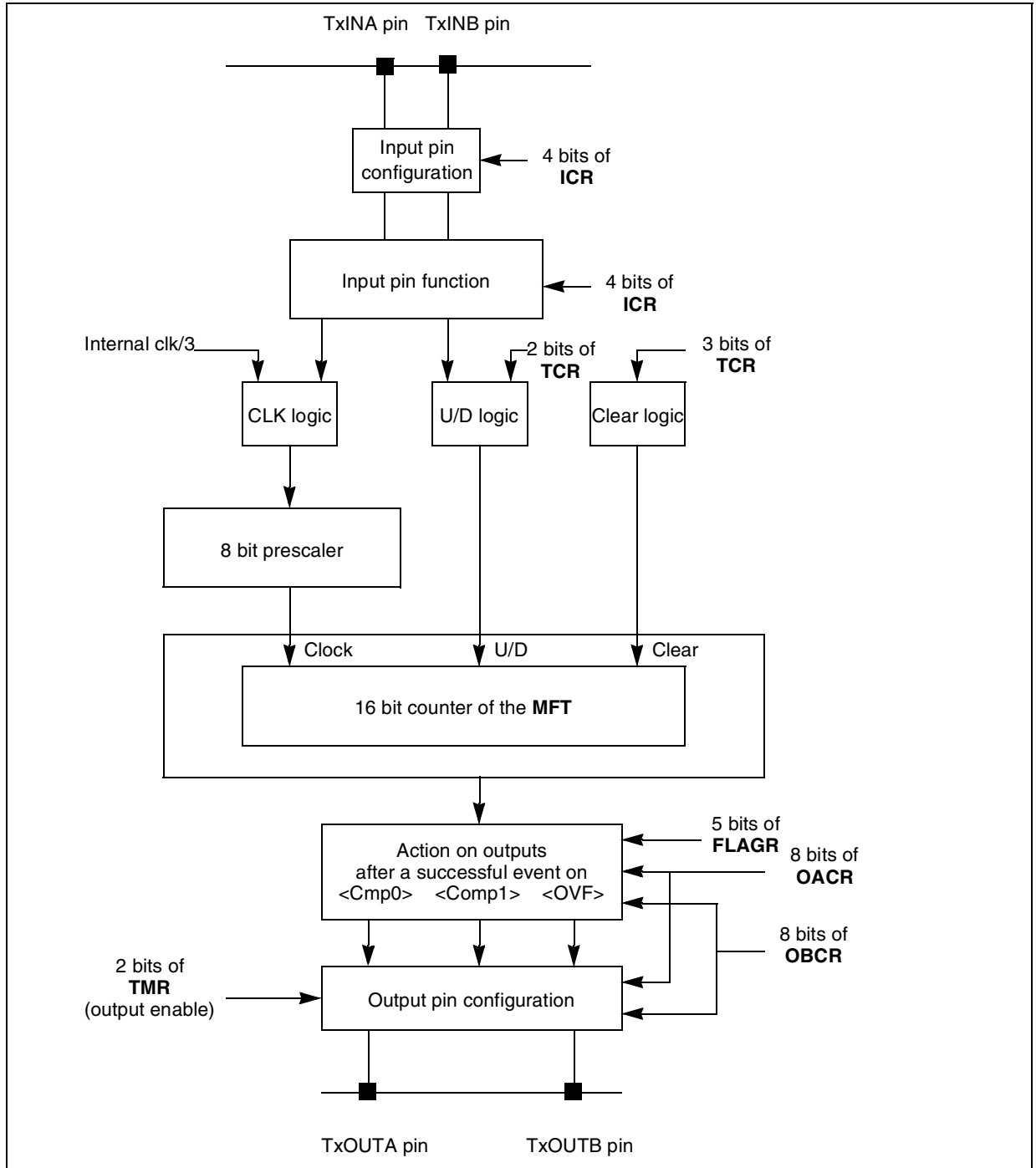

The two outputs are actually the Q outputs of a flip-flop which set and reset. Flip-flop inputs can be individually configured to receive pulses from either of the following events: compare with CM0, compare with CM1, and overflow/underflow. This is used to generate single-shot or periodic wave forms simply by using the timer.

In addition to providing output signals, the timers can generate so-called "internal events" that can be used to synchronize other internal peripherals such as the DMA and the Analog to Digital Converter. Not all peripherals to be synchronized can be connected to just any MFT. For each ST9+ variant, the connection between each MFT and the other peripheral is unique. Refer to the corresponding datasheet for more information.

The second block diagram represents the counter, the capture and compare registers, the reload logic and the associated configuration and status registers. The interrupt and DMA blocks are not represented.

**Figure 33. MFT Simplified Block Diagram**

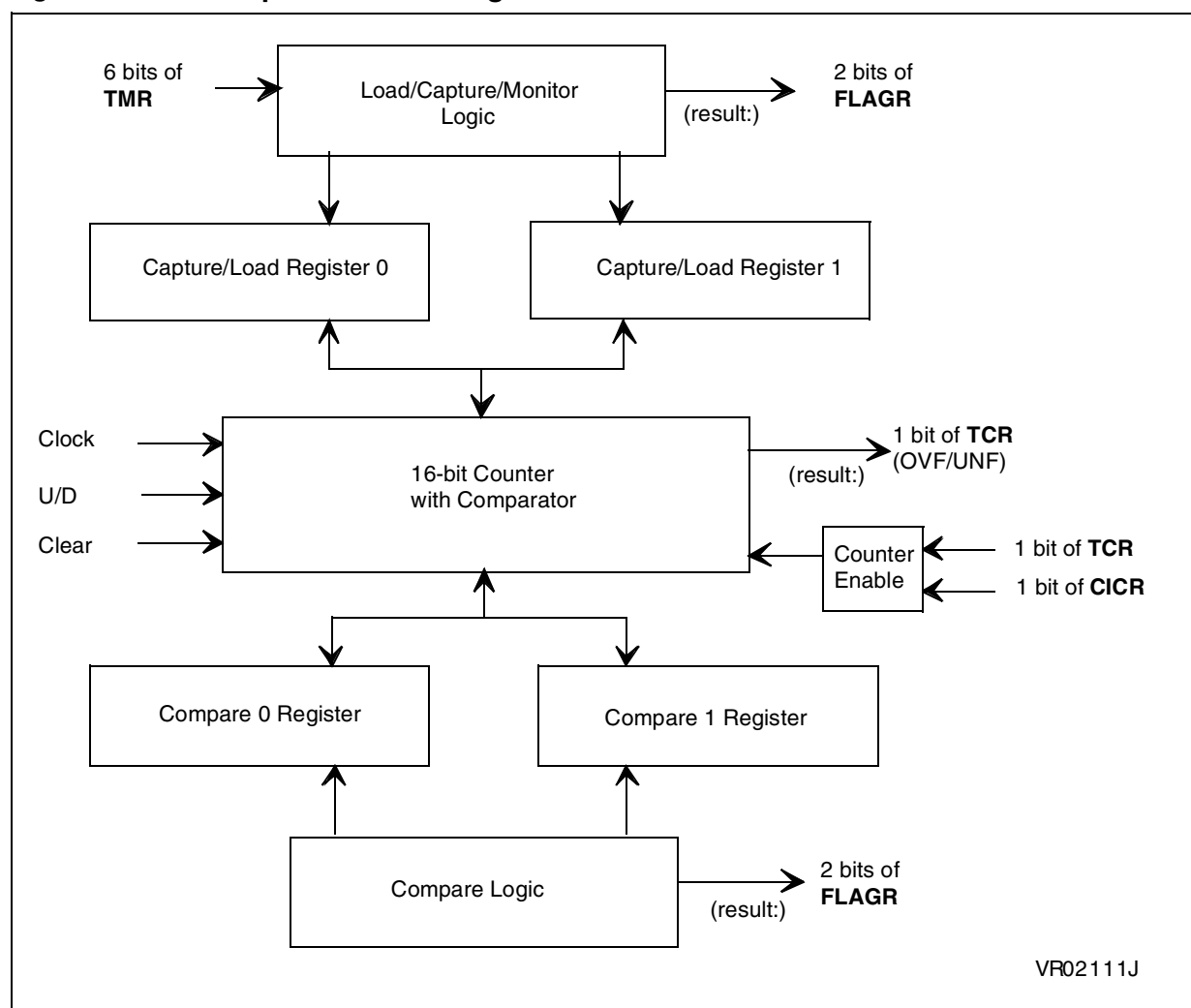

In the above diagrams, the interrupt and DMA logic are not represented. They obey the general interrupt and DMA rules described earlier, and are controlled by three registers.

The Interrupt Vector Register controls the location of the interrupt vectors in program memory. They must be located at addresses that are multiples of 8.

**Figure 34. MFT Interrupt Vector Register**

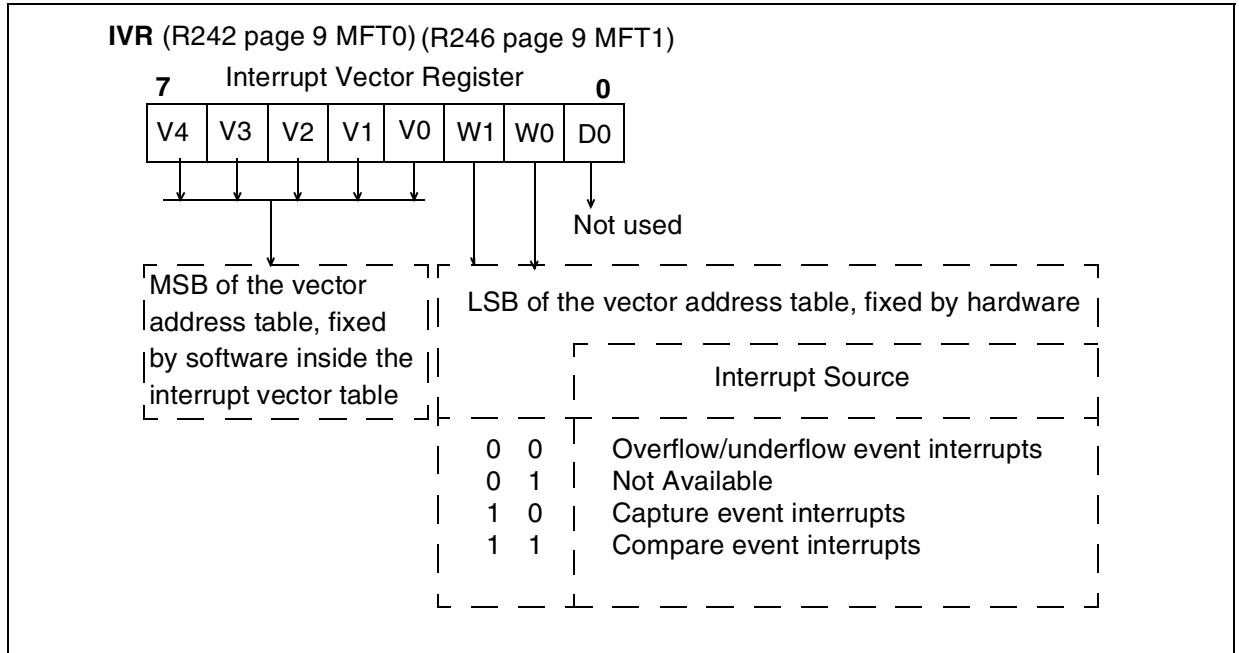

The Interrupt and DMA Mask Register individually enable and disable the various interrupt and DMA sources.

**Figure 35. MFT Interrupt and DMA Mask Register**

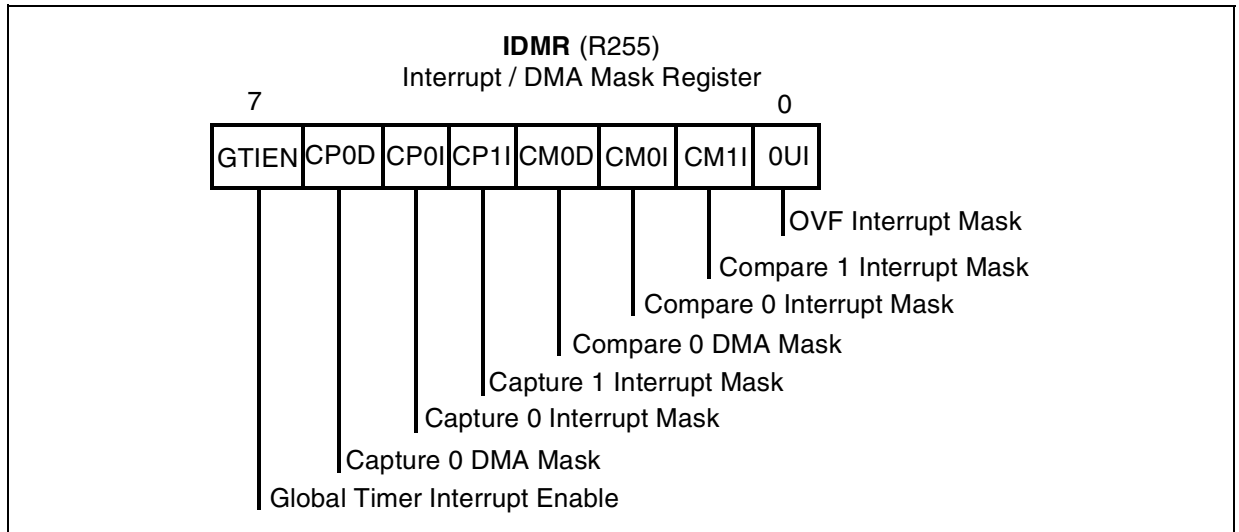

The upper five bits of the Interrupt and DMA Control Register indicate the status of the interrupts and the DMA blocks. The lower three bits set the Interrupt and DMA priority level.

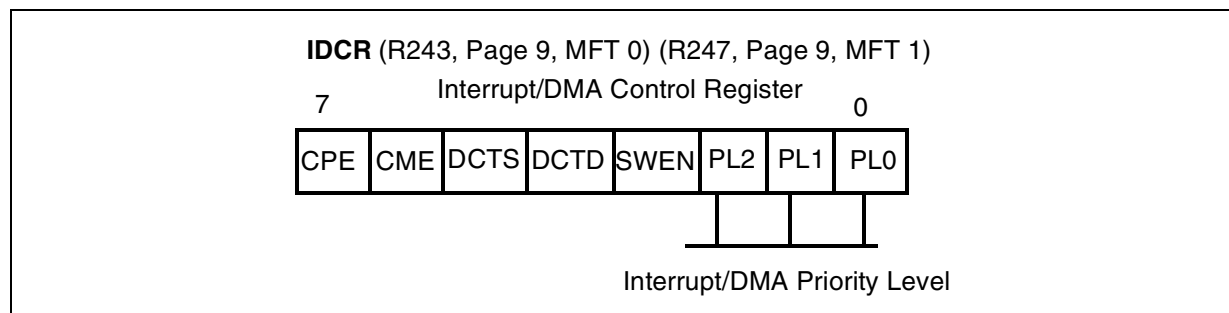
**Figure 36. MFT Interrupt and DMA Control Register**

The Input and Output Control Register has only two active bits. They are used to internally connect the Output A of each MFT to its own Input A. One bit does this connection for all even-numbered MFTs, and the other for all odd-numbered MFTs.

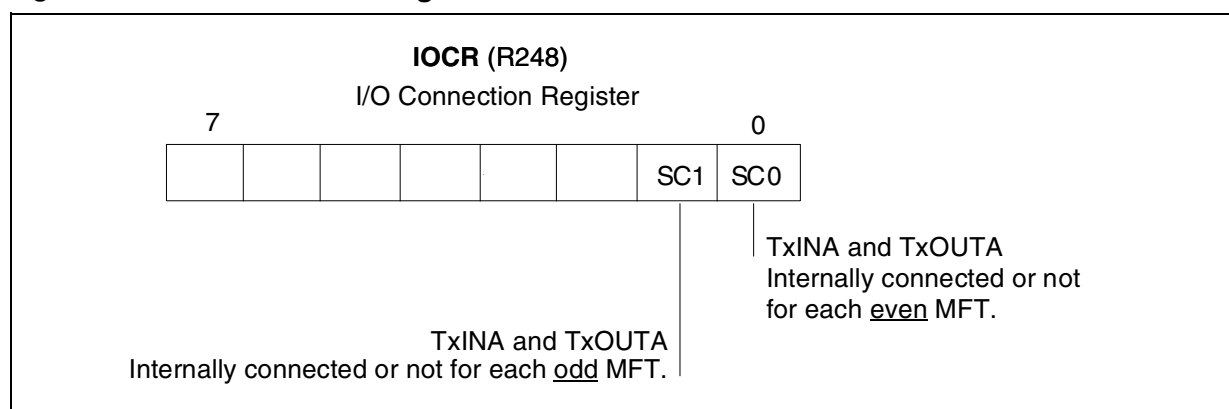
**Figure 37. MFT I/O Control Register**

#### 4.4.1 Generating Two Pulse Width Modulated Waves with One MFT

##### 4.4.1.1 Description Example

The Multifunction Timer is used here as a double pulse-width modulator. It is also possible to have a single PWM output if needed. Let's look at a simplified block diagram of the MFT showing only the functional blocks that are actually used. See Figure 38.

This is possible using the two comparators that simultaneously compare each capture register with the free-running counter. When the counter overflows, it is reloaded with the contents of the Load Register 0. At that time, both outputs are reset.

When the value of the counter becomes equal to one of the compare registers, a pulse is sent to the output flip-flop of the corresponding side, thus setting the output. So the low time is the time between the counter overflow and the comparison. The high time is the remainder of the period.

Figure 38. MFT Block Diagram

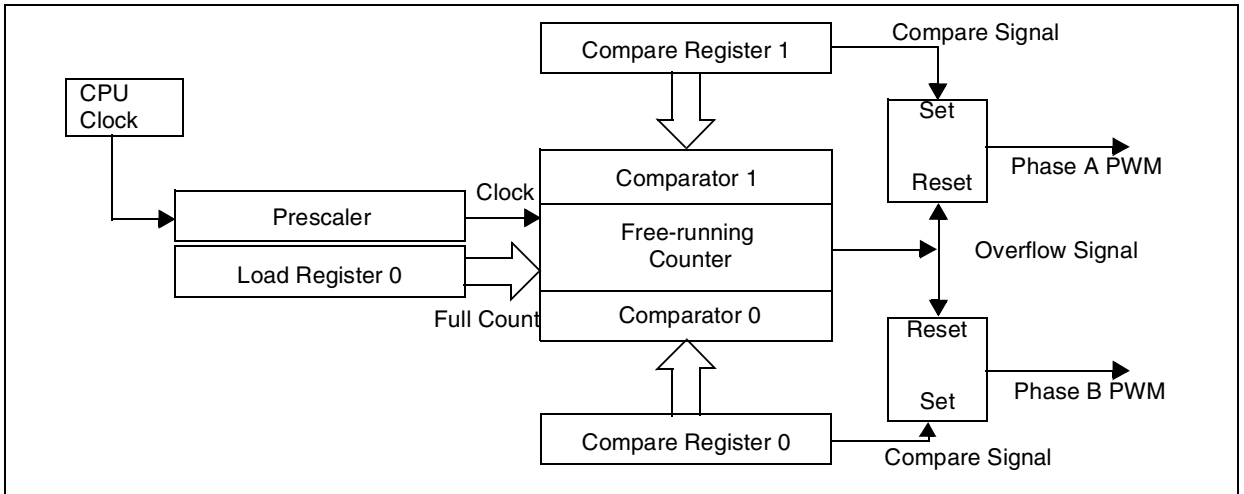
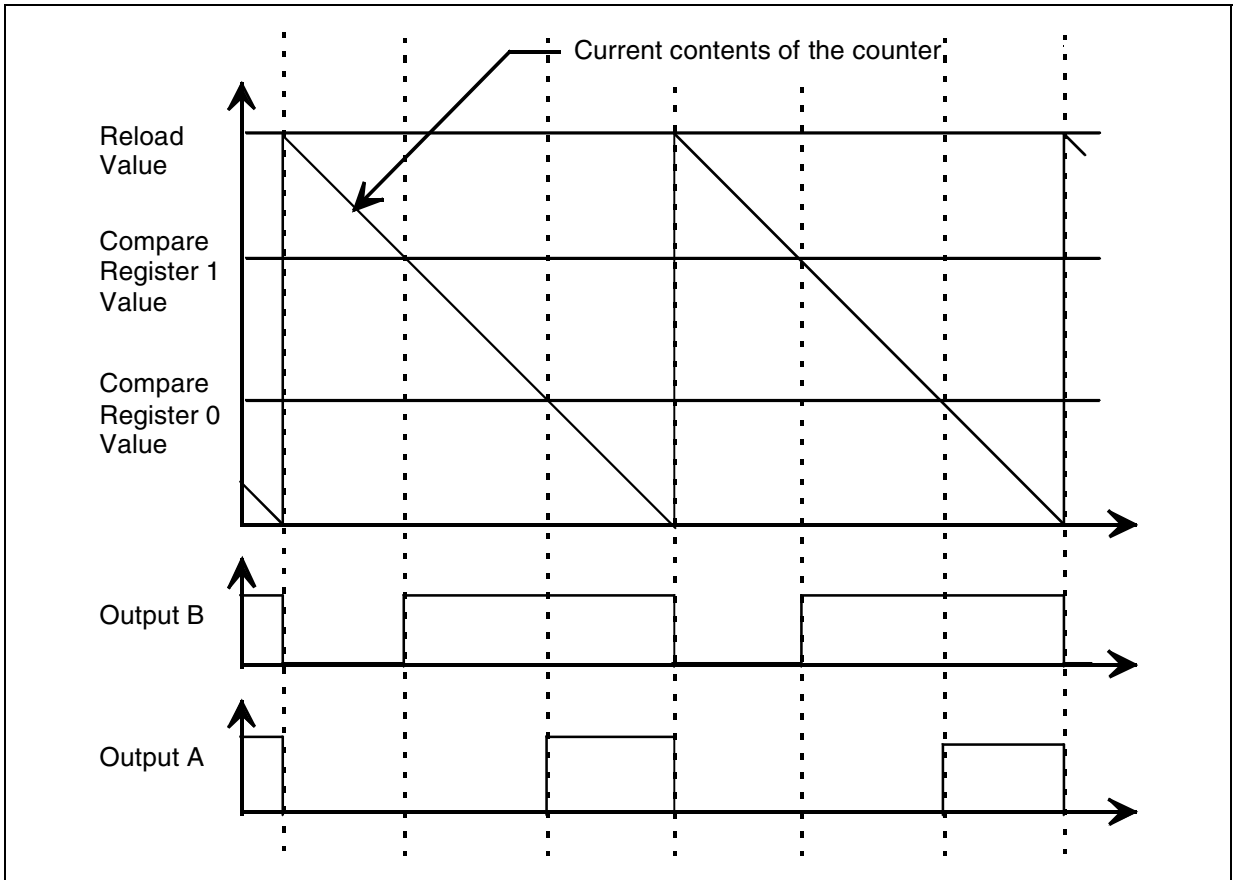

Figure 39. Using a Counter and 2 Compare Registers to Modulate 2 Pulse Widths



Actually, as nearly everything is configurable by values in control registers, this is only one of the ways to do it. In particular, the direction of the counter (upward or downward) and the effect of the actions on the outputs (set/reset) can be chosen at will.



This value of the Load Register determines the frequency of the output signals. For example, with a reload value of 255 and a 25 Mhz internal clock, the PWM frequency is  $1/256$  of the 25 MHz clock divided by 3, that is 32,552 kHz. In this case, the range of the compare registers is 1 to 255 inclusive. A value of 0 locks the outputs to the high state.

To use the timer to deliver variable PWM, we need to change the value of the compare registers from time to time. The simple way that first comes to mind is to write into the compare register whenever we need to update the PWM rate. This can lead to problems.

If we write the new value into the compare register while the counter value matches the previous contents, this can make the comparison fail and the pulse that changes the state of the output is not produced. The result is the output signal misses one cycle, as follows:

**Figure 40. Compare Register is modified while its Content matches Counter**

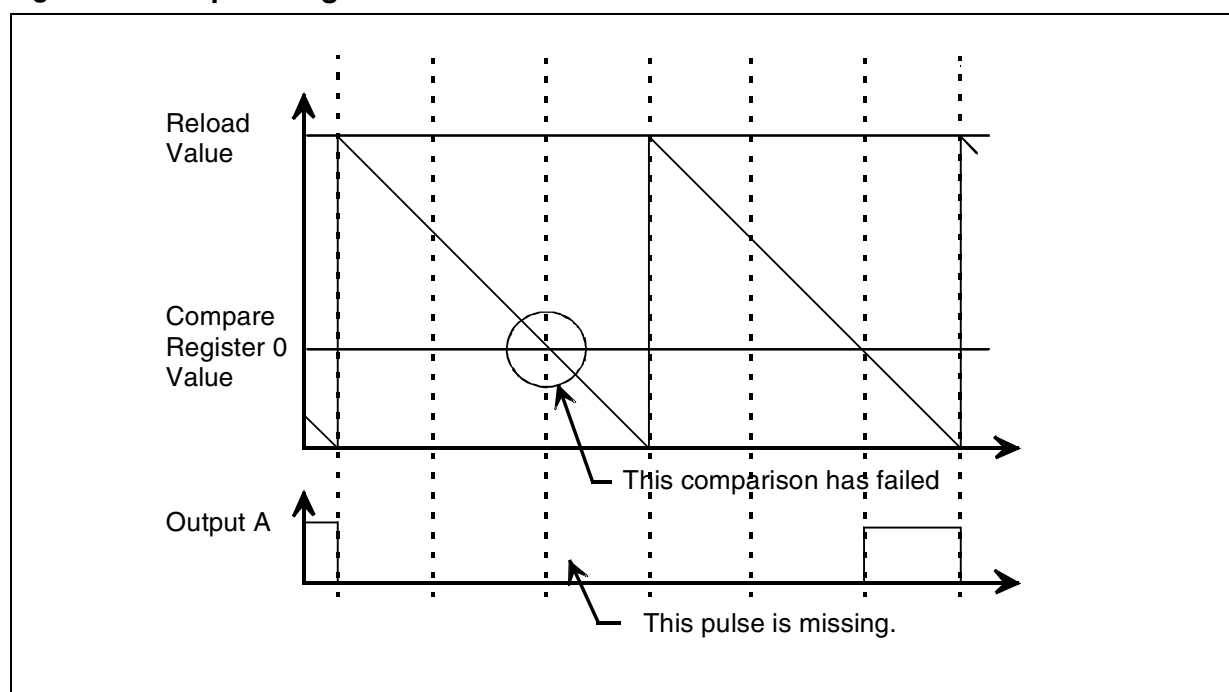

This will obviously have a bad effect on the electronic circuit connected to this output.

Another problem can occur if the reload value exceeds 255. Then, two bytes are needed to express the compare values. Since the ST9+ is an 8-bit machine, the two bytes that make up the word are sent one after the other. If the high bytes of the old and new values are the same, there is no problem. But if they differ, there are three possibilities for the value in the compare register:

- The register contains the old value
- The register contains one byte of the old value, and the other byte of the new value
- The register contains the new value

Depending on the relative values of the old and new values, on the order of writing the bytes (high byte first, or low byte first), and on the direction of the timer (up-counting or down-counting), various things may happen. These can range from a missed comparison (see Figure 40) to two comparisons in the same cycle (not a problem).

This indicates that you have to pay attention to the time at which the compare register has to be updated. If we consider that the duty cycle does not vary widely from one cycle to another, the safest time to change value is as soon as possible after the match. The best way to do it is to store the new value in a variable (a register is a good choice), and configure the MFT to trigger an interrupt when the match occurs. Then, the interrupt service routine is executed and the new value is safely copied into the compare register.

#### 4.4.2 Generating a Pulse Width Modulated Wave with a Cleaner Spectrum

The use of a MFT to produce two PWM signals is convenient, especially for example in a stepper motor application. There, an ST90158 is used and only one MFT is available for PWM generation, since the other one is used for other purposes. However, this method suffers from a parasitic phase modulation of the signal since the falling edge is fixed, and the rising edge moves with the desired duty cycle. This leads to the production of unwanted harmonics in the resulting spectrum. This is not a problem for a lot of applications.

Sometime these harmonics are prohibited. Example: when we want to drive a high power induction motor, these harmonics have two serious drawbacks:

- They produce parasitic frequencies that are injected in the mains, which is not allowed by power distribution companies,
- They feed the induction motor with even ranked harmonics, which degrade the efficiency of the motor and reduce the peak output power.

You can improve this situation by using a symmetrical PWM generation, producing waveforms as follows:

**Figure 41. Symmetrical PWM Waveforms**

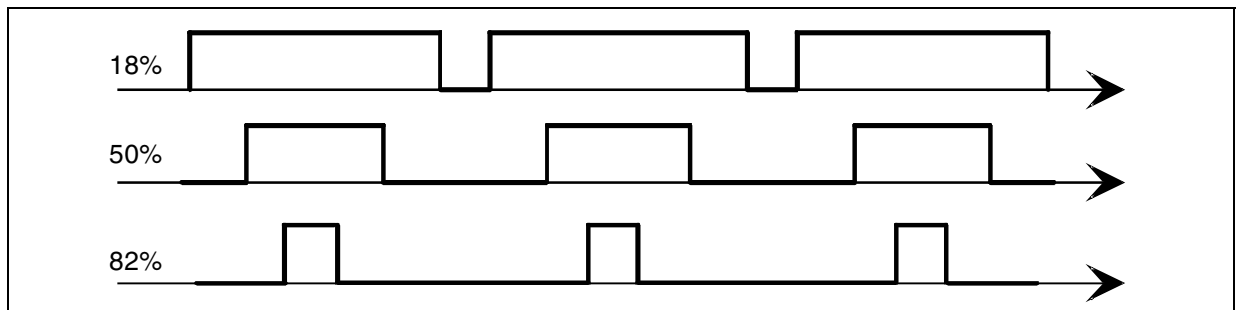

You use the MFT in the following way. One MFT being used for one output signal, you use only output A. You configure it so that it is set on a comparison with compare register 1, and reset on a comparison with compare register 0. These registers are always loaded with values

that are symmetrically centred on half of the reload value. For example, if the reload value is 255, the compare registers are set to the following values:

Duty Cycle	Compare Register 0	Compare Register 1
10%	115	140
25%	96	159
50%	64	191
75%	32	223
90%	13	242

You need to ensure that the compare registers are not written while they are used for a comparison. Because of this, they are written in an interrupt service routine that is triggered by the MFT itself. To allow maximum latency time, the interrupt is triggered either by a compare 0 or a compare 1 event, according to the value of the duty cycle. For duty cycles between 0 and 50%, the compare 0 event is used. Between 50% and 100%, the compare 1 event is used. The following figures shows the timing diagram.

**Figure 42. Output A Timing**

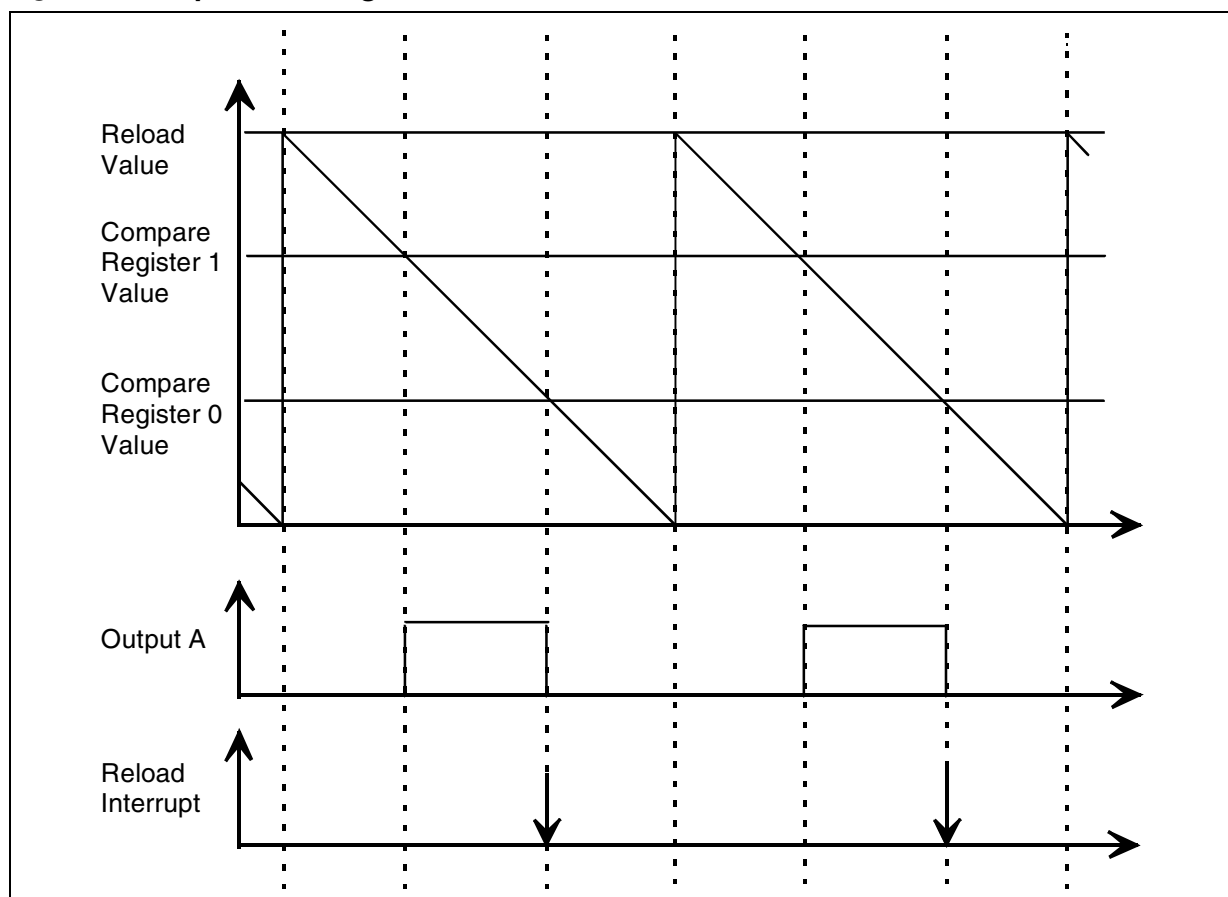

### **4.4.3 Incremental Encoder Counter**

An incremental encoder is a device that generates two square signals in quadrature when its shaft rotates. Its main specification is the number of cycles per revolution, i.e. the number of square signal cycles for one shaft revolution. The greater the number of cycles, the more accurate it is, and the more it costs.

In a stepper motor application, it is used to monitor the rotation of the motor. Here however, we have taken an encoder that has a great resolution, and this section will show you how to use an MFT to count encoder pulses, and rescale it to another resolution to meet your project needs.

#### **4.4.3.1 Description**

The MFT includes an input block, a counter block, an event block and an output block. In this application, no output signal is required, since the counter is expected to produce a value that is read in registers.

The MFT must provide the following functions:

- Use the inputs to drive the counter according to the amount and direction of rotation
- Keep the count undisturbed by events other than the transitions at the inputs
- Allow reading the current counter value
- Allow setting the counter to an arbitrary initial value

We configure the input block to use the two square signals delivered by the encoder to drive the up and down counting of the counter. We do this using a special mode of the input block called "autodiscrimination". In this mode, the input pulses clock the counter, and the phase relationship between the two signals selects up or down counting. Since the process is incremental, once the MFT configured this way, it automatically follows the rotation of the encoder shaft and the counter value reflects its position relative to the position it was in when the counter was configured. In our example, the encoder produces 512 cycles per revolution. Because the counter is 16-bit, it can monitor shaft positions  $65536/512 = 128$  (or +/-64) full revolutions from the original position.

To operate with an encoder as the input pulse source, we need to set the MFT to Continuous Mode. When the counter crosses the FFFF to 0000 boundary in either direction, this is called an End-Of-Count event. In the normal Continuous mode, the End-Of-Count event reloads the counter with the contents of REG0R (or REG1R in biload mode). In this application, no automatic reload may occur at any time so we can use the full range of the counter and be able to cross the boundary. To prevent the reload from occurring, we must set the REG0R register to Capture Mode. The MFT is then said to be in Free-Running Mode.

We have thus selected Free-Running Mode, yet we need to be able to set the counter to any arbitrary value that is taken as the initial position. For this we need to use the REG0R register

as the Load register. The solution is to initialise the MFT with REG0R in capture mode by setting the RM0 bit of the TCR register to ensure Free-Running Mode. When we need to load a value in the counter, we temporarily clear the RM0 bit. Then we set REG0R to the value that must be written in the counter. The CP0 bit in the FLAGR register is pulsed high to write the contents of REG0R into the counter. Then we set bit RM0 again.

#### 4.4.3.2 Initialisation

The code for initializing the MFT is given below.

**Note:** The ICR register sets the input to Autodiscrimination mode. In this mode, the lower four bits are irrelevant.

```
void ConfigTimer1 ( void )
{
    SelectPage (T1D_PG) ;
    T_REG0R = 0 ; /* This register is used to preload the counter */
    T_REG1R = 0 ; /* This register is used to read the counter */
    /* T_CMP0R and T_CMP1R are not used */
    T_TCR = Tm_cen ; /* enable counter */
    /* The counter will not start until the Global Counter Enable is set in
    register CICR */
    T_TMR = Tm_rm0 ; /* capture using REG0R and monitor using REG1R */
    /* This mode is not desired, but it implies free-running, which we need
    */
    T_ICR = Tm_ab_aa ; /* inputs used in autodiscriminating mode */
    /* For so, the port 3 must be set to input on pins P3.4 and P3.6 */
    T_PRSR = 0 ; /* prescaler rate = 1 */
    T_OACR = 0 ; /* output A not used */
    T_OBCR = 0 ; /* output B not used */
    T_FLAGR = 0 ; /* not used */
    T_IDMR = 0 ; /* not used */
}
```

#### 4.4.3.3 Reading

To read the value of the counter, you need to capture it in one of the registers, since the counter itself does not have an address and cannot be read directly. There are two ways of reading the counter:

Set one of the registers REG0R or REG1R to Capture mode. A pulse on bit CP0 or CP1, respectively, transfers the contents of the counter to the corresponding register.

Put REG1R in Monitor mode. In this mode, REG1R continuously reflects the value of the counter, without the need for pulsing a bit in a register.

In the stepper motor application, we have chosen to use Monitor mode. No special function is needed to read the counter. A simple assignment of REG1R to a variable is enough, such as:

```
Pos = REG1R ; /* Get current counter value */
```

#### **4.4.3.4 Updating**

As mentioned in Section 4.5.3.1, updating requires switching the mode of REG0R from Capture to Load.

```
/* This function forces the MFT1 counter to a value given in argument */  
void SetEncoder ( int Value )  
{  
  SelectPage (T1D_PG) ;  
  T_TMR &= ~Tm_rm0 ; /* Switch temporarily to "Load with REG0R" mode */  
  T_REG0R = Value ; /* set encoder */  
  /* convert motor position to match the encoder's resolution */  
  T_FLAGR |= Tm_cp0 ; /* Load counter with this value by pulsing CP0 high */  
  T_FLAGR &= ~Tm_cp0 ; /* Return CP0 to low */  
  T_TMR |= Tm_rm0 ; /* Go back to "Capture with REG0R" mode that implies  
  free-running */  
}
```

#### **4.4.4 MFT Application 1: Generating 2 PWMs using Interrupts**

This application generates 2 independent PWM signals on pins T0OUTA and T0OUTB provided that a logical low level is applied to gate T0INA. The outputs are reset on compare events and set on the counter underflow. This application is found in the MFT/appli1 directory.

Counter compare interrupts are used to reload compare registers in order to modify the duty cycle.

When running one of these three examples on an ST92F120 microcontroller, note that MFT outputs are pure open drain.

#### **4.4.5 MFT Application 2: Generating a PWM using DMA**

This application generates a PWM signal on pin T0OUTA using a DMA channel to transfer duty cycle data from memory to register COMP0. The DMA transfer only occurs once as it is not re-initialized in the DMA end of block interrupt routine. This application is found in the MFT/appli2.

#### 4.4.6 MFT Application 3: Generating a PWM using the DMA Swap Mode

This application generates a PWM signal on pin T0OUTA using the DMA swap mode to transfer duty cycle data from memory to register COMP0. This application is found in the MFT/appli3 directory.

Swap mode uses two sets of DMA registers and swaps from one to the other at the end of each transfer. The end of block interrupt routine reloads the unused set of DMA registers for the next transfer.

### 4.5 SERIAL PERIPHERAL INTERFACE

#### 4.5.1 Description

The SPI is a synchronous input-output port that you can configure in various modes, including S-Bus. It can have many more uses, of which two are considered here: interfacing with serial-access EEPROMs and interfacing with a liquid-crystal display.

The main block of the SPI is an 8-bit shift register which can be read or written in parallel through the internal data bus of the ST9+, and that can shift the data in or out on two separate pins, named SDI and SDO, respectively. The serial transfer is initiated with a write to the SPI Data Register (SPIDR). Data is input and output simultaneously with each most significant bit being output on SDO while the level at SDI becomes the least significant bit. Each time a bit is transferred, a pulse is output at the SCK pin. When eight bits are transferred, eight pulses have been sent on SCK, and the process stops. If the proper bits are set in the SPI Control Register (SPICR), an interrupt can be requested on end of transmission. To summaries:

- Transfers are started by writing a byte into the SPI data register
- Data is input and output at the same time
- Data is input and output with the most-significant bit being sent first
- Eight clock pulses are output on the SCK pin synchronously with bit shifting
- An interrupt request can be issued on end of transmission

The SPI is configured with the SPICR register. Four bits of this register are of special interest in the applications detailed here: these are the CPOL-CPHA pair, and the SPR1-SPR0 pair.

The CPOL-CPHA pair defines the polarity and phase of the clock pulses. This allows them to adapt to the external device. CPOL selects between rising edge or falling edge as the active transition, and CPHA selects whether the first active edge is the first edge of the pulse train or the second one.

The SPR1-SPR0 pair selects one of four different transfer speeds.

### **4.5.2 Static Liquid-Crystal Display Interface Example**

This example uses a static liquid-crystal display that shows a simple number. This can be the voltage in a digital voltmeter, or any 3 1/2 digit value. A very simple demonstration program is supplied in the Companion Software. Some of the routines are reused in the bar code reader described later.

A static liquid-crystal display is composed of a glass back-panel, and a set of front-panel electrodes printed on a glass front-panel. The space between both panels is filled with a liquid-crystal solution. The electrodes are transparent, and the panels may be fitted with a combination of polarisers, so that the whole display, unpowered, is either transparent or opaque according to the selected polariser combination. When a difference of potential is applied between one electrode and the backplane, the area delimited on the front panel by the shape of the electrode takes the reverse state, i.e. opaque or transparent, respectively. Using a seven-segment pattern, it is possible to display numbers, by activating the appropriate segments to show the desired figures.

A liquid-crystal display presents a high impedance between its electrodes, ranging typically in the megaohm region. It is thus a voltage-controlled device, with a threshold of about 3 V to change from one state to the other. Driving such a display is then a simple matter, but one fundamental precaution must be taken to avoid premature destruction of the display: it must be driven with alternating voltage, to avoid electrolysis within the inter-electrode solution. The frequency is of little importance, and the best values range between 30 and 100 Hz.

This basic explanation does not cover all the details and precautions relative to LCDs but is sufficient to understand the use of the SPI as a LCD driver.

In this application, the display is installed on a separate board. Since it has 40 pins, it is not convenient to connect this board with a 40-wire cable. Using a serial synchronous transmission, only four wires are required. The block diagram of the circuit of the display board is:



Figure 43. LCD Interface Example

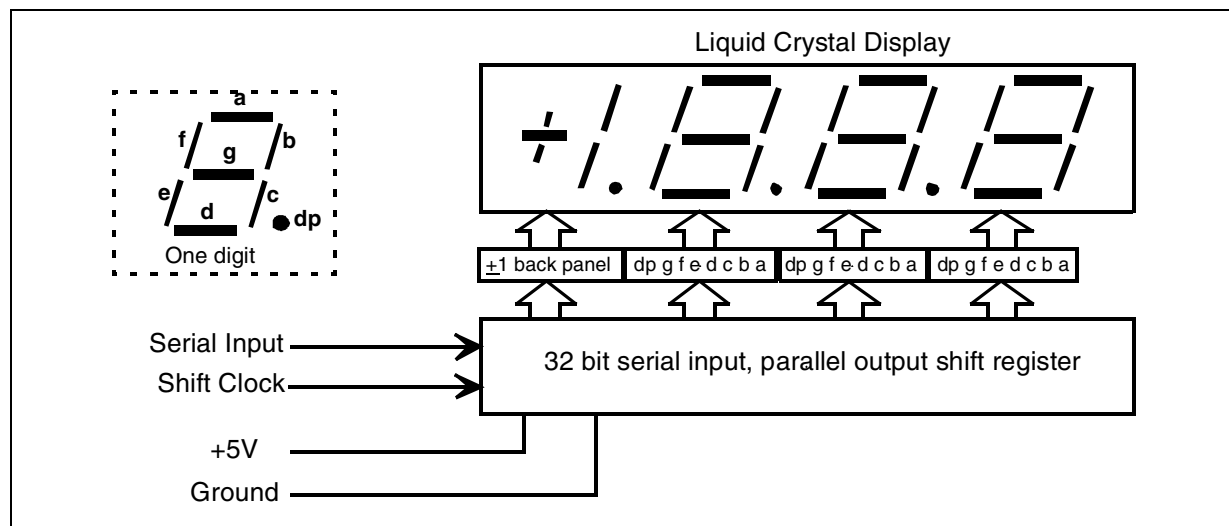

As shown by this diagram, to make it easy to wire our display board, the correspondence between the segment positions and the bit positions in the bytes transferred is actually:

Bit position	7	6	5	4	3	2	1	0
Segment	dp	g	f	a	b	c	d	e

And the conversion between the figures (0 to 9) and the display pattern is done by a constant array defined in this case as:

; Table of characters. Gives the patterns for the last 3 digits, from 0 to 9.

Characters:

.byte 3Fh, 0Ch, 5Bh, 5Eh, 64h, 76h, 77h, 1Ch, 7Fh, 7Eh

The LCD electrodes are connected to the outputs of a serial input, parallel output shift register. The backplane is also connected to one output. This allows us to provide the A.C. drive for the electrodes, as shown in the table below:

Level of the back-plane	Level of one of the segments	State of the liquid crystal between the electrodes
0	0	off
0	1	on, positive voltage
1	0	on, negative voltage
1	1	off

In short, the segment is On if its level is different from that of the backplane. It is Off if its level is the same as that of the backplane. Thus, to generate the drive pattern, it is only necessary to build the four bytes that correspond to the various segments, keeping the bit corresponding to the backplane at level zero. Then, using a periodic interrupt, these four words are trans-

mitted serially, but complemented every other time. As an example, to display the value 375, as in the demonstration program, the following message is built:

Symbols	Hundreds	Tens	Units
00000000	01011110	00011100	01110110

Since in this original message the backplane bit is kept at zero, all bits that are 1 correspond to an activated segment; the others remain invisible. This message is sent at intervals of about 16 ms, but it is inverted every other time, giving the succession:

Symbols	Hundreds	Tens	Units
00000000	01011110	00011100	01110110
11111111	10100001	11100011	10001001
00000000	01011110	00011100	01110110
11111111	10100001	11100011	10001001
00000000	01011110	00011100	01110110
11111111	10100001	11100011	10001001
etc.			

This succession of inverted words guarantee a zero D.C. component across the liquid crystal solution, which is absolutely necessary.

### 4.5.3 EEPROM Serial Interface Example using I<sup>2</sup>C

An I<sup>2</sup>C Serial EEPROM is a very convenient device that stores a few bytes for at least 10 years in a secure manner. The serial I<sup>2</sup>C access uses only two wires, which allows the memory to fit in an 8-pin DIL package. The serial access requires a serial transmission protocol, which makes the access more difficult than with a parallel-bus EEPROM device. This, however, is not a real drawback, for two reasons:

- The serial synchronous transmission is very easy to implement, and is not time-critical
- Using a serial protocol makes it impossible (or very unlikely) that you will overwrite or erase data by mistake, which ensures a high safety level for the application

Thus, for applications that can manage with a small amount of permanent data, a serial EEPROM is the best choice. Examples include storing the reading of a counter or a recording meter, storing configuration parameters or calibration values. The application described here uses a 24C08 memory chip from STMicroelectronics, that takes advantage of the SPI to exchange data with minimum software overhead.

#### 4.5.3.1 Additional Clock Timing

Compared to I<sup>2</sup>C timing, SPI timing needs additional software to manage the following:

- The start condition
- The ninth bit for acknowledgement

– The stop condition

These three timing differences are implemented by changing the input/output port data and configuration registers, to pull the level on the SDA and SCL pins up or down.

#### 4.5.3.2 I<sup>2</sup>C Application 1: Implementation of I<sup>2</sup>C Protocol using the SPI

This example only works on a ST90158 because the ST92F120 does not have the same SPI cell.

In the example the two acknowledge management sub-routines are "I2C\_ACK()" for the output data and "I2C\_WAIT\_ACK()" for the input data. This application is found in the I2C/appli directory.

The start condition sub-routine is "I2C\_START()", and the stop condition sub-routine is "I2C\_STOP()".

Figure 44 shows the I<sup>2</sup>C Timing implemented with additional SPI timing software.

All of these sub-routines are in the "I2C.C" file.

**Figure 44. I<sup>2</sup>C Data and Clock Timing with Additional SPI Software**

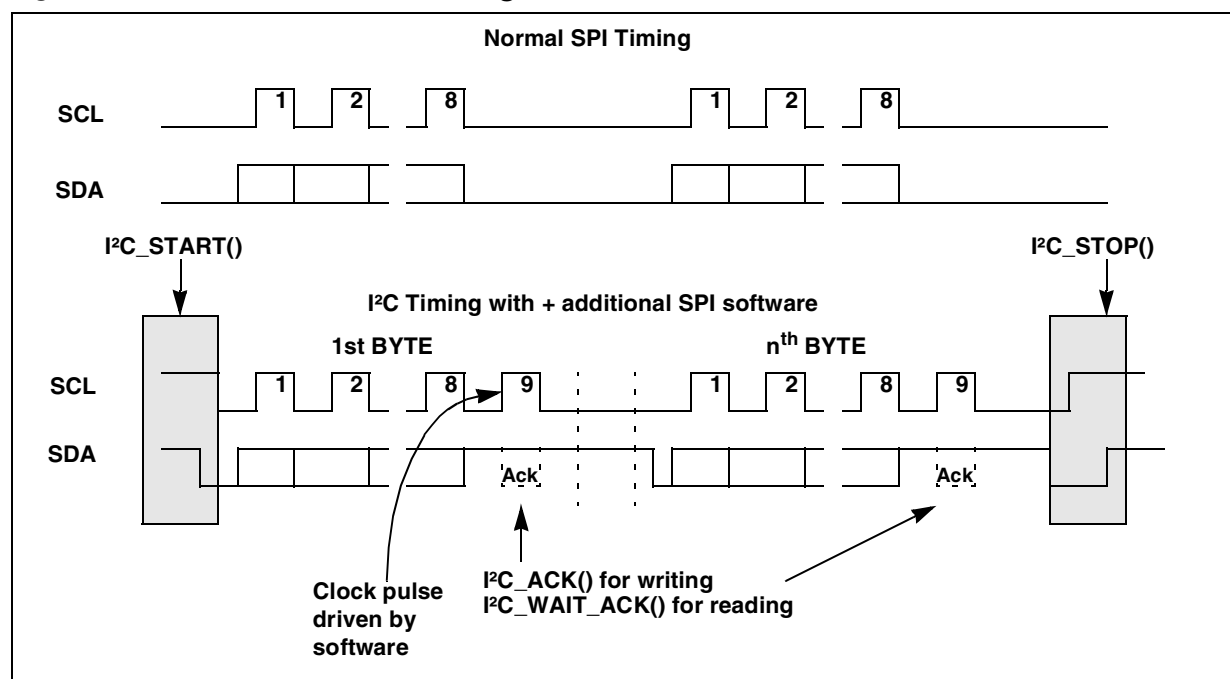

#### 4.5.3.3 EEPROM I<sup>2</sup>C Protocol

To connect more than one device to an I<sup>2</sup>C interface, each device needs an address to be selected. The EEPROM 24C08, used for our example, has an address equal to A0h.

Following a start condition, the bus master (SPI) must output the address of the EEPROM it is accessing. The most significant four bits are the device type identifier (1010). The following bit

identifies the specific memory location on the bus (it is matched to the chip enable signal). Once the 6th and 7th bits are sent, select the block number and the 8th bit sent is the read or write bit (1 for read, 0 for write). After the address has been sent, ten data bytes can be sent to the EEPROM for writing, and all the data bytes can be read successively from the EEPROM for verification.

## **4.6 SERIAL COMMUNICATIONS INTERFACE**

### **4.6.1 Description**

The SCI is the association of a UART and a complex logic that handles tasks such as character recognition and DMA. It can also work as a simple serial expansion port that then resembles the SPI. The example given here appears as a classical UART application, viewed externally, but it is assisted by the built-in DMA controller to provide effortless transfers of data in and out of the application. As serial communication is a feature that is very often used, it will be found in all three applications.

The SCI has four operating modes:

- Asynchronous mode where data and clock can be asynchronous. Each data is sampled 16 times per clock period. The baud rate should be set to the 16 division mode and the frequency of the input clock is set to suit.
- Asynchronous mode with synchronous clock where data and clock are synchronous but the transmit and receive clock are asynchronous. The receive clock must be given by the external peripheral.
- Serial Expansion mode where data and clock are synchronous and the clock is supplied by the transmitter (ST9+ in transmission and externally in reception).
- Synchronous mode where data and clock are synchronous, the transmit data clock is supplied by the ST9+ and the receive data clock is received by the external peripheral. In this mode there are no start and stop bits.

These four operating modes allow you to connect the ST9+ to any external interface.

#### **4.6.1.1 UART**

The UART offers all the usual functions for asynchronous transfer. You can set it to handle word lengths of 5 to 8 bits, with or without parity, even or odd. It offers also the possibility to append a signalling bit (called Address bit or 9th bit -- regardless of the word length) at the end of the transmitted data, just before the stop bit. This can be used to help design a multidrop network. The UART can be set to interrupt the processor only when this bit is high, indicating that the current character is an address or other identifier. This prevents the processor from being disturbed by the traffic on the network unless an address byte is received, so that the processor can check if it is concerned or not by the incoming data.

The UART is set to 8 bits, 1 stop bit and no parity, by writing the appropriate value in the CHCR register.

A timer is part of the SCI block. It is used as a Baud Rate Generator (BRG). It allows you to divide either the internal clock or the frequency available at the RXCLK input pin, by an arbitrary value. This output can be fed to the receive and transmit sections, though each section can have its own clock frequency supplied on pins RXCLK and TXCLK for receive and transmit, respectively. Here, we use the BRG to clock both sections.

At the clock input of the transmit and receive shift registers, two other dividers can be inserted, to further divide the frequency by 16. It must be used in Asynchronous mode to allow detection of the start bit using a local clock. If an external clock is supplied, at the same frequency and phase as the serial incoming data, the 16x divisor must not be used. Here, the predivisor is used.

The UART is surrounded by logic that allows it to detect errors on reception, a break state on the line, and also to recognize a match between the character received and a reference character stored in a register. This last feature is used here. The ACR register is loaded with the value 10 representing the LF character, and the IMR interrupt mask register is set to enable an interrupt on a character match. Since DMA is used to transfer the incoming characters to memory, this technique is used to detect the end of message, if we state that all commands must end with an LF character.

#### 4.6.1.2 DMA Controller

The DMA is used for the automatic data transfer from memory or a register to the serial transmitter or from the serial receiver to a register or memory, or both.

The working of the DMA in conjunction with the UART merits some detailed explanation, because it is subtle and you need to take some precautions to make it work properly. Once initialized, it is easy to use and it consumes very little computing power to initialise transmission or re-enable reception.

The DMA transfers in each direction are controlled by two registers: the DMA transaction counter and the DMA pointer. The transaction counter is used to stop the transaction when a predefined number of characters is transferred. The DMA pointer points to the character to be sent or to the location that will hold the next character to be received. To initialise a DMA transfer, the transaction counter must be set to the number of characters to be transferred and the DMA pointer must be set to the beginning of the storage area that contains the data to be transmitted or that will hold the data string received.

Transfers can occur between the UART and either the memory or register file.

The transaction counter and the DMA pointer must be registers in the register file. If the register file is involved in the transfer, both the transaction counter and the pointer must be single

bytes (the addressing range of the register file is 0 to 255). If the memory is involved, the counter and the pointer must be each a pair of registers, since the addressing range in memory is 0 to 65535 for one segment.

Once you have defined in which registers you will put the counter and the pointer, you must let the SCI know. The SCI has two registers for this purpose called the DMA Address Pointer Register (DAPR) and DMA Counter Pointer Register (DCPR). These registers are not the actual counter and the pointer, they point to where you want to locate them in the register file. This double pointer mechanism is similar to that described for interrupts.

Here there can be two cases: the transfer involves the memory or the register file.

If the transfer involves the memory, it's standard procedure. The DCPR points to the 16-bit Counter register, and the DAPR points to the 16-bit Address register. These two register pairs may reside anywhere there is room for them in the register file. Since register pairs are used, their addresses are even. The DCPR must be even. To reach the DMA segment the DMASR (or ISR depending on DAPR bit 0) MMU register contains the segment number.

If the transfer involves the register file, things are a bit different. Both the transaction counter and the address register are 8-bit values. They are supposed to be adjacent in the register file, i.e. they occupy two successive registers: the first one, even numbered, is the address register. The second one, odd numbered, is the transaction counter. To select this mode, the least significant bit of the DCPR must be one. Its value is the address of the address register (which is even) plus one. The DAPR is not used.

The whole mechanism described above applies for both the transmitter side and the receiver side. Thus, there are twice as many registers as mentioned: the TDCPR and the TDAPR for the transmitter side, the RDCPR and the RDAPR for the receiver side. The registers you have located in the register file are also twice as many. So, the TDCPR points to the transmitter transaction counter and the TDAPR points to the transmitter address register (with the exception mentioned above if the transaction involves the register file). The RDCPR points to the receiver transaction counter and the RDAPR points to the receiver address register.

When a DMA transfer is in progress, the processor is not even aware of it (except that it is slightly slowed down by the stolen clock cycles). So nothing special has to be done as far as the program is concerned. The question is: how to start and end a DMA transfer? Here, the processor is involved, and some code is needed. Depending on which side is concerned, the processes are different.

#### **4.6.1.2.1 Transmitter Side**

To start a DMA transmission, you need to do the following operations, in order:

- Set the DMA segment register DMASR (or ISR) to point to the selected segment of data memory.

- Set the transmit address register to the address of the second word to be sent (not the TDAPR, which is only set once at initialisation, and points permanently to the transmit address register).
- Set the transmit transaction counter to the number of characters to be transmitted minus one (not the TDCPR, which is also only set once at initialisation, and points permanently to the transmit transaction counter).
- Set the TXD bit of the IDPR register. This bit enables the Transmitter holding register empty flag (TXHEM bit of register ISR) to trigger a DMA transfer when the last character is sent. When TXD is reset, the holding register empty flag would trigger an interrupt instead.
- Load the Transmit Buffer Register (TXBR) with the first character to be sent. This starts the DMA process as soon as this character is transmitted.
- Clear the Transmitter holding register empty flag (TXHEM bit of register ISR) and the Transmitter buffer register empty flag (TXSEM bit of register ISR) to prevent DMA transfer from starting before the first character is fully transmitted.
- Enable the end of DMA interrupt by setting the Transmitter Data Interrupt Mask (TXDI bit of register IMR).

The DMA is now started and will stop when the transaction counter reaches zero.

**Note:** The transmit address register is initialized with the address of the **second** word and the transmit transaction counter is initialized to the number of characters to be transmitted **minus one**, because the DMA transfer begins when the first word is transmitted (a write in the Transmit Holding Register), so the first word is transmitted "by hand".

#### 4.6.1.2.2 Receiver Side

The receiver side is a little more complicated as two kinds of events can occur during reception:

- There can be transmission errors that must be handled.
- A break is received or a character match event can occur.

The receiver is set in a ready for DMA condition by the initialisation code.

Reception normally finishes when the DMA transaction counter has reached zero. But this is not necessarily the way one wants to use the serial input, since it implies that the number of characters to be received must be known before the transfer starts. In most cases, character-type messages have a variable length.

In this application, the transaction counter is not expected to reach zero, since the size of the buffer assigned for reception exceeds the longest message defined in the specification. Thus, if the transaction counter reaches zero this is in fact an overflow condition. In this case, the contents of the buffer are discarded and a new reception is initiated. In both cases, the steps to perform an End of Block are:

- Reset the Receiver End of Block (RXEOB bit of register IMR) to remove the interrupt request.
- Use the received characters, if required.
- Re-enable the end of block interrupts by setting the Receive DMA Bit (RXD bit of register IDPR).
- Restore the DMA capability by setting the receive address pointer (not the RDAPR) to the address of the beginning of the receive buffer.
- Set the receive transaction counter (not the RDCPR) to the number of characters to be received. This will re-enable the DMA capability.

In a typical application, command messages could have variable length and be terminated by an LF character. So, the character match event capability built in to the SCI should be used.

If the Address/Data Compare Register (ACR) contains the value 10 (ASCII code for LF), and the Receive Address Mask (RXA bit of register IMR) is set, whenever an LF character is received, an interrupt is generated. This interrupt is considered in the application as a good Message Received signal. It is processed the following way:

- In this application, no other characters are expected until the previous message has been answered by the program. However, it may be useful to inhibit further DMA cycles by clearing the RXD bit in the IDPR register and also the RXDI bit in the IMR register.
- Read the Receive Buffer Register (RXBR) to remove the interrupt request (see note below).
- Make use of the received characters.
- Restore the DMA capability by setting the receive address pointer (not the RDAPR) to the address of the beginning of the receive buffer.
- Set the receive transaction counter (not the RDCPR) to the number of characters to be received. This will re-enable the DMA capability.

**Note:** When matching occurs between the incoming character and the ACR register contents, the DMA request is not generated, neither is an interrupt request for "character received". So, the incoming character remains in the receive buffer and no other character can be received until it has been removed. This is why it is not sufficient to clear the RXAP bit in the ISR register to reinstate the DMA transfer. You must clear the RXBR register by reading it during the character match interrupt service routine.

Finally, an error may occur during transmission. This can be a parity error (if parity checking is enabled), a framing error or an overrun error. If one of these errors occurs, take the following steps:

- Clear the bits that indicate an error condition in the ISR register.
- Restore the DMA capability by setting the receive address pointer (not the RDAPR) to the address of the beginning of the receive buffer.
- Set the receive transaction counter (not the RDCPR) to the number of characters to be received. This will re-enable the DMA capability.



#### 4.6.1.2.3 Interrupt Vectors

The interrupt vector scheme has been explained in Section 3.4.1 using the example of the MFT to illustrate the mechanism. Here is the equivalent table for the SCI giving the position of the four vectors dedicated to the four interrupt causes.

<b>Value in IVR</b>	50
---------------------	----

<b>Interrupt cause</b>	<b>Address in ROM of the selected pointer</b>	<b>Value of the Pointer to interrupt routine</b>
Receiver error	50	Address of error processing routine
Break detect or address match	50+2	Address of Address match processing routine
Receiver data ready or DMA end of block	50+4	Address of receive DMA end of block processing routine
Transmitter buffer empty of DMA end of block	50+6	Address of transmit DMA end of block processing routine

#### 4.6.2 SCI Application 1: Sending Bytes using Interrupts

This application sends 10 bytes to the USART. An interrupt is generated at the end of every single byte transmission. During this interrupt routine, the TXBR register is loaded with the next byte to be transmitted. This application is found in the SCI/appli directory.

The character format is: 2400 bauds, 8 data bits, 1 stop bit and odd parity. Sent bytes can be received on a PC loaded with a serial communication management software program such as Hyperteminal.

#### 4.6.3 SCI Application 2: Sending Bytes using DMA

This application sends bytes from the memory to the SCI peripheral using a DMA channel. The transfer is re-initialized twice in the DMA End of Block interrupt routine so that data is transmitted three times. This application is found in the SCI/appli2 directory.

#### 4.6.4 SCI Application 3: Sending and Receiving Bytes using DMA

This application sends bytes from the memory to SCI and receives bytes from SCI to the register file using two DMA channels. The SCI cell is configured in loopback so that each byte sent is immediately received by the SCI. This application is found in the SCI/appli3 directory.

#### 4.6.5 SCI Application 4: Matching Input Bytes

This application receives bytes from the USART and reacts only if an "F" (upper case) is received: on a character match, a "0" is displayed on the 7-segment LED display on port 4. This application is found in the SCI/appli4 directory.

### 4.7 ANALOG TO DIGITAL CONVERTER

#### 4.7.1 Description

The analog to digital converter is one of the simplest peripherals of the ST9+ family to use. It converts the voltage applied to one of eight inputs using an 8-bit successive approximation analog to digital converter. According to the value of bits SC2, SC1 and SC0 of the Control Logic Register (CLR), one to eight inputs are converted at each conversion cycle, starting at the channel number specified by these bits and ending with channel 7.

The simplified block diagram is the following:

Figure 45. A/D Converter Block Diagram

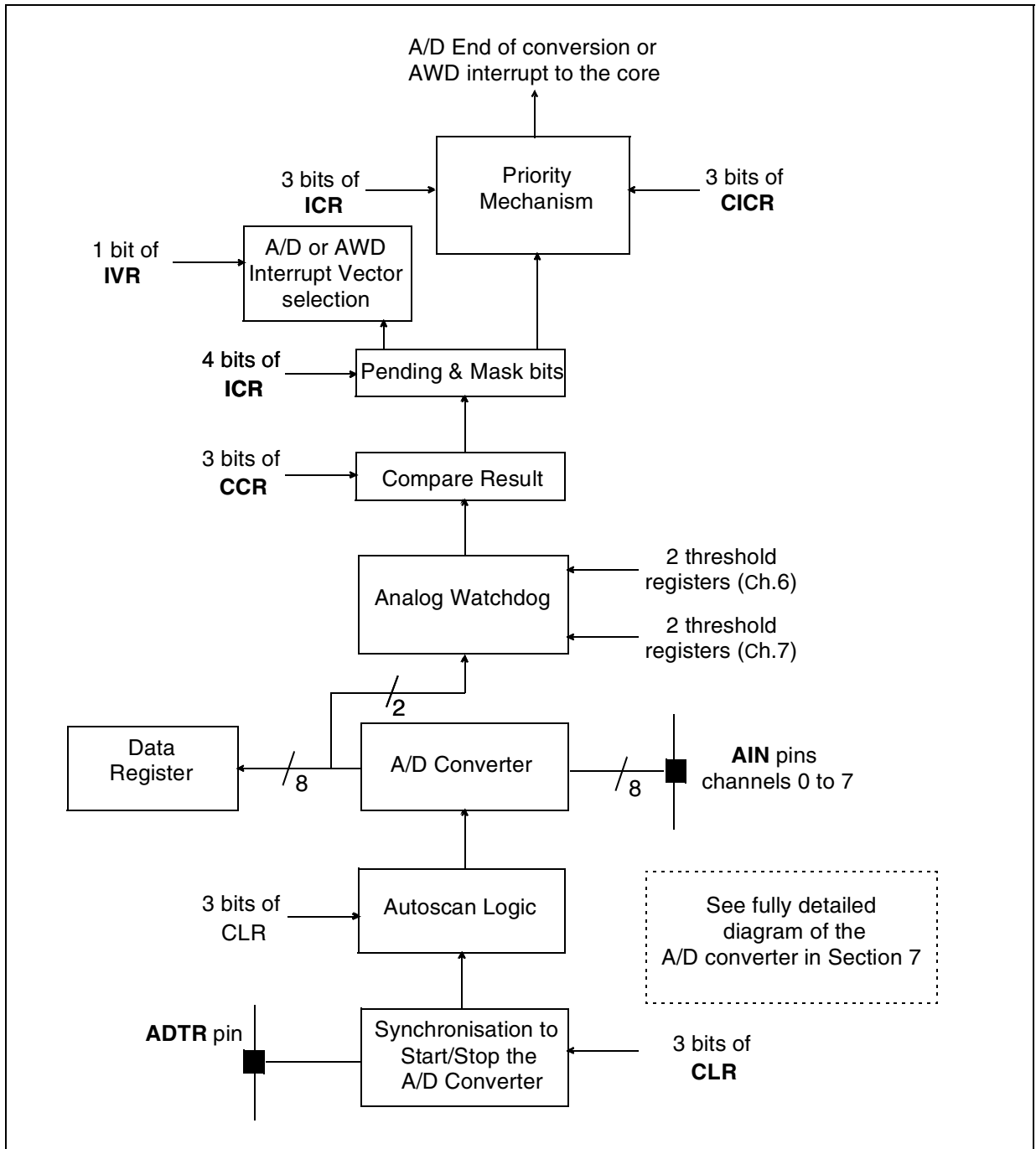

The conversion cycle can either be started in Single-shot mode, by a trigger (software or hardware, the latter being internal or external) or in Continuous mode, restarted as soon as the previous cycle is finished.

Each channel uses one bit of a port (the port depends on the variant of the ST9+), and the conversion result is stored in a register. Eight such registers are available, named D0R to D7R.

The end of conversion sets the ECV bit in the ICR register, and can trigger an interrupt request, if the ECI bit (mask of the end of conversion interrupt request) of the Interrupt Control Register (ICR) is set.

**Notes** The internal interrupt controller does not automatically reset the ECV bit. It must be reset by the interrupt service routine prior to returning from interrupt. Failure to do this would cause the interrupt to loop endlessly.

As mentioned in Section 4.2 on parallel ports, you must configure the corresponding pins to alternate function both to reduce loading on the analog source and to avoid excessive dissipation in the pin's input buffer. For the same reason, it is advised to keep this I/O configuration if an analog voltage is present on the pin, even if it is not being converted at this time.

### 4.7.2 Analog Watchdog

A special feature of this peripheral is the so-called Analog Watchdog. If enabled, the values of D7R or both D6R and D7R are each compared after each conversion with a pair of upper and lower thresholds stored in registers LT6R and UT6R, for D6R, and LT7R and UT7R, for D7R. If the value is outside the bounds, the AWD bit of the ICR register is set. This can trigger an interrupt request if the AWDI bit of the same register is set. To know which of the four thresholds has been exceeded, the Compare Result Register (CRR) has four bits with one each corresponding to one of these thresholds. The appropriate bit is set when the threshold has been exceeded.

**Notes:** The AWD bit, like the ECV bit, is not automatically reset by the internal interrupt controller. Thus it must be reset by the interrupt service routine prior to returning from interrupt. Failure to do this would cause the interrupt to loop endlessly.

To permit power saving in applications where energy conservation is important, you can power the ADC on and off so that it only consumes power when used. However when you switch it on, a delay of 60  $\mu$ s may occur. The reset condition is off.

### 4.7.3 Interrupt Vectoring

Two vectors are dedicated to the ADC: the end of conversion vector and the analog watchdog vector. This allows these two events to be serviced by two different routines. The vectors used depends on the state of the W1 bit in the IVR register. This bit is set or reset according to the source of the interrupt.

However, it may occur that both interrupts are generated simultaneously. In that case, the analog watchdog takes over.

#### 4.7.4 ADC Application: A/D Conversions and Analog Watchdog using Interrupts

This application converts the analog value presented on P77 and enters the conversion results in a chart as long as the converted value resides within the user-defined threshold. The end of conversion interrupt is used to transfer the result of the conversion to the chart. The analog watchdog interrupt, when triggered, stops the A/D converter. This application is located in the ADC/appli directory.

### 4.8 PERIPHERAL INITIALIZATION

All the ST9+ peripherals have a large number of configuration options. This makes them highly adaptable, but has a complex initialization procedure.

To help you to use the peripherals easily, you can find all the initialization programs on the <<http://www.st.com>> internet site.

The purpose of these programs is to give you C language programs to get started with programming each peripheral. This program package consists of a Header file, a peripheral function, a startup and a main program for each peripheral.

The startup (crtbegin.spp) and the main (main.c) files are not explained here. Have a look at these files for more details. All you now have to know is that whenever an interrupt subroutine is used, the startup program is initialized with the interrupt subroutine address.

For example the INTADC\_EndConv() ADC interrupt subroutine address declared in the file <adc.c> is loaded in the startup routine <crtbegin.spp> at the Interrupt Vector Register location.

#### 4.8.1 initialization Header File

The initialization header file defines all the constants, the file to be included, the function prototypes and the peripheral mode.

The initialization header file has to be included any time the peripheral is referenced. The next section uses the Analog to Digital Converter peripheral file as an example. The ADC initialization header file is <adc.h>.

##### 4.8.1.1 Constants already Initialized and to be Initialized

The <adc.h> file is complementary to the <ad\_c.h> header file located in the toolchain header files directory, with the other peripheral header files.

The 8 initialized constants, CHANNEL0 to CHANNEL7, give you the 8 possibilities of initializing the non-initialized constant AD\_CHANNEL. This constant will initialize the AD\_CLR ADC Control Logic Register in the <adc.c> file.

### **4.8.1.2 Files to be Included**

The files to be included contain other initialized constants like in the previous <adc.h> file.

### **4.8.1.3 Function Prototype Declarations**

Each of these functions can be called by the main program <mainc.c> or other functions for managing the ADC. They are defined in the <adc.c> file.

The <adc.h> file function prototypes are:

```
void INIT_ADC(void);  
void START_ADC(void);  
void STOP_ADC(void);  
void INIT_ADC_IT(void);  
void Enable_ADC_IT(void);
```

### **4.8.1.4 Defining the Functional Mode**

To initialize the peripheral mode, you can activate the define directive by removing the << /\* \*/ >>.

e.g.: In the <adc.h> file, you can select Continuous mode with:

```
#define continuous  
/*#define single*/
```

## **4.8.2 Peripheral Function File**

These files contain the peripheral management functions. The function prototypes are placed in the header file as explained before.

The functional mode and the constants initialized in the header file modify the functions so that they can be used directly by the application program.

### **4.8.2.1 Presentation of Peripheral Function Files**

#### **4.8.2.1.1 ADC File**

The ADC function file is <adc.c> and contains 6 functions initialized for using channel 7 of the ADC corresponding to I/O port P77. It performs 15 conversions and stores the converted values in chart measures. Moreover, the analog watchdog is enabled on this channel and stops the series of conversions if the value is not within the prescribed thresholds.

**Table 4. ADC.C Functions**

Function	Description and Comments
void INIT_ADC(void);	Choice between Continuous and Single-shot modes. Possibility of initializing the analog watchdog on channel 6 or/and 7.
void START_ADC(void);	Choice between three triggers to start the conversions: internal, external or software.
void STOP_ADC(void);	This routine stops the ADC after a series of conversions. Afterwards, all power consuming logic is disabled (low power idle mode).
void INIT_ADC_IT(void);	The pointer to the array of two IT vectors dedicated to the AD is initialized. The priority of these interrupts is initialized. This routine initializes both end of count and analog watchdog. Don't forget to initialize your start-up file correctly.
void Enable_ADC_IT(void);	This routine enables interrupts: End of Conversion or/and Analog Watchdog.
void INTADC_AnaWd(void);	<b>Interrupt subroutine</b> dedicated to Analog Watchdog.
void INTADC_EndConv(void);	<b>Interrupt subroutine</b> which occurs after an end of conversion event.

#### 4.8.2.2 SPI File

The SPI function file is <I2C.c> and contains 10 functions initialized to perform data exchange between the ST90158 and an EEPROM connected on an I<sup>2</sup>C bus at the I<sup>2</sup>C address 0xA0. Both read and write operations are performed:

- First, it writes the contents of chart display into the EEPROM.
- Then, it checks this write operation by reading the EEPROM using interrupts.

Read data are stored in chart EEPROM\_REC.

The ports used for this application are:

- P5.1 SDI
- P9.7 SDO
- P9.6 SCL

**Table 5. I2C.C Functions**

#### 4.8.2.2.1 MFT Files without DMA

The MFT function file is <mft\appli1\mft.c> and contains 6 functions that are initialized for generating two PWM signals using the two output pins of the MFT0.

Compare0 and Compare1 events are managed by interrupts.

Input A is used as a gate: as long as a +5V level is applied on it, the counter stops down-counting and the PWM signals are thus not generated.

The following ports are used for this:

Function	Description and Comments
void INIT_I2C (void);	<p>Port initialization:(ST90158!)</p> <ul style="list-style-type: none"> <li>- P9.6: SCL (I<sup>2</sup>C Clock)</li> <li>- P9.7: SDO (I<sup>2</sup>C Data)</li> </ul> <p>These two pins are initialized as: ALTERNATE FUNCTION, OPEN DRAIN, TTL</p> <p>The other pins of port9 are: BIDIRECTIONAL, WEAK PULL UP, TTL</p> <ul style="list-style-type: none"> <li>-P7.1: SDI (I<sup>2</sup>C Data)</li> </ul> <p>This pin is initialized as INPUT. The SPI is configured to work with I<sup>2</sup>C protocol. For the moment, the I<sup>2</sup>C bus remains disabled (clock not generated). If INTCLK &gt; 12.8 MHz, change the value of constant I2C_SPEED in the i2c.h file.</p>
void I2C_WAIT(void);	<p>This is a loop of 4.7µs (including call and ret cycles)</p> <p>With an INTCLK of 12MHz, we need 57 cycles.</p> <p>This routine is written for INTCLK = 12 MHz</p>
void I2C_START(void);	<p>This generates a start signal for I<sup>2</sup>C communications.</p> <p>While SCL remains high, SDA turns from high to low level.</p>
void I2C_STOP(void);	<p>This generates a stop signal for I<sup>2</sup>C communications.</p> <p>While SCL remains high, SDA turns from low to high level.</p>
void I2C_WAIT_ACK(void);	<p>This function waits for an ACK from the slave.</p> <p>To perform an ACK, the slave must force SDA to Low level.</p> <p>The ST9+ polls the SDA pin configured in input, during "timeout".</p> <p>If an ACK does not occur during this time, a STOP is generated, and the communication ends.</p> <p>If an ACK occurs before the end of timeout, the process leaves the function, ready to send new data.</p>
void I2C_ACK(void);	<p>This function generates a software ACK from the ST9+:</p> <p>During 4.7µs, SCL remains high while SDA is forced to low level.</p> <p>Used in read operations.</p>
void I2C_SEND_DATA(unsigned char sendbyte);	<p>Unsigned char sendbyte: the byte to send to the slave (data, I<sup>2</sup>C address...)</p> <p>sendbyte is sent on the I<sup>2</sup>C bus.</p> <p>This function can be used after: I2C_START() or I2C_WAIT_ACK().</p> <p>The process remains in the function while the Busy Flag remains in the HIGH level (the transmission is not finished).</p> <p>If your software uses interrupts to send data on the I<sup>2</sup>C bus, delete the last line of this function (polling).</p>
void I2C_READ_DATA(void);	<p>0xFF is written in the data register to start the transmission.</p> <p>This function must be followed by I2C_ACK().</p> <p>If your software doesn't use interrupts to read data from the I<sup>2</sup>C bus:</p> <ul style="list-style-type: none"> <li>-Check that the busy flag is cleared before leaving this function.</li> <li>- Modify this function so that it returns the read value (unsigned char I2C_READ_DATA(void)).</li> </ul>



Function	Description and Comments
void INIT_I2C_IT(void);	This routine configures the interrupts after each I <sup>2</sup> C End of Transmission using interrupt channel INTB0. Don't forget to initialize your start-up file correctly.
void Enable_I2C_IT(void);	Enable I2C interrupts on channel INTB0.
void INTI2C_EndTrans(void);	<b>Interrupt subroutine</b> which occurs after an I <sup>2</sup> C End of Transmission. The "user part" presents the way to deal with read data from the I2C bus (it reads 10 bytes from EEPROM and stocks them in EEPROM_REC).

– T0OUTB

– T0OUTA

– T0INA

**Table 6. APPLI1\MFT.C Functions**

Function	Description and Comments
void INIT_MFT(void);	MFT initialization. It initializes the value loaded into the prescaler and into the counter.
void START_MFT(void);	Start the MFT.
void STOP_MFT (void);	Stop the MFT.
void INIT_MFT_IT(void);	This function configures the IT for the MFT.
void Enable_MFTCM_IT(void);	Enables Compare0 and Compare1 IT.
void INTMFT_Compare(void);	<b>Interrupt subroutine</b> which occurs after: - Compare 0 - Compare 1 Only one IT vector.

#### 4.8.2.2.2 MFT files with DMA

The MFT function file is <mft\appli2\mft.c> and contains 7 functions that are initialized for generating a PWM signal using the MFT and a DMA channel.

The port used for this application is:

– T0OUTA

Table 7. APPLI2\MFT.C Functions

Function	Description and Comments
void INIT_MFT(void);	MFT initialization. It initializes the value loaded into the prescaler and into the counter.
void START_MFT(void);	Start the MFT.
void STOP_MFT (void);	Stop the MFT.
void INIT_MFT_ITDMA(void);	This function configures the IT and the DMA for the MFT.
void Enable_MFTCP0_DMA (unsigned int * CompBuffer, unsigned int Count);	Enable Compare0 DMA.
void INTMFT_CompEOB(void);	<b>Interrupt subroutine</b> which occurs after a compare0 DMA end of block. The DMA is not re-initialized so only one block is transferred. Same vector as compare0 interrupt.
void INTMFT_OUF(void);	<b>Interrupt subroutine</b> which occurs after an underflow. It stops the timer when the whole PWM signal has been generated.

#### 4.8.2.2.3 MFT files with DMA in Swap Mode

The MFT function file is <mf\appli3\mft.c> and contains 6 functions that are initialized for generating a PWM signal using the MFT and a DMA channel working in Swap mode.

The port used for this application is:

– T0OUTA

Table 8. APPLI3\MFT.C Functions

Function	Description and Comments
void INIT_MFT(void);	MFT initialization. It initializes the value loaded into the prescaler and into the counter.
void START_MFT(void);	Start the MFT in the swap mode.
void STOP_MFT (void);	Stop the MFT.
void INIT_MFT_ITDMA(void);	This function configures the IT and the DMA for the MFT.
void Enable_MFTCP0_DMA(unsigned int * CompBuffer, unsigned int Count)	Enable Compare0 DMA.
void INTMFT_CompEOB(void);	<b>Interrupt subroutine</b> which occurs after a compare0 DMA end of block. The DMA is swapped.

#### 4.8.2.2.4 RCCU File

The RCCU file is <rccu\rccu.c> and contains 5 functions for controlling the RCCU in your application. The header file has no uninitialized constants since the functions are dedicated.

**Table 9. RCCU.C Functions**

FUNCTION	DESCRIPTION AND COMMENTS
void INIT_PLL(void);	Initialize the PLL, Mul. by 6, div. by 1. Wait 500µs to stabilize the PLL.
void INIT_clock2(void);	INTCLK = CLOCK2 = EXT OSCILLATOR / 2.
void INIT_clock2_16(void);	INTCLK = CLOCK2/16 = EXT OSCILLATOR / 32.
void SWITCH_TO_EXTCLK(void);	Stop the Xtal oscillator and select the external clock (if present).
void BACK_TO_XTAL(void);	Restart the Xtal oscillator and select it as the clock source.

#### 4.8.2.2.5 SCI Files

The SCI function file is <sci\appli1\sci.c> and contains 4 functions that are initialized for sending ten bytes from the ST9+ to the serial link (RS232).

It uses End of Transmission interrupts.

Port used:

– Tx (S0OUT)

**Table 10. SCI.C Functions**

FUNCTION	DESCRIPTION AND COMMENTS
void INIT_SCI(void);	Initialization of general parameters dedicated to the SCI: - Baud Rate Generator: 9600 bauds. - Characters: Eight data bits, one stop bit, odd parity. - Pins... The baud rate generator must be initialized following this structure (BRGHR first and BRGLR at the end).
void INIT_SCI_IT(void);	Initialization of the IT: vector, priority.
void SCI_SendByte(unsigned char ToSend);	It sends byte ToSend to serial link. This routine also enables end of transmission IT.
void INTSCI_TransmitReady(void);	<b>Interrupt subroutine</b> which occurs after the transmission of one character. If 10 bytes have been transferred, it disables the IT and so stops the transmission.

#### 4.8.2.2.6 SCI Files using DMA

The SCI function file is <sci\appli2\sci.c> and contains 4 functions that are initialized for sending 26 bytes from the ST9+ to the serial link (RS232) by using the DMA.

It uses DMA channel (from memory).

Port used:

– Tx (S0OUT) (Uses End of Transmission interrupts).

Table 11. SCI.C Functions

FUNCTION	DESCRIPTION AND COMMENTS
void INIT_SCI_DMA(void);	Initialization of general parameters dedicated to the SCI: - Baud Rate Generator: 9600 bauds. - Characters: Eight data bits, one stop bit, odd parity. - Pins... The baud rate generator must be initialized following this structure (BRGHR first and BRGLR at the end). Initialization of the IT: vector, priority. Initialization of DMA in transmission
void START_SendDMA(unsigned char * TransmitBufferMem, unsigned int SCI_count);	After a few extra initialization, the transmission starts by loading data register(TXBR) with the first value to send.
void INTSCI_TransmitEOB(void);	<b>Interrupt subroutine</b> which occurs when a whole block of data has been transferred using DMA. In fact, the buffer "table" is sent three times and then DMA is disabled.

#### 4.8.2.2.7 SCI Files using DMA in the Loopback Mode

The SCI function file is <sci\appli3\sci.c> and contains 5 functions that are initialized for sending 26 bytes from memory to the serial link.

The SCI is in Loopback mode, so that the bytes sent are then received by the SCI and stored in the register file (from R16).

It uses DMA channels:

- From memory to peripheral for the transmission
- From the peripheral to the register file to receive the bytes.

No ports are used.

Table 12. SCI.C Functions

FUNCTION	DESCRIPTION AND COMMENTS
void INIT_SCI_DMA(void);	Initialization of general parameters dedicated to the SCI: - Baud Rate Generator: 9600 bauds. - Characters: Eight data bits, one stop bit, odd parity. - Pins... The baud rate generator must be initialized following this structure (BRGHR first and BRGLR at the end). Initialization of the IT: vector, priority. Initialization of DMA in transmission and reception. Bit b0 of DAPR registers must be set to 1!!!
void START_DMA(unsigned char * TransmitBufferMem, unsigned int SCI_count)	After a few extra initialization, the transmission starts by loading data register (TXBR) with the first value to send. DMA is enabled in transmission and reception.
void INTSCI_TransmitEOB(void);	<b>Interrupt subroutine</b> which occurs when a whole block of data has been transferred using DMA. Only one block of data is sent (DMA not re-initialized after this IT).
void INTSCI_ReceiveEOB(void);	<b>Interrupt subroutine</b> which occurs when a whole block of data has been received using DMA. Only one block of data is received (DMA not re-initialized after this IT)

#### 4.8.2.2.8 SCI Files using Character Matching

The SCI function file is <sci\appli4\sci.c> and contains 5 functions that are initialized for receiving data on the input pin of the SCI and it only reacts when it receives character SCI\_MATCH (defined in sci.h).

Port used: Rx (S0IN)

Table 13. SCI.C Functions

FUNCTION	DESCRIPTION AND COMMENTS
void INIT_SCI(void);	Initialization of general parameters dedicated to the SCI: - Baud Rate Generator: 9600 bauds. - Characters: Eight data bits, one stop bit, odd parity. - Pins... The baud rate generator must be initialized following this structure (BRGHR first and BRGLR at the end).
void INIT_SCI_IT(void);	Initialization of the IT: vector, priority. The only interrupt which is enabled is "character match".
void INTSCI_ReceiveMatch(void);	This <b>interrupt subroutine</b> occurs when the SCI cell has received the matching character. In this example, it displays 0 on a 7-segment LED connected to port 4.

#### 4.8.2.2.9 ST Files

The ST function file is <sttimer.c> and contains 6 functions that are initialized for generating a simple PWM signal using the Standard Timer (programmable duty cycle).

Port used:

– STDOUT

Table 14. TIMER.C Functions

FUNCTION	DESCRIPTION AND COMMENTS
void INIT_ST(void);	Standard Timer initialization. It must be used before any use of the ST. It initializes the value loaded into the prescaler and into the counter. To use the ST in output mode, you <b>must</b> initialize the output pin in push-pull, <b>alternate function</b> . This means (PXC0R,PXC1R,PXC2R) = (1,1,0).
void START_ST(void);	Starts the Standard Timer.
void STOP_ST (void);	Stops the timer counter.
void INIT_ST_IT(void);	This routine configures the interrupts after each End of Count. Don't forget to initialize your start-up file correctly.
void Enable_ST_IT(void);	Enables the Standard Timer Interrupt.
void INTST_EndCount(void);	<b>Interrupt subroutine</b> which occurs after an end of count.

#### 4.8.2.2.10 WDT Files for PWM Generation

The WDT function file is <wdt\appli1\wdt.c> and contains 7 functions that are initialized for generating a simple PWM signal using the WDT (programmable duty cycle).

Port used:

– WDOOUT

**Table 15. WDT.C Functions**

FUNCTION	DESCRIPTION AND COMMENTS
void INIT_WDT(void);	WDT initialization. It must be used before any use of the WDT. It initializes the value loaded into the prescaler and into the counter. To use the WDT in output mode, you <b>must</b> initialize the output pin in push pull, <b>alternate function</b> . This means (PXC0R,PXC1R,PXC2R) = (1,1,0)
void START_WDT(void);	Start the Watchdog Timer.
void STOP_WDT (void);	It stops the counting of the timer (useless in watchdog mode).
void Restart_Watchdog(void);	This routine refreshes the Watchdog counter: At each End of Count, if this function has not been used before, a reset is generated internally. The periodic use of this function is the only way to avoid a reset.
void INIT_WDT_IT(void);	This routine configure the interrupts after each End of Count using interrupt channel INTA0. NMI is thus configured as the Top Level Interrupt. Don't forget to initialize your start-up file correctly.
void Enable_WDT_IT(void)	Enable the WDT interrupt.
void INTWDT_EndCount(void);	<b>Interrupt subroutine</b> which occurs after an end of count. The code written in the user part allow the generation of a simple PWM signal (programmable duty cycle).

#### 4.8.2.2.11 WDT Files in Watchdog Mode

The WDT function file is <wdt\appli2\wdt.c> and contains 4 functions that are initialized for enabling the WDT in Watchdog mode and refreshes it regularly.

No port is used.

Table 16. WDT.C Functions

FUNCTION	DESCRIPTION AND COMMENTS
void INIT_WDT(void);	WDT initialization. It must be used before any use of the WDT. It initializes the value loaded into the prescaler and into the counter.
void START_WDT(void);	Start the Watchdog Timer.
void STOP_WDT (void);	It stops the counting of the timer (useless in watchdog mode).
void Restart_Watchdog(void);	This routine refreshes the Watchdog counter: At each End of Count, if this function has not been used before, a reset is generated internally. The periodic use of this function is the only way to avoid a reset.

## 5 USING THE DEVELOPMENT TOOLS

### 5.1 DEVELOPING IN C LANGUAGE

Although the ST9+ C Compiler is an optional product, you are strongly advised to write your software using a High Level Language. Naturally for the sake of optimization, especially to obtain the best execution times from certain frequently-used pieces of code, assembly language will still remain the right choice. This will be true at least for the initialisation file. But writing a complete program in assembler has few advantages and many drawbacks, so there can be no economic justification for using only assembler.

This is why some of the examples in this guide are written in assembler and some in C. The development tools allow you to mix both languages easily.

A useful book, if you have some experience of C language is "The C language", by Kernighan and Ritchie, second edition.

### 5.2 AVAILABLE TOOLS

The following tools are available for the ST9+ family:

- A Software development package, named GNU9P, that includes a C-compiler and a Make utility.
- A range of emulators for the various sub-families.

You have two options in terms of development tool products. A software development package is delivered with each emulator. This does not include the C-compiler. You must purchase it separately. So with the emulator package alone you can only do assembler programming.

As previously mentioned, you are strongly advised to use C programming as much as possible, for the obvious reasons of structuring the source code, of code portability and reusability. In addition, developing the program is much easier and more reliable due to the controls and checks performed by the C-compiler.



However, in the event that a program requires very fast processing, the C language is impractical so the program must be carefully written in assembly language

Another point worth mentioning is the development environment, which is the part of the software that deals with the production and the modification of the source files.

### 5.3 INTRODUCING THE DEVELOPMENT TOOLS

The ST9+ Software Toolchain V6 allows complex applications to be developed easily and efficiently for the ST9+ family of microcontrollers. It is designed to provide the user with a powerful development environment which can be used to design, debug, maintain and develop applications in the C and assembly languages. In addition to the C compiler, assembler and linker, the ST9+ Software Toolchain V6 provides an Integrated Development Environment (IDE) that is used to edit, build and debug an application in a single environment.

Using the ST9+ Software Toolchain V6, it is possible to develop applications in the C language without being hindered by the segmented architecture of the ST9+ microcontroller. Applications can be as large as 4 MB of code and data, and can be completely written in C language as if developing standard C programs. This code is linked with the standard start-up code that initializes the ST9+ microcontroller. Depending on the application board, the startup files may need to be customized to ensure initialization.

With this software toolchain, variables can be handled in the ST9+ register file as if they were in memory, handling variables in this manner dramatically reduces the size of code. Objects in memory can be controlled either at a modular level or on an object by object basis. Thanks to the powerful features of the debugger, such as advanced breakpoints, break on registers, trace with 64K records and performance analysis, the debugging and tuning of an application is made easier and quicker.

The ST9+ Software Toolchain V6 is designed for use with the ST9 HDS2V2 emulators.

**To obtain further information about the toolchain, please refer to the toolchain documentation.**

## **5.4 PROGRAM CONFIGURATION AND INITIALISATION**

Most programs are divided into several source files. This makes modifications easier and re-compilation quicker, using the make utility that recompiles only the files that have changed since the last compilation.

How you split the source text into files is a matter of taste. However, a few rules are worth following for keeping things well organized. They are:

- For sake of portability, assembler source text must not be mixed with C source text in the same file. In actual practice, assembly statements may be written in C, but reduce these to a minimum.
- Code that is very low-level is very machine-dependent. This code should be in one or more specific files.

One or several higher levels of code can be defined according to the application. This is up to you, but in all cases, machine-specific code, even written in C, should not reside in the same file as a higher-level code. This is used to change the hardware configuration (assignments of the port pins, etc.) by changing only those files that are involved with low-level routines.

Once this layout is established, you can then write the files mentioned below. These files are used to configure the tools. Since they know the program structure, it can be maintained by compiling the right portions whenever they change. So you absolutely have to go through the following steps even though they are not directly related to writing code:

- Writing the makefile
- Writing the linker command file
- Writing the start-up file

These files are specific to each project and must be added to the list of source files. Examples are given in the applications described in this book and are available in the Companion software.

### **5.4.1 Writing the Makefile**

The makefile is the template that puts all the program pieces together. It describes the module interdependencies that enable the gmake utility to build the program efficiently by processing only those source files that have been modified since the last invocation of gmake<sup>(6)</sup>.

The Make language is very powerful, for a Make utility can be applied to almost any kind of processing where several files provide a single result. It is a generic machine that manages updates smartly. When developing programs for the ST9+, the makefile description is similar from one project to another. Most of the changes relate to the name and the number of the

<sup>(6)</sup> See GNU9P Make Utility Manual.

files involved. Thus, we propose here a skeleton makefile and we explain how you can tailor it for a specific application, without going into the advanced features gmake offers.

A skeleton makefile is given on the companion software, and a variant is included in the directory of each application. This will help you understand typical makefile usage, which is not difficult to learn.

The skeleton makefile reads as follows:

```
#!/***** /
#/*      MAKEFILE SKELETON      */
#!/***** /

# DEFINES
# *****

# Here you declare your compilation options
CFLAGS      = -m$(MODEL) -I$(INCDIR) -c -g -Wa,-alhd=$*.lis

# Here you declare your linking options
LDFLAGS     = -nostdlib -T$(SCRIPTFILE) -Wl,-Map,$(APPLI).map

# Define here the name of your application without any extension
APPLI      =

# Here you specify the memory model used by your application (compact/
#          specmed/medium)
MODEL      =

# Here you give the name of the script file used by your application
SCRIPTFILE =

# Give here the name of the C/SPP/ASM source files used in the application
C_SRC     =
SPP_SRC   =
ASM_SRC   =

# Give here the name of the startup files used in the application
```

```
STARTUP_SRC=

# List of directories to be searched
VPATH      =

# Location of include files. Do not leave this variable empty.
# If you do not need it, remove or comment it.
INCDIR     =

# COMMON DEFINES
# *****

# Name of file containing dependencies.
# This file is automatically generated by this Makefile
DEP        = $(APPLI).dep

# The gcc9 driver is used for running the compiler, assembler, linker
GCC        = gcc9

# List of object files
OBSJ       = $(patsubst %.spp,%o,$(filter %.spp,$(STARTUP_SRC))) \
             $(patsubst %.asm,%o,$(filter %.asm,$(ASM_SRC))) \
             $(patsubst %.spp,%o,$(filter %.spp,$(SPP_SRC))) \
             $(patsubst %.c,%o,$(filter %.c,$(C_SRC)))

# Rule for building the target
$(APPLI).u : $(OBSJ) $(LIBS) $(SCRIPTFILE)
            $(GCC) $(LDFLAGS) $(OBSJ) $(LIBS) -o $@

# Rules
%.o:%.c
    $(GCC) $(CFLAGS) $< -o $@

%.o:%.asm
    $(GCC) $(CFLAGS) $< -o $@
```

```

%.o:%.spp
    $(GCC) $(CFLAGS) $< -o $@

include $(APPLI).dep

# Rule for forcing the build without taking into account dependencies
rebuild:
    gmake -f $(APPLI).mak clean
    gmake -f $(APPLI).mak $(APPLI).u

# Rule for making dependencies file
$(DEP): $(C_SRC) $(SPP_SRC)
    @echo Generating dependencies ...
    $(GCC) -MM -I$(INCDIR) $^ > $@

# Rule for cleaning the application
.PHONY : clean
clean :
    @echo off
    if exist *.o del *.o
    if exist *.u del *.u
    if exist *.lis del *.lis
    if exist *.map del *.map
    if exist *.dep del *.dep
    if exist *.hex del *.hex

```

The syntax of this file looks complicated. In fact, you typically only have to change the DEFINES section. The various items of the file are detailed below.

#### 5.4.1.1 CFLAGS = -m\$(MODEL) -I\$(INCDIR) -c -g -Wa,-alh=\$\*.lis

CFLAGS is a variable that contains the options that govern the working of the C-compiler. Referring to the option table of the compiler, it means:

Option	Meaning
-m\$(MODEL)	Defines the memory model to use.

<code>-\${INCDIR}</code>	Defines user header files path.
<code>-c</code>	Output an object file for later linking.
<code>-g</code>	Include in the object file all necessary information for the debugger to allow it to use symbolic names.
<code>-Wa,-alhd=\${*.lis}</code>	Tells the gcc9 to transmit the option string <code>-alhd=\${*.lis}</code> to the assembler. These options makes the assemble generate the most complete assembly listing file to help finding problems more easily.

**5.4.1.2 LDFLAGS = -nostdlib -T\$(SCRIPTFILE) -WI,-Map,\$(APPLI).map**

LDFLAGS is a variable that contains the options that govern the working of the linker. The options are:

Option	Meaning
<code>-nostdlib</code>	Inhibits the use of standard startup files or libraries.
<code>-T\$(SCRIPTFILE)</code>	Tells the linker to use the specified script file.
<code>-WI,-Map,\$(APPLI).map</code>	Tells gcc9 to transmit the <code>-Map \$(APPLI).map</code> option string to the linker. This option will make the linker print a link map in the map file.

**5.4.1.3 APPLI = ...**

This variable must contain the name of the main object file and related files, which are:

File name	Type of file
<code>&lt;main file name&gt;.u</code>	Object file ready for loading into the emulator. This is defined in conjunction with the LD9 script file.
<code>&lt;main file name&gt;.map</code>	The memory map file name.

Example:

```
APPLI = SMCB
```

generates SMCB.U and SMCB.MAP using the script file to define the linker behavior.

**5.4.1.4 SCRIPTFILE = ...**

This variable must contain the name of the script file to be used during the linking process.

**5.4.1.5 C\_SRC = ...**

This variable must contain the complete list of the C source files involved in the program to be built. Example:

```
C_SRC = main.c config.c serial.c calcul.c encoder.c
```

**5.4.1.6 SPP\_SRC = ...**

This variable must contain the complete list of SPP source files involved in the program to be built. SPP are assembler source files needing preprocessing. Example:

```
SPP_SRC = register.spp decoder.spp
```

#### 5.4.1.7 ASM\_SRC = ...

This variable must contain the complete list of the assembler source files involved in the program to build. Example:

```
ASM_SRC = startup.asm interrup.asm
```

#### 5.4.1.8 STARTUP\_SRC = ...

This variable must contain the complete list of the startup files involved in the program to be built. Example:

```
STARTUP_SRC = crtbegin.spp crtend.spp
```

#### 5.4.1.9 VPATH = ...

This variable must contain the list of directories that the Make function should search. Example:

```
VPATH = ..\src ..\startup
```

#### 5.4.1.10 INCDIR = ...

This variable must contain the list of directories that contains header files needed by the program. Example:

```
INCDIR = ..\INCLUDE ..\HEADER
```

#### 5.4.1.11 Make Rules

A Make rule is a statement that both tells which file is dependent on which other file, and the processing needed in order to update the result file when the source file has changed.

All files written under MS-DOS are marked in the directory with a date/time stamp. This allows the Make utility to compare dates between files. If a file declared in a rule as being the result of a source file, and the source file has a later date than that of the result, the result must be regenerated. For example, in the following rule:

```
%.o:%.c
    $(GCC) $(CFLAGS) $< -o $@
```

The first line says that any file with extension .c is the source for the corresponding .o file, so that if the .c file is younger than the .o file, the source file must be recompiled.

The second line says that the compilation is done using GCC9, with the options stored in the CFLAGS variable, that the input file "\$<" is the .c file (source file), and the output file "\$@", specified by option -o, is the target file.

### 5.4.2 Writing the Linker Command File using a Script File

The linker uses the linker command file<sup>(7)</sup>(or Script File) to correctly position the code and variables in the memory spaces. It defines the start and end of the ROM and RAM area(s), and

gives the list of the object files to be linked. It also generates the appropriate labels to allow C variables to receive their initial values before the program starts.

Once the Script File is written, the only thing you have to do is to add new file names or change the mapping.

Below is an example of a generic script file for an ST90158:

```
MEMORY
{
  ROM_CODE_1 :ORIGIN = 0x000000, LENGTH = 64K, MMU = IDPR0 IDPR1 IDPR2 NO
  RAM1       : ORIGIN = 0x20F800, LENGTH = 2K, MMU = IDPR3
  REGFILE (t) : ORIGIN = 0x0F,  LENGTH = 192/* Groups 1 to 0x0C */
}

SECTIONS
{
  _stack_size = DEFINED(_stack_size) ? _stack_size : 0x100;

  .init :
  { *(.init) } > ROM_CODE_1

  .fini :
  { *(.fini) } > ROM_CODE_1

  .text :
  { *(.text) } >ROM_CODE_1

  > ROM_CODE_1

  .secinfo :
  { CREATE_SECINFO_TABLE } > ROM_CODE_1

  .rodata :
  { *(.rodata) } > ROM_CODE_1
```

(7) ST9+ Family GNU Software tools, Second Part: LD9.



```

.data : AT (LOADADDR(.rodata) + SIZEOF (.rodata))
{ *(.data) } > RAM1

.bss :
{ *(.bss) *(COMMON) } > RAM1

.stack :
{
  _stack_start = DEFINED( _stack_start ) ? _stack_start : . ;
  . = . + _stack_size ;
  _stack_end = _stack_start + _stack_size ; } > RAM1

.fardata : AT (LOADADDR(.data) + SIZEOF (.data))
{ *(.fardata) } > RAM1

.reg16_data : AT (LOADADDR(.fardata) + SIZEOF (.fardata))
{ *(.reg16_data) } > REGFILE

.reg16_bss :
{ *(.reg16_bss) } > REGFILE

.reg8_data : AT (LOADADDR(.reg16_data) + SIZEOF (.reg16_data))
{ *(.reg8_data) } > REGFILE

.reg8_bss :
{ *(.reg8_bss) } > REGFILE
}

```

For more details on the Command File, refer to the Command Language section in the GNU Software Tools User Manual.

### 5.4.3 Writing the Start-Up File

This file is the very first file executed at power on. It performs the initialisation procedure required for the processor to start. It differs according to whether the program includes modules written in C or not.

In all cases, it includes two main parts:

- The reset, exception and interrupt vectors.
- The initialisation code that is required for the program to start.

### 5.4.3.1 Vector Table

The vectors consist of the Reset vector, the Divide by zero vector and the other interrupt vectors. They are placed at defined addresses:

- The Reset vector must be located in the first word of the first segment.
- The Divide by zero trap must be placed at address 2 in each segment where a program uses division. Each segment containing programs using division must have its own Address trap branched to a local routine making only a "CALLS DIVIDE\_BY\_ZERO" far call to the Divide by zero service routine located in a single segment.
- All the other interrupt addresses must be placed in the Interrupt Segment. In "ST9+" mode, Interrupt Service Routines can make far calls to other segments.

They are organized as follows:

**Table 17. Segment 0**

Address	Cause	Point to
0	Reset (action on the reset pin, Watchdog reset or Software reset).	The start of the initialisation code. The reset address is the start-up address.
2	Divide by zero	Address of the routine in segment 0 that handles the case where a division by zero has occurred.

**Table 18. Segment n (not Interrupt Segment)**

Address	Cause	Point to
2	Divide by zero	Address of the routine in segment n that handles the case where a division by zero has occurred.

**Table 19. Interrupt Segment**

Address	Cause	Point to
2	Divide by zero	Address of the routine in segment ISR that handles the case where a division by zero has occurred.
4	Top level interrupt	The interrupt service routine for the top level interrupt.
...	Interrupt	Interrupt Service Routine addresses.

The vectors above are placed at these addresses by hardware. You can place the following ones at will, except that for each peripheral they must obey some rules like being a multiple of a given number, e.g. 8 for the SCI.

Address	Cause	Point to
n	First cause for the peripheral whose IVR is set to n	The routine that handles the first interrupt cause for that peripheral.

n+2	Second cause for the peripheral whose IVR is set to n	The routine that handles the second interrupt cause for that peripheral.
etc.		

To force the linker to effectively position these vectors from address zero, the start-up module must first be included in the module list in the linker command file.

### 5.4.3.2 Initialisation Code

The initialisation code mainly has to initialise the core. The core contains certain control registers that must be set to correct values or the program will fail to start. They are listed in the table below. They are in the order they are initialized in a typical start-up file, though this order is somewhat arbitrary.

Register Number	Register Name	Function(*)	Comments
235	MODER	Selects the space where the stacks reside (register file or memory), main clock divider on/off, clock prescaler division rate.	If power and electromagnetic interference are not a concern, the prescaler can be set to zero so that the processor runs at full speed. Otherwise, the speed/consumption trade-off can be handled at will according to the needs of the program.
231	FLAGR	Selects the single space of twin-space mode for the memory.	In the "ST9old" mode the DP bit of this register selects program memory when cleared, or data memory when set. It must be changed using the sdm and spm instructions. Typically, one of these is used at the beginning of the program and remains unchanged afterwards. On some occasions, it may be changed, for example to access tables of constants in ROM if two spaces are used. Therefore in "ST9+" mode, DP must be set with the sdm instruction (used only once in the start-up program) to set the use of DPR register to address data memory. The spm instruction must not be used. To access data through the CSR register, use the ldpd, lddp or ldpp instruction.
238-239	SSP	Position of the top of the system stack in memory or register file	No subroutine or function call may be performed before the initialisation of SSP and MODER. Note that since a call first decrements the stack pointer by two and then writes the return address, if the stack is positioned in the register file, it may be initialised to the register number of the top of stack + 1 to save stack space.

Register Number	Register Name	Function(*)	Comments
236-237	USP	Position of the top of the user stack in memory or register file. Unused if only one stack is used.	
232-233	RP0-RP1	Selects the mode for the working registers as well as the absolute register numbers for r0 and r8.	These registers are set using the srp, srp0 and srp1 instructions. See the description of working registers in Section 3.1.4.
230	CICR	Enables the MFTs, enables the interrupts, selects the arbitration mode (concurrent mode or nested mode), and the priority level of the main program.	<p>The GCEN bit of this register enables all the MFTs at once. It may also be set once the MFTs are all initialised, if it is desired that they be synchronised or that they do not start before the remainder of the program is ready.</p> <p>The IEN bit enables all the interrupts at once. Again, it may be set now, or only when the remainder of the program is ready to process them.</p> <p>The IAM bit selects either Concurrent Mode or Nested Mode. It is better to do it now.</p> <p>The three bits, CPL2 to CPL0, set the level of the main program. Its value depends on the structure of the program. Typically, it is set to 7, since the main program is likely to be the low-priority process. See the paragraph on interrupts in Section 3.4.</p>
234	PPR	Sets the page number for the paged register group; set to zero.	This register will probably be changed several times during the execution of the program. It is first set now, if the WCR needs to be initialised.
250 page 0	WDTPR	Prescaler register of the WatchDog Timer.	If the WDT is used as a watchdog <sup>(†)</sup> , it should be initialised before the WGEN bit is cleared in the WCR register below. In this case, it is advisable to initialise it right now. See note for values.
248-249 page 0	WDTHR+W DTLR	Reload register of the WDT.	Same note as above.

Register Number	Register Name	Function(*)	Comments
251 page 0	WDTCR	Mode control register of the WDT.	Same note as above.
252 page 0	WCR	Starts (or not) the watchdog function of the WDT, selects the wait states for external memory access independently for upper and lower memories.	If you use the Watchdog function, first initialise the Watchdog Timer. You can start it later using the WDGEN bit of this register, but no protection is on before this time. The external memory access is set by default to the maximum number of wait states to allow the program to start. You should reduce it to the exact number required by the type of memory to achieve maximum performance.

(\*) Some register functions may not be mentioned if not relevant for the initialisation.

(†) Device Datasheet; §9

Once you have set these registers, the core is in good shape to start work. The next task is to initialise the data memory and/or register file by entering a loop that writes zeroes into all locations used for data storage. This may seem superfluous, but there are two reasons for this:

- In C language, any non-initialized variable is supposed to contain zero as an initial value.
- In any case, this makes the program behavior reproducible, even if not all variables are initialized explicitly.

Then, the table of initial values for the initialized variable (in the C language sense) is copied to the location in RAM where the variables are positioned. The linker puts the initial values in the same order as the variables in RAM, so a mere block copy is sufficient for this initialisation.

Eventually, the entry point of the main program written in C or assembler can be called. The main program should be a closed loop and should not return. Typically in the start-up code, the call to the main routine is followed by a halt instruction.

### 5.4.3.3 Start-up File Customization

A generic start-up file is included with the Toolchain: crtbegin.spp. This file has to be modified in order to fit the needs of your application.

In most cases, only two parts should be modified: part 2 (interrupt vectors declaration) and part 6 (MMU setup).

**Note:** The start-up file initializes the "ST9old" mode (ENCSR bit of EMR2 to 0) to be compatible with the old ST9 version. In the main program you have to initialise this bit to 1 for "ST9+" mode if you want the MMU working with segments during interrupts.

### 5.4.3.3.1 Part 2: Interrupt Vector Declaration

```

/* +-----+
   | PART 2: INTERRUPT VECTOR DECLARATION |
   +-----+ */

; Interrupt vector definition
; Absolute address 0 is assumed (. == 0x0000)

.word __Reset ; address of reset routine

.word DIVIDE_BY_ZERO_TRAP_LABEL ; address of the divide by zero
; trap routine

.org 0x06
.word 0xffff ;no external watchdog used

.rept 126

.word __Default_Interrupt_Handler; default interrupt handler
; routine

.endr ; end of macro definition

```

The start-up file defines the reset vector and the divide by zero trap vector. All other vectors are directed to a default interrupt handler.

A new vector must be defined for each interrupt routine of the user program. The vector location must match the corresponding IVR register. Example:

```

.word __Reset ; address of reset routine

.word DIVIDE_BY_ZERO_TRAP_LABEL ; address of the divide by zero
; trap routine

.org 0x06
.word 0xffff ;no external watchdog used

.org 0x56

.word INTSCI_TransmitReady

```

```
.org 0x100
```

### 5.4.3.3.2 Part6: MMU setup

```
/* +-----+
| PART 6: MMU SETUP |
+-----+ */

#if defined(MEDIUM)
;
;   Initialisation of registers controlling external memory interface
;   EMR1 reset value is x000-000M
;   MC, DS2EN, ASAF, NMB, ET0, BSZ should be checked against user
;   memory configuration and EMR1 set accordingly
;
;   EMR2 reset value is M000-1111
;   ENCSR is 0, which selects ST9 compatibility mode for interrupt
handling.
;   DMESEL, PAS1, PAS0, DAS1 and DAS0 should be checked against user
memory
;   configuration and set complementary to WCR in page #0 (see below)
;   DPRREM is forced to one to have DPRi registers accessible in group E
;

    or    EMR2, #EMR2_dprrem        ; remap data page registers

;
;   Initialization of DPR registers with initial value
;

    ld    DPR0, #_idpr0
    ld    DPR1, #_idpr1
    ld    DPR2, #_idpr2
    ld    DPR3, #_idpr3
```

```
#else /* MEDIUM */

;
;   Initialization of DPR registers with initial value
;

    ld    DPR0_P, #_idpr0
    ld    DPR1_P, #_idpr1
    ld    DPR2_P, #_idpr2
    ld    DPR3_P, #_idpr3

#endif /* MEDIUM */

#if defined(MEDIUM) || defined (SPECMED)

;   ENCSR is 1, use CSR for interrupt handling.

    or    EMR2, #EMR2_encsr        ; enable csr during interrupts

#endif /* MEDIUM */

#if defined(COMPACT)

;   in compact programming model, the startup file
;   will assumes that CSR = ISR, set by the bootrom

#endif /* COMPACT */

.endproc
```

In this part, the user only needs to comment DPR register initialization lines if one or more DPRs does not map a memory region.



## 5.5 GLOBAL INITIALISATION: CORE AND PERIPHERALS

### 5.5.1 Core Initialisation

Set the lower program memory addresses to the addresses of the interrupt service routines that the peripherals will use.

Initialise the core, as shown above.

Initialise the PLL.

If the Multifunction Timers are to work synchronously, you must start them at the same time. To do this,

Reset the Global Counter ENable bit (GCEN, bit 7 of register CICR) before the MFTs are initialised.

Then set it just before the main program starts.

Initialise the memory. This may include:

Resetting the register file and/or the data memory to zero, and

Preloading the variables with the initial values.

The procedure to follow when programming in C is described above.

### 5.5.2 Peripheral Initialisation

It is now time to configure the peripherals. For each one, you must take the following steps:

Set the Page Pointer Register to the page that contains the peripheral's registers. On some peripherals, several pages are involved so set the Page Pointer Register accordingly.

Set the various registers that define the behavior of the peripherals. In some cases, you have to set them in a certain order. Refer to the appropriate Data Sheet. Do not yet set the bits that start the peripheral working.

Set the Interrupt Vector Register of each peripheral to point to the corresponding group of pointers to the interrupt service routines in program memory.

You can now set the Interrupt Mask Register, since the global Interrupt ENable bit is reset.

If you are using DMA, set the DAPR and DCPR registers to point to two registers in the register file. Then:

- Initialise the address register to the address of the buffer in which the data is to be stored.
- Set the counter register to zero to inhibit DMA transfers.

You can now set the peripheral Enable bit or Start bit, unless you only want it to start later (as can be the case with the Watchdog Timer).

### 5.5.3 Port Initialisation

When you have configured all the peripherals as described above, you should initialise the ports to your requirements: input or output, open drain or push-pull, TTL or CMOS levels, etc. for the parallel I/O ports.

You must set the port pins that serve as inputs or outputs for peripherals as either:

- Alternate Function for peripheral outputs, or
- Regular Input for peripheral inputs

The exception is the A/D converter, where you must set the input pin as Alternate Function.

### 5.5.4 Final Initialisation

Install the Working Registers in the group defined for the main program.

Set the Page Pointer Register to a default value.

Set the Global Counter Enable, the global Interrupt ENable and, if required the Watchdog function.

The main program is now ready to run.

## 5.6 INTERRUPT CONSIDERATIONS

The ST9+ has two main paging registers:

- The RPP register pair that selects the working register group
- The PPR register that selects one of 256 pages within register group 15

These registers are essential to the correct working of the program.

When an interrupt occurs, it is likely you will have to change either or both of these registers. This is why you must push them to the stack on entry, and pop them back on exit.

An interrupt is requested by a bit in a register of a peripheral. This bit is not reset automatically by the fact that the interrupt is serviced. You must reset it in the code of your interrupt service routine.

If you write an interrupt service routine in C, by default PPR and all registers used by the routine are pushed on the stack. This can be time-consuming. If your program is entirely written in C, and you use none or few registers explicitly, the register file has enough room to allocate a private working register group for each interrupt service routine. You specify this by a `#pragma` pseudo-instruction. This method provides the fastest response times.

## 6 DETAILED BLOCK DIAGRAMS

Here are the detailed block diagrams to supplement to the simplified ones used at various points throughout this book.

## 6.1 EXTERNAL INTERRUPT CONTROLLER

Figure 46. External Interrupt Block Diagram

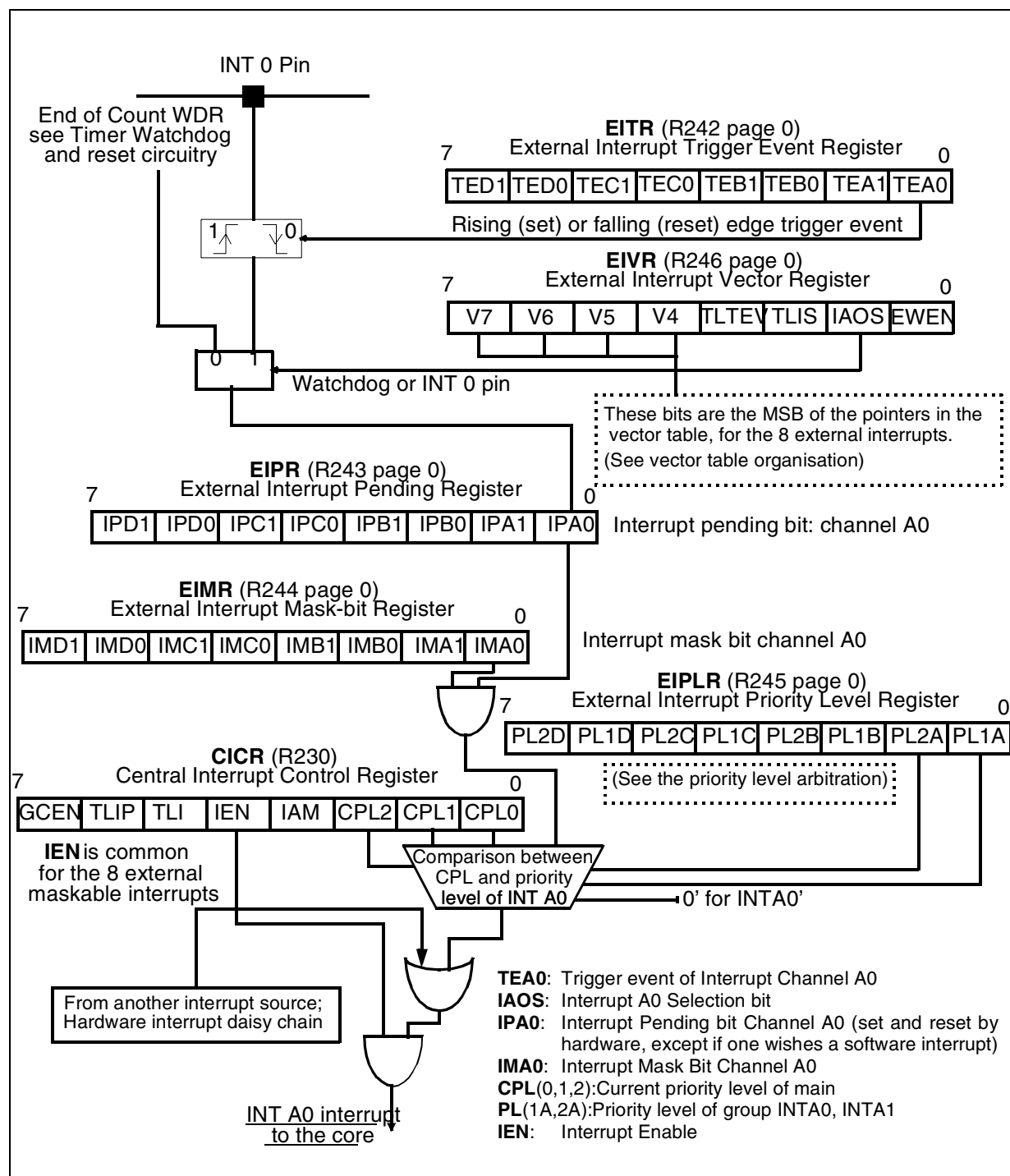



6.3 WATCHDOG TIMER

Figure 48. Watchdog Timer Block Diagram

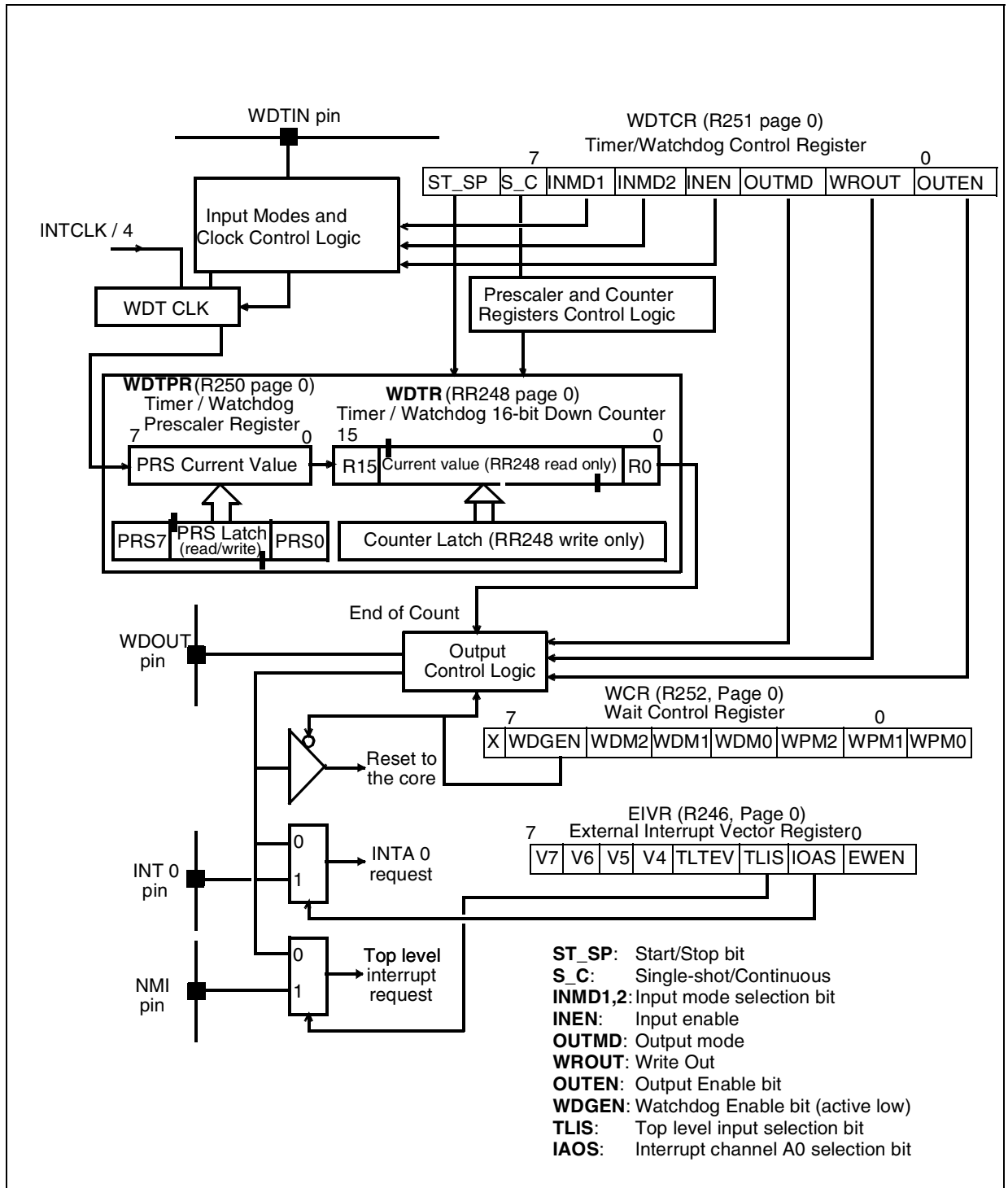

6.4 MULTIFUNCTION TIMER

Figure 49. Multifunction Timer Block Diagram

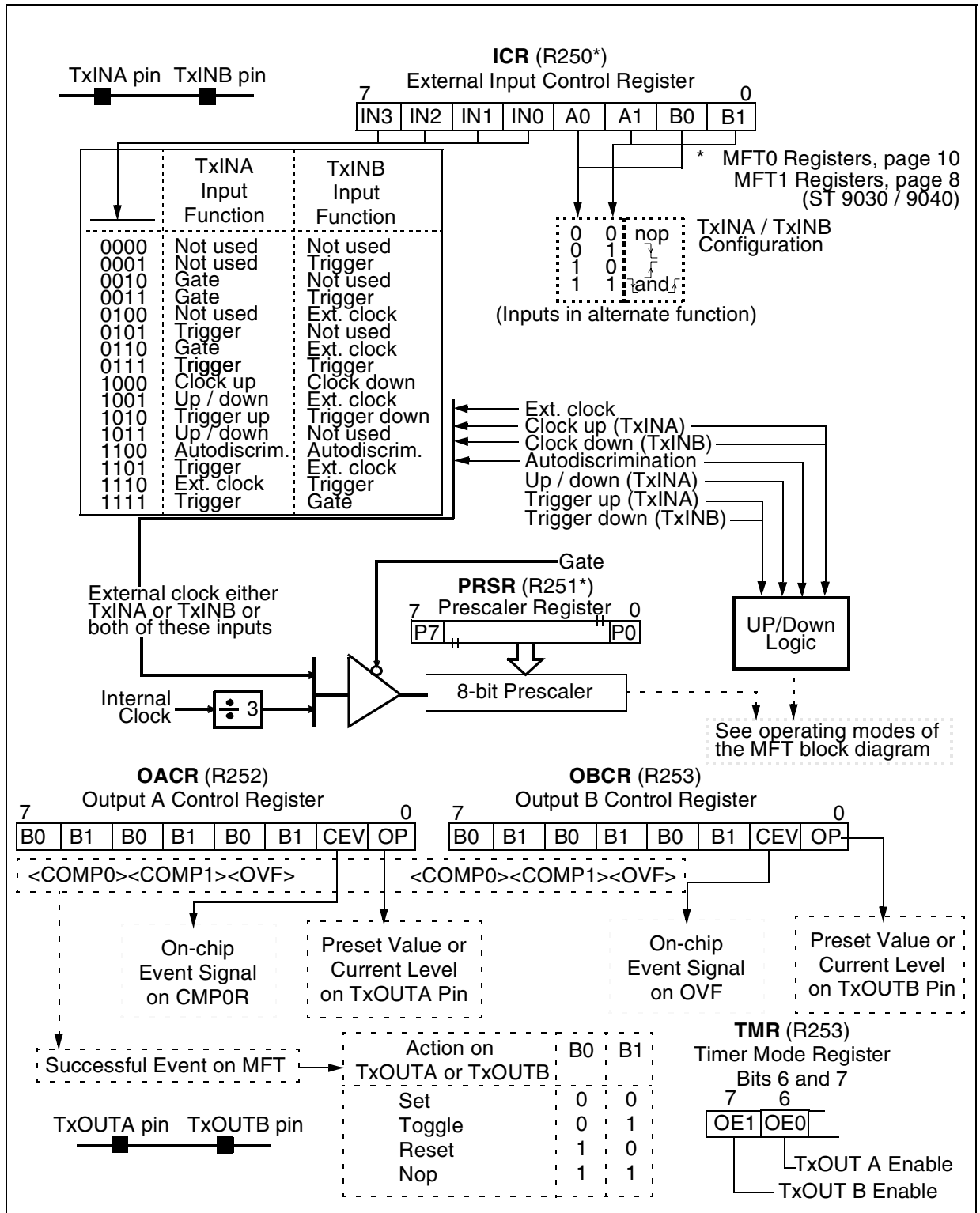

Figure 50. MFT Operating Modes Block Diagram

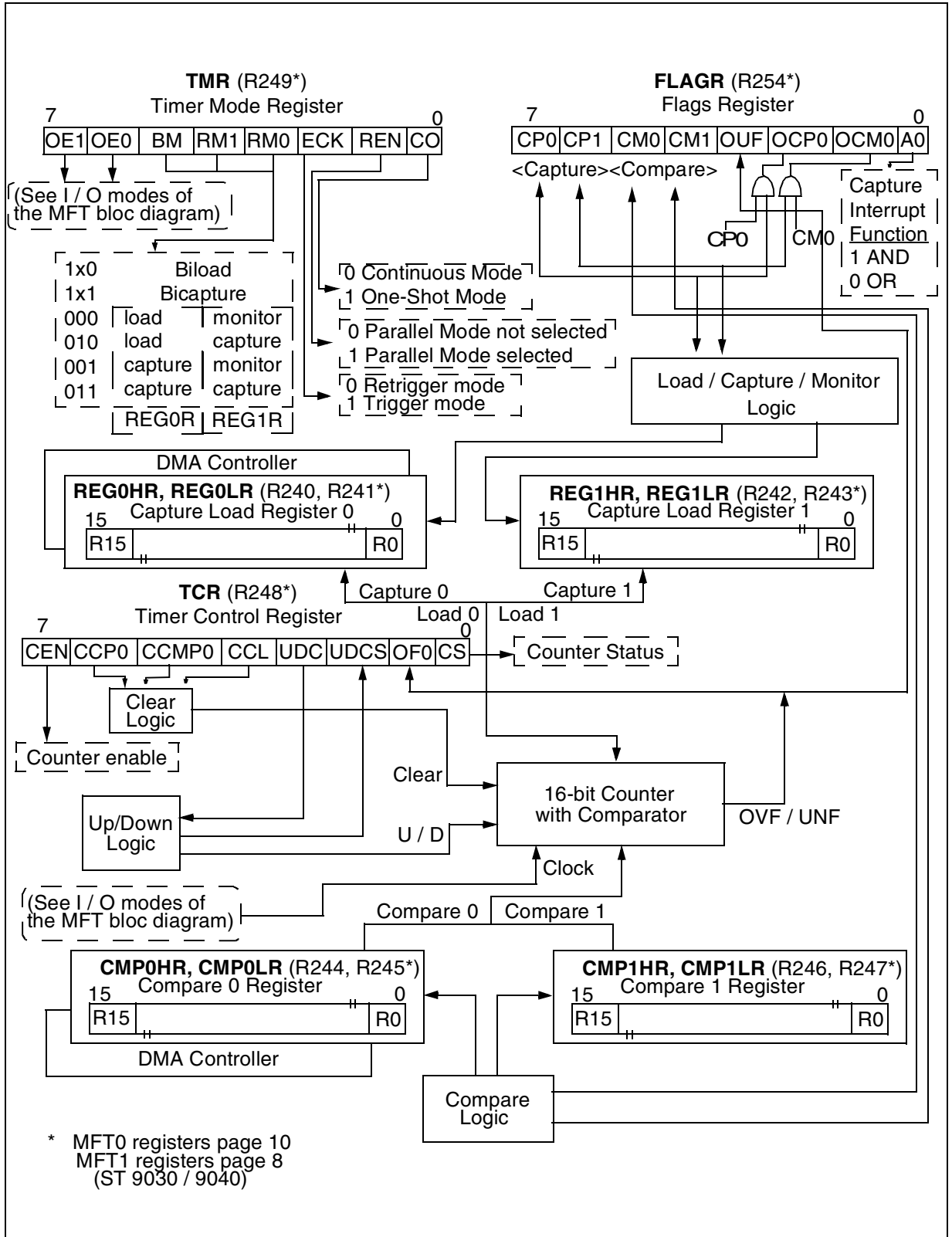
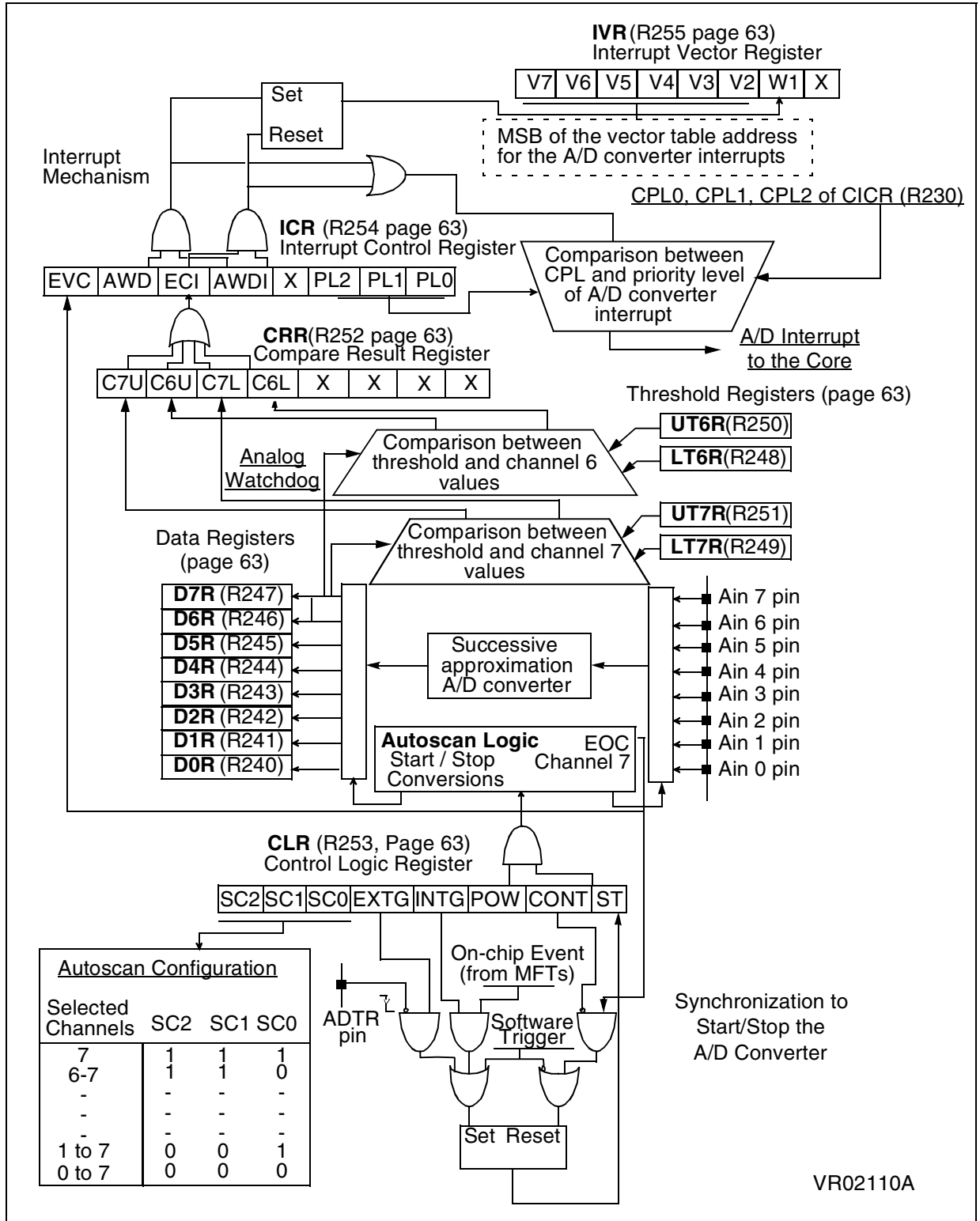

Figure 51. Analog to Digital Converter Block Diagram



VR02110A



## 7 GLOSSARY

### A

A/D	Analog to Digital
AC	Alternating Current
ACR	Address Compare Register
ADC	Analog to digital converter
ADTR	A/D Trigger
AIN	Analog input
AWD	Analog watchdog

### B

BRG	Bit Rate Generator
-----	--------------------

### C

CCU	Clock Control Unit
CHCR	Character Configuration Register
CICR	Central Interrupt Control Register
CLK	Clock
CLR	Control Logic Register
CMOS	Complementary Metal Oxide Silicon
CMP	Compare Register
CPL	Current Priority Level
CR	Carriage Return
CRR	Compare Results Register
CS	Chip Select

### D

DAPR	DMA Address Pointer Register
DC	Direct Current
DCPR	DMA Counter Pointer Register

DI	Data In
DIL	Dual In line
DMA	Direct Memory Access
DO	Data Out
DP	Data Page

**E**

ECV	End of conversion
EEPROM	Electrically-Erasable PROM
EIMR	External Interrupt Mask-Bit Register
EIPLR	External Interrupt Priority Level Register
EIPR	External Interrupt Pending Register
EITR	External Interrupt Trigger Register
EIVR	External Interrupt Vector Register
EWDS	Erase or Write Disable
EWEN	Erase or Write Enable

**F**

FLAGR	Flag Register
-------	---------------

**G**

GCC9	GNU C Compiler for ST9+
------	-------------------------

**I**

I/O	Input/Output
IAM	Interrupt Arbitration Mode
ICR	External Input Control Register
IDCR	Interrupt/ DMA Control Register
IDMR	Interrupt/ DMA Mask Register
IDPR	Interrupt/DMA Priority Register

---

IEN	Interrupt Enable
INMD	Interrupt Mode
INT	Interrupt
IOCR	I/O Connection Register
ISR	Interrupt Segment Register or Interrupt Service Routine
IVR	Interrupt Vector Register

**L**

LCD	Liquid Crystal Display
LED	Light Emitting Diode
LF	Line Feed
LSB	Least Significant Bit

**M**

MFT	Multifunction Timer
MMU	Memory Management Unit
MODER	Mode Register
MSB	Most Significant Bit

**N**

NICR	Nested Interrupt Control Register
NMI	Non-Maskable Interrupt

**O**

OACR	Output A Control Register
OBCR	Output A Control Register
OVF	Overflow

**P**

PC	Program Counter or Personal Computer
PFE	Programmer's File Editor
PPR	Page Pointer Register

PRL	Priority Level
PROM	Programmable ROM
PWM	Pulse Width Modulator
PXC	Port Control Register
PXDR	Port Data Register

**R**

RAM	Random Access Memory
RCCU	Reset and Clock Control Unit
ROM	Read-Only Memory
RPP	Working Register Pointer
RXCLK	Receiver Clock Input
RXDATA	Receiver Data

**S**

SEG	Extract the 6 bits segment of a label
SCI	Serial Communications Interface
SCK	Serial Clock
SOF	Extract the 16 bits offset of a label
SPI	Serial Peripheral Interface
SPICR	SPI Control Register
SPIDR	SPI Data Register
SRP	Set Register Pointer
SSPR	System Stack Pointer Register

**T**

TCR	Timer Control Register
TLNM	Top Level Not Maskable
TMR	Timer Mode Register
TTL	Transistor to Transistor Logic

TXCLK      Transmitter Clock Input

TXD        Transmitter Data

## U

U/D        Up/Down

UART      Universal Asynchronous Receiver/Transmitter

UNF        Underflow

USPR      User Stack Pointer Register

UV         Ultraviolet

## W

WDT        Watchdog Timer

WDTCR     Watchdog Timer Control Register

WDTLR     Watchdog Timer Low Register

WDTPR     Watchdog Timer Prescaler Register

# Index

## 8 INDEX

### A

ADC	
configuring the input pin .....	59
detailed block diagram .....	128
interrupt vectoring.....	92
Address spaces	
overview .....	10
Addressing modes.....	37
Analog watchdog	
overview .....	92
Arguments	
passing arguments in C .....	35
Arrays	
accessing .....	37
AWD bit .....	92

### B

Bit rate generator.....	85
Block copy .....	37

### C

Causes	
interrupt causes .....	39
C-compiler .....	104
CCU	
Clock Control Unit .....	53
Character matching	
SCI .....	85
CICR	
overview .....	42
Clock selection	
MFT.....	67
Compare Result Register.....	92
Concurrent mode.....	43
interrupts .....	42
Context switching .....	13, 122
Continuous mode	
WDT .....	63
WDT example .....	65

Control registers	
example of programming .....	57
Copy	
block copy .....	37
Core	
overview .....	6, 10
CPL	
overview .....	42
CPUCLK	
CPU clock .....	53
CSR	
Code Segment Register.....	20

### D

DCPR .....	52
Development tools .....	104
overview .....	105
Divide instructions .....	32
DMA	
using in conjunction with the UART 85	
DMA controller	
application.....	84
overview .....	50
DMASR	
DMA Segment Register .....	23
Driver	
I/O .....	59

### E

ECV bit .....	92
Emulator.....	104
Enable	
interrupt enable flag .....	43
Event counter mode	
WDT.....	61
Examples	
context switching .....	13
divide instructions.....	32
DMA application .....	84
interrupt initialisation .....	65
interrupt routine.....	50
IVR .....	39
LCD interface .....	80

---

# Index

---

makefile .....	107
MFT initialisation.....	77
MFT interrupt vector.....	40
nested interrupts.....	44
parameter passing in C .....	35
periodic interrupt timer application ..	64
programming peripheral control registers.....	57
programming peripheral registers ..	57
PWM application.....	74
PWM output.....	71
selecting a register page .....	18
test and jump.....	34
test under mask .....	31
Extract the page number of a data.....	25

---

## F

---

FLAGR register .....	115
----------------------	-----

---

## G

---

Gated input mode	
WDT .....	61
GNU9 .....	104
Groups	
register groups.....	12

---

## I

---

I/O pins .....	59
I/O port	
configuration registers .....	59
IEN bit.....	43, 48
Include files	
peripheral register definition .....	58
Initialisation	
global .....	121
MFT example .....	77
stacks .....	27
WDT .....	65
Initialisation code .....	115
Instruction set	
overview .....	29
INTCLK	

Peripheral clock.....	53
Interrupts	
ADC .....	92
analog watchdog .....	92
causes .....	39
concurrent mode .....	42, 43
context switching.....	122
CPL.....	42
enable flag (IEN) .....	43
external interrupt vectors .....	50
external interrupts block diagram ...	47
external, detailed block diagram... ..	123
initialisation example.....	65
interrupt routine	
example .....	50
nested mode .....	42, 43
pins .....	46
priorities.....	41
SCI interrupt vectors .....	89
system overview .....	37
top-level interrupt .....	47
vectors.....	38

## ISR

Interrupt Segment Register .....	23
----------------------------------	----

## IVR

example.....	39
--------------	----

---

## J

---

## Jump

test and jump.....	34
--------------------	----

---

## L

---

## Latency

interrupt latency .....	41
LCD interface example .....	80
Load instructions .....	29
Look-up tables	
implementing.....	34

---

## M

---

Make file example .....	107
Make utility.....	104, 106

# Index

Mask register		
interrupt and DMA mask register....	70	
Masking		
external interrupts.....	46	
Memory spaces		
overview .....	10	
MODER register .....	27, 115	
Moving data blocks .....	29	
Multifunction timer		
detailed block diagram .....	126	
initialisation example.....	77	
interrupt and DMA mask register....	70	
interrupt vector example.....	40	
operating modes detailed block diagram		
127		
PWM example.....	71	
swap mode .....	53	
Multiplexing		
pins.....	49	
<hr/>		
<b>N</b>		
<hr/>		
Nested mode .....	42, 43	
example.....	44	
NMI.....	42, 46, 47	
<hr/>		
<b>P</b>		
<hr/>		
PAG .....	25	
Parallel I/O .....	59	
Parameter passing		
C language example.....	35	
Periodic interrupt application .....	64	
Peripheral register pages.....	12	
Peripherals		
control registers programming example		
57		
list of main.....	7	
overview .....	57	
programming control registers .....	57	
register definition include files.....	58	
Pins		
external interrupts.....	46	
I/O pins .....	59	
multiplexing.....	49	
WDT output pin.....	63	
POF		
extract the offset of the data address.	25	
Pointers		
register pointers.....	12	
stack pointer .....	27	
Port		
initialisation .....	122	
Prescaler register		
MFT.....	67	
Priority		
assigning to interrupt source .....	42	
external interrupts .....	46	
interrupt priorities.....	41	
interrupt priority mechanism .....	37	
top-level interrupt.....	47	
Processor core.....	6, 10	
PWM		
application example .....	71	
PWM application example .....	74	
<hr/>		
<b>R</b>		
<hr/>		
RCCU		
Reset and Clock Control Unit.....	53	
Realtime programming .....	41	
Register		
peripheral pages.....	12	
Register file		
overview .....	11	
Register numbers table .....	15	
Register page number table .....	17	
Register-oriented machine		
definition of .....	7	
Register-oriented programming model		
overview .....	10	
Registers		
definition include files .....	58	
groups .....	12	
page selection example .....	18	
pointers .....	12	
working.....	11, 12	
Retriggerable input mode		
WDT.....	62	



---

# Index

---

---

## S

---

SCI	
theory of operation .....	85
SEG	
Extract the 6 bits segment of a label	20
Serial communication interface	
overview .....	84
Serial peripheral interface	
interrupt vectors .....	89
overview .....	79
Single mode	
WDT .....	63
SOF	
Extract the 16 bits offset of a label	20
Sources	
interrupt sources .....	39
Srp instruction .....	13
SSP .....	115
ST9040 block diagram .....	8
ST90R540 block diagram .....	8, 9
Stack	
overview .....	26
Stacks	
initialisation .....	27
locating stack pointer in register .....	27
location options .....	28
Start-up file .....	113
Structures	
accessing .....	37
Swap mode	
multifunction timer .....	53
Switching	
working registers .....	13

---

## T

---

Test and jump .....	34
Test under mask .....	30
Timer	
block diagram .....	60
event counter mode .....	61

gated input mode .....	61
output pin .....	63
retriggerable input mode .....	62
single/continuous mode .....	63
triggerable input mode .....	62
TLNM bit .....	47
Tools .....	104
Top-Level interrupt .....	47
block diagram .....	48
detailed block diagram .....	124
Triggerable input mode	
WDT .....	62

---

## U

---

UART application .....	84
USP .....	116

---

## V

---

Vector table .....	114
Vectors	
example with MFT .....	40
external interrupts .....	50
interrupt vectors overview .....	37

---

## W

---

Watchdog	
analog .....	92
Watchdog timer .....	46, 47
detailed block diagram .....	125
output pin .....	63
overview .....	60
WDT	
initialisation example .....	65
periodic interrupt application .....	64
Working registers	
example .....	13
overview .....	11, 12
register pointers .....	12
switching .....	13

### NOTES:

Information furnished is believed to be accurate and reliable. However, STMicroelectronics assumes no responsibility for the consequences of use of such information nor for any infringement of patents or other rights of third parties which may result from its use. No license is granted by implication or otherwise under any patent or patent rights of STMicroelectronics. Specifications mentioned in this publication are subject to change without notice. This publication supersedes and replaces all information previously supplied. STMicroelectronics products are not authorized for use as critical components in life support devices or systems without the express written approval of STMicroelectronics.

The ST logo is a registered trademark of STMicroelectronics

©2000 STMicroelectronics - All Rights Reserved.

Purchase of I<sup>2</sup>C Components by STMicroelectronics conveys a license under the Philips I<sup>2</sup>C Patent. Rights to use these components in an I<sup>2</sup>C system is granted provided that the system conforms to the I<sup>2</sup>C Standard Specification as defined by Philips.

STMicroelectronics Group of Companies

Australia - Brazil - China - Finland - France - Germany - Hong Kong - India - Italy - Japan - Malaysia - Malta - Morocco - Singapore - Spain  
Sweden - Switzerland - United Kingdom - U.S.A.

<http://www.st.com>