



Microtips Technology Inc.

台北縣汐止鎮康寧街169巷31號12樓
12F, No 31, Lane 169, Kang Ning St.
Hsi-Chih, Taipei Hsien, Taiwan, R.O.C.

WEB : <http://www.microtips.com.tw>
E-mail : Macros@microtips.com.tw
TEL: 886-2-2695-3133 FAX :886-2-2695-8625

LCD MODULE SPECIFICATION FOR CUSTOMER'S APPROVAL

CUSTOMER : Standard

MODULE TYPE : MTG-S12864ARGNS

APPROVED BY: (FOR CUSTOMER USE ONLY)

Approved By	Checked By	Prepared By	MT File No	Date Issued

CONTENTS

ITEM	PAGE
FEATURES	3
LCD MODULE DRAWING	4
GENERAL SPECIFICATION	5
ABSOLUTE MAXIMUM RATING	5
ELECTRICAL CHARACTERISTIC	6
OPTICAL CHARACTERISTIC	6
MECHANICAL SPECIFICATION	7
INTERFACE PIN ASSIGNMENT	8
BLOCK DIAGRAM	11
POWER SUPPLY DIAGRAM	11
TIMING CHARACTERISTICS	12
DISPLAY COMMANDS	14
MEMORY MAPPING	15
ADDRESS CONFIGURATION OF DISPLAY DATA RAM	16
RELIABILITY TEST	17
APPEARANCE CHECK	17
HANDLING PRECAUTIONS	18
LCD PRODUCT QUALITY STANDARD	19
REVISION HISTORY	20

SPECIFICATION FOR
LIQUID CRYSTAL DISPLAY MODULE
MODEL NO. : MTG-S12864ARGNS

View Direction	<input checked="" type="checkbox"/> 6 O'clock		<input type="checkbox"/> 12 O'clock		
LCD Type	<input type="checkbox"/> FSTN Positive		<input type="checkbox"/> FSTN Negative		
	<input checked="" type="checkbox"/> STN Gray	<input type="checkbox"/> STN Yellow Green	<input type="checkbox"/> STN Blue		
Rear Polarizer	<input checked="" type="checkbox"/> Reflective	<input type="checkbox"/> Transflective		<input type="checkbox"/> Transmissive	
Backlight Type	<input type="checkbox"/> LED	<input type="checkbox"/> EL	<input type="checkbox"/> Internal Power		<input type="checkbox"/> 5V input
		<input type="checkbox"/> CCFL	<input type="checkbox"/> External Power		<input type="checkbox"/> 24V input
Backlight Color	<input type="checkbox"/> White	<input type="checkbox"/> Amber	<input type="checkbox"/> Blue Green	<input type="checkbox"/> Yellow Green	<input type="checkbox"/> Other
Temperature Range	<input checked="" type="checkbox"/> Normal		<input type="checkbox"/> Wide		<input type="checkbox"/> Super Wide
EL Driver IC	<input type="checkbox"/> Build-in		<input checked="" type="checkbox"/> Not Build-in		
DC-to-DC	<input type="checkbox"/> With		<input checked="" type="checkbox"/> Without		

TO BE VERY CAREFUL !

The LCD driver ICs are made by CMOS process, which are very easy to be damaged by static charge, make sure the user is grounded when handling the LCM.

REV.	DESCRIPTION	DRAWN	CHECK	APP'D	DATE

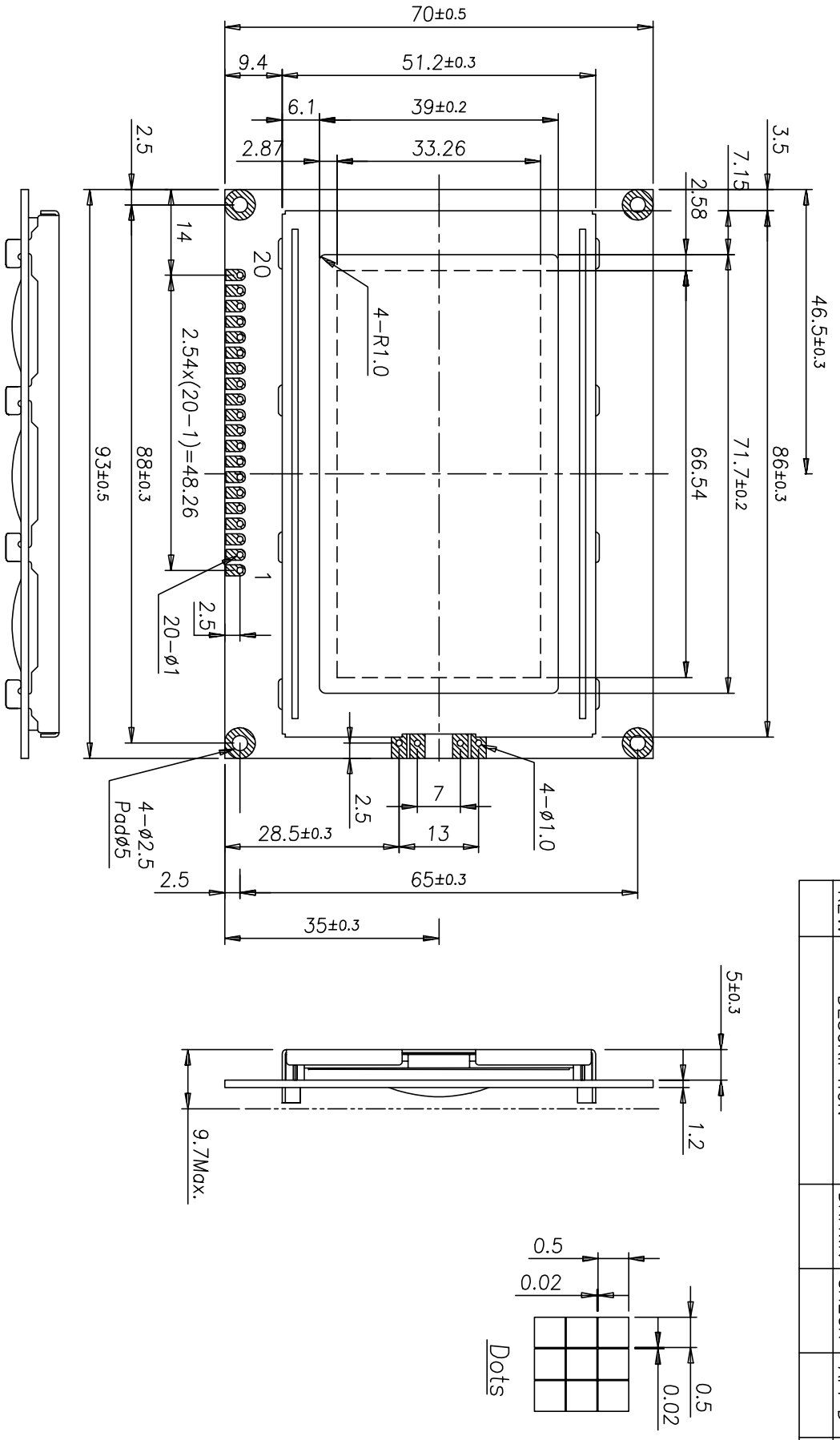

PIN ASSIGNMENT

1.	VSS	5.	R/W	9.	DB2	13.	DB6	17.	RST
2.	VDD	6.	E	10.	DB3	14.	DB7	18.	VEE
3.	V0	7.	DB0	11.	DB4	15.	CS1	19.	BKL1
4.	D/I	8.	DB1	12.	DB5	16.	CS2	20.	BKL2

NO.	M-12864A	Q'TY	1	DATE:	4-28-99'	MATERIAL	---	FINISH	---
PART NAME		APP'D		UNIT:MM		SCALE: 1/1		PRODUCT: MTC-12864A	
DRAWN		CHECK				UNLESS OTHERWISE SPECIFIED TOLERANCE ON FRACTIONS DECIMALS ANGLES 0.10 0.5°		DWG NO.:	G12864A0
								FILE:	DWG\MTC128\G12864A
								SHEET	1 / 1
								Rev:	A



GENERAL SPECIFICATION

Item	Content
Display Resolution	128(W)× 64(H)
Dimensional Outline(mm)	93.0(W)× 70.0(H)× 9.7 max(D)
Display mode	Reflective Type/ Positive Display
Circuit	Common-Driver IC, Segment-driver IC with build-in SRAM
Interface	Data (D0~D7), D/I, R/W, E, RST, CS1, CS2, V _{EE} , V _{ADJ}

ABSOLUTE MAXIMUM RATING

(1) Electrical Absolute Ratings

Item	Symbol	Min.	Max.	Unit	Note
Power Supply for Logic	V _{DD} -V _{SS}	-0.3	6.5	Volt	
Power Supply for LCD	V _{DD} -V _{EE}	-0.3	19.0	Volt	
Input Voltage	V _I	-0.3	V _{DD}	Volt	
Supply Current for LED backlight	I _{LED}	-	780	mA	

(2) Environmental Absolute Maximum Ratings

Item	Normal Temperature				Wide Temperature			
	Operating		Storage		Operating		Storage	
	Max,	Min.	Max,	Min.	Max,	Min.	Max,	Min.
Ambient Temperature	0°C	+50°C	-20°C	+70°C	-20°C	+70°C	-30°C	+80°C
Humidity(without condensation)	Note 2,4		Note 3,5		Note 4,5		Note 4,6	

Note 2 Ta ≤ 50°C : 80% RH max

Ta > 50°C : Absolute humidity must be lower than the humidity of 85%RH at 50°C

Note 3 Ta at -20°C will be <48hrs at 70°C will be <120hrs when humidity is higher than 75%.

Note 4 Background color changes slightly depending on ambient temperature. This phenomenon is reversible.

Note 5 Ta ≤ 70°C : 75RH max

Ta > 70°C : absolute humidity must be lower than the humidity of 75%RH at 70°C

Note 6 Ta at -30°C will be <48hrs, at 80 °C will be <120hrs when humidity is higher than 75%.

ELECTRICAL CHARACTERISTICS

Item	Symbol	Condition	Min.	Typ	Max.	Unit	note
Power Supply for Logic	$V_{DD}-V_{SS}$	-	4.5	5.0	5.5	Volt	-
Input Voltage	V_{IL}	L level	V_{SS}	$0.2 V_{DD}$	-	Volt	-
	V_{IH}	H level	$0.8 V_{DD}$	V_{DD}	-	Volt	-
LCM Recommend LCD Module Driving Voltage	$V_{DD}-V_O$	$T_a=0^{\circ}C$	9.3	9.0	9.3	Volt	-
		$T_a=25^{\circ}C$	8.4	8.7	9.0		
		$T_a=50^{\circ}C$	7.7	7.92	8.2		
Power Supply Current for LCM	I_{DD} (LED B/L OFF)	$V_{DD}=5.0V$ $T_a=25^{\circ}C$ $V_{DD}-V_O=8.7V$ $V_{LED}=4.2V$	-	1.5	1.8	mA	-
	I_{EE}		-	0.6	1.0		
	I_{LED} (LED B/L ON)		-	390	585		
Power Supply for Backlight	V_{LED}	$T_a=25^{\circ}C$	-	4.2	-	V DC	-
	V_{EL}		-	100VAC /400 Hz	-	VAC	

OPTICAL CHARACTERISTICS

Item	Symbol	Condition	Min.	Typ	Max.	Unit	note
Viewing angle range	θ_f (12 o'clock)	When $Cr \geq 2$	-	35	-	Degree	9,10
	θ_b (6 o'clock)		-	45	-		
	θ_l (9 o'clock)		-	30	-		
	θ_r (3 o'clock)		-	30	-		
Rise Time	T_r	$V_{DD}-V_O=8.7V$ $T_a=25^{\circ}C$		110	165	mS	
Fall Time	T_f			250	300		
Contrast	Cr		-	5.34	-		

MECHANICAL SPECIFICATION

Product No.		MTG-S12864ARGNS
Module Size		93.0(W)× 70.0(H)× 9.7 max(D)
Dot Size		0.50(W)mm× 0.50(H)mm
Dot Pitch		0.52(W)mm× 0.52(H)mm
Resolution		128(W)× 64(H) Dots Matrix
Duty Ratio		1/64 Duty
LCD Display Mode	STN	<input checked="" type="checkbox"/> Gray Mode <input type="checkbox"/> Yellow Mode <input type="checkbox"/> Blue Mode
	FSTN	<input type="checkbox"/> Black & White(Normally White/Positive Image) <input type="checkbox"/> Black & White(Normally White/Negative Image)
	Rear Polarizer:	<input checked="" type="checkbox"/> Reflective <input type="checkbox"/> Transflective <input type="checkbox"/> Transmissive <input type="checkbox"/> Transflective(High Transmissive)
Viewing Direction		<input checked="" type="checkbox"/> 6 O'clock <input type="checkbox"/> 12 O'clock <input type="checkbox"/> 3 O'clock <input type="checkbox"/> 9 O'clock
Backlight		<input checked="" type="checkbox"/> W/O <input type="checkbox"/> CCFL <input type="checkbox"/> EL <input type="checkbox"/> LED
Controller		KS0108 or compatible
DC/DC Converter		Without (Optional)
EL Driver		Without

INTERFACE PIN ASSIGNMENT

Pin No.	Pin Out	I/O	Description
1	V _{SS}	-	GND
2	V _{DD}	-	Logic supply voltage
3	V _O	-	Power supply for LCD panel, tuning from V _{DD} -V _{EE}
4	D/I	I	Data/Instruction D/I=high : Indicates that data of DB0~DB7 is display data. D/I=low : Indicates that data of DB0~DB7 is instruction.
5	R/W	I	Read/Write R/W=high : Data of DB0~DB7 can be read by CPU. R/W=low : Data of DB0~DB7 can be written into LCD driver IC at the falling edge of E when CS1 and CS2 is high.
6	E	I	Enable When write(R/W=low) : Data of DB0~DB7 is latched at the fall of E When read(R/W=high) : Data is read while E is at high level.
7 14	DB0 DB7	I/O	Data bus. 3-state I/O common terminal.
15	CS1	I	Chip-select for the left half of the display. Active high.
16	CS2	I	Chip-select for the right half of the display. Active high.
17	RES	I	Setting the RES signal to Low level can initialize the following registers. 1. ON/OFF register 0 set(Display off) 2. Display start line register 0 set(display starts from line 0) After releasing reset, this condition can be changed only by software.
18	V _{EE}	-	Power supply for LCD driving circuit. Please refer page 11 for DC-to-DC connecting
19	BKL _A	-	Power supply for backlight. (4.2V/390~585 mA DC for LED backlight, 110V/400Hz AC for EL)
20	BKL _K	-	

JUMPER EXPLANATION:

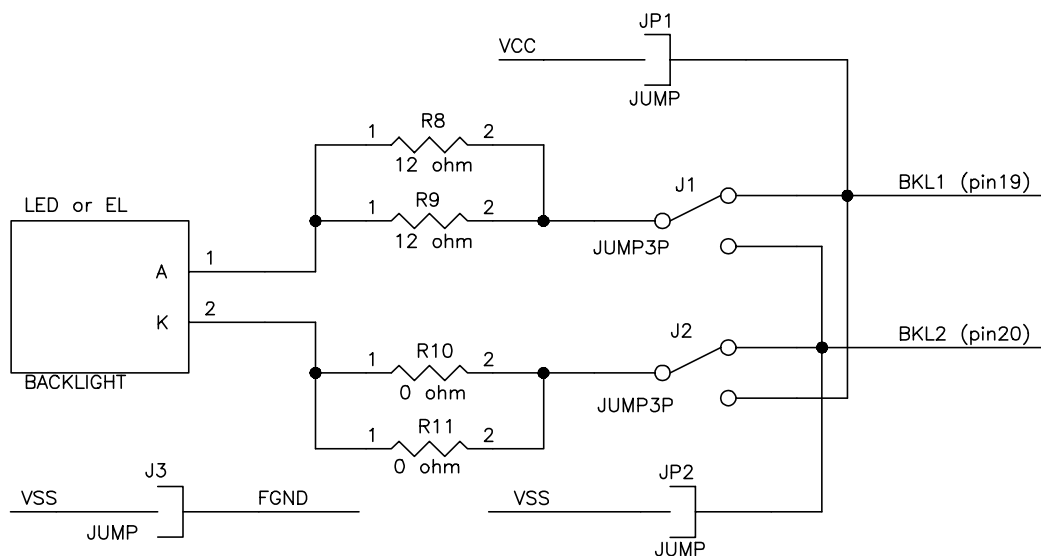

[Note 7] Definition of Operation Voltage (Vop)

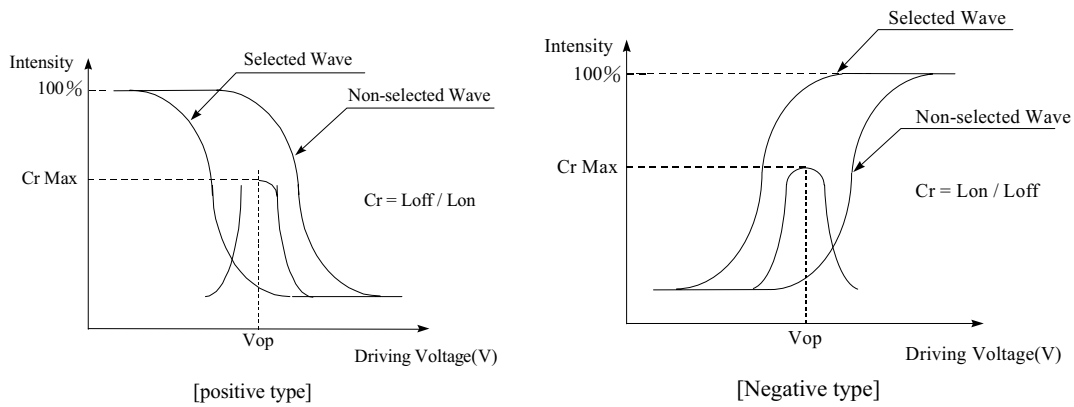

[Note 8] Definition of Response Time (Tr, Tf)

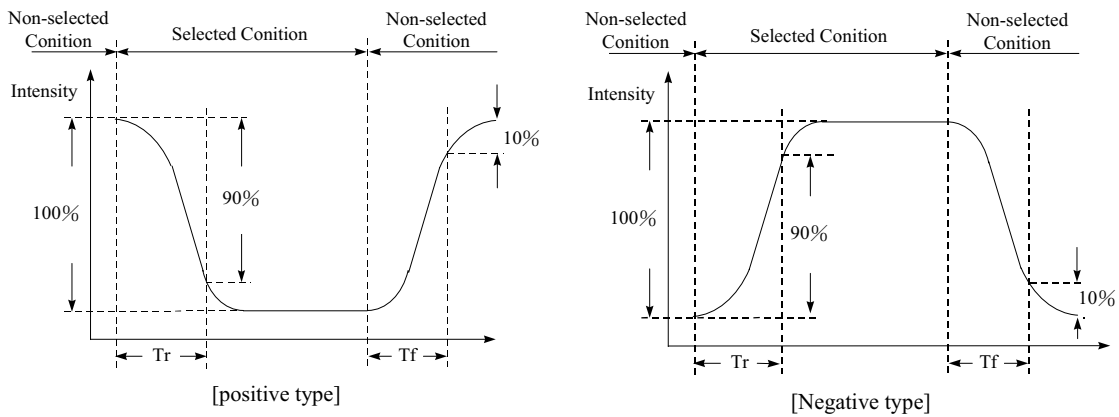

Conditions:

Operating Voltage : Vop
Frame Frequency : 64 Hz

Viewing Angle(θ , φ): 0° , 0°
Driving Wave form : 1/N duty, 1/a bias

[Note 9] Definition of Viewing Direction

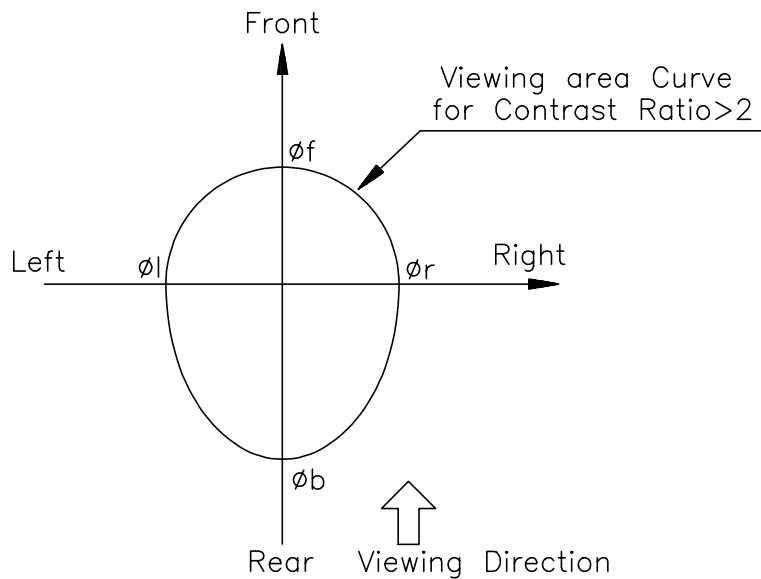

[Note 10] Definition of viewing angle

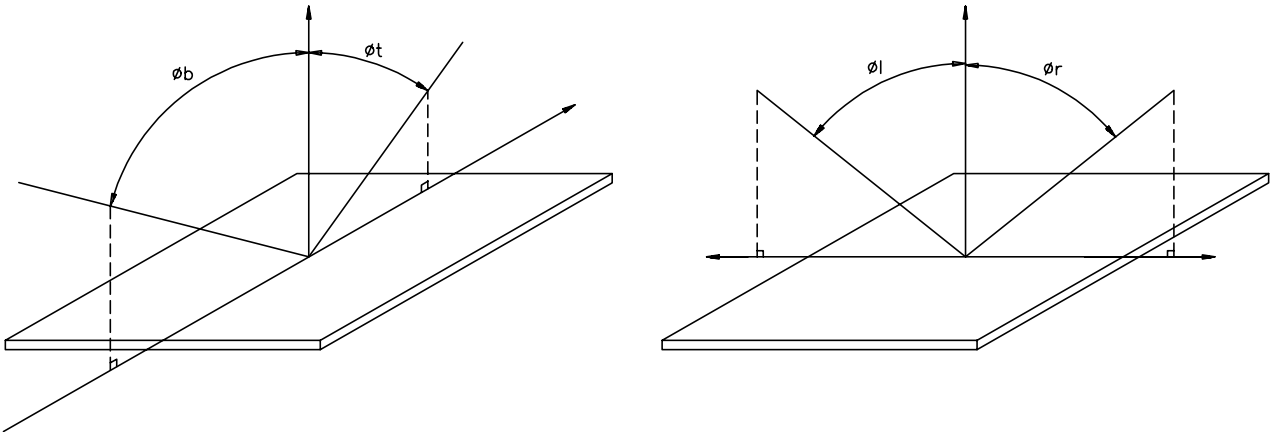

[Note 11] Description of Measuring Equipment

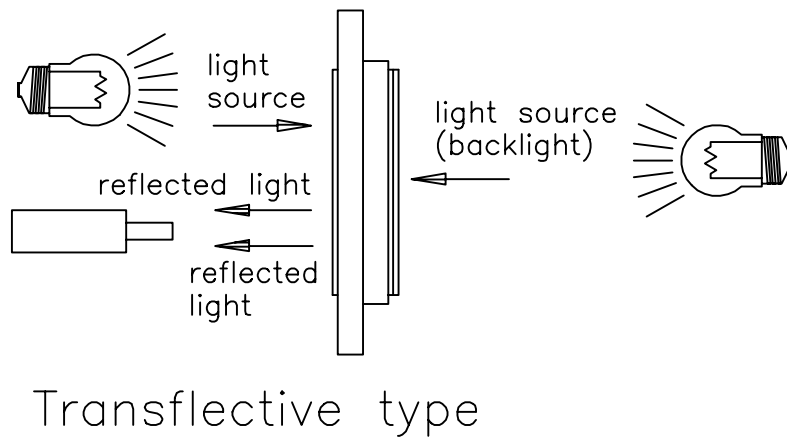
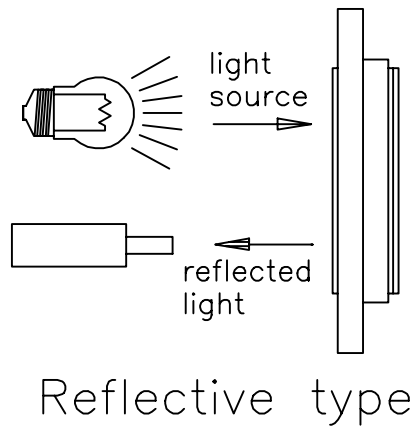

BLOCK DIAGRAM

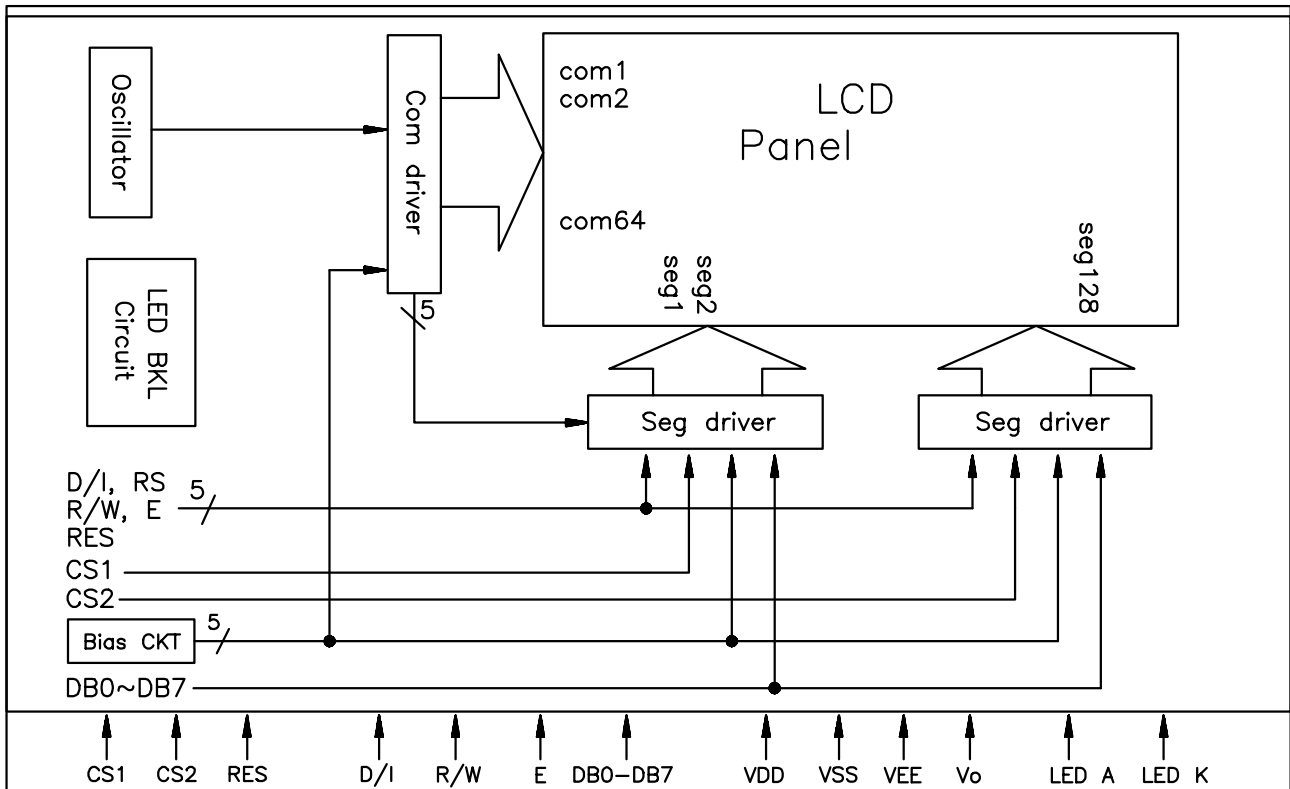

POWER SUPPLY

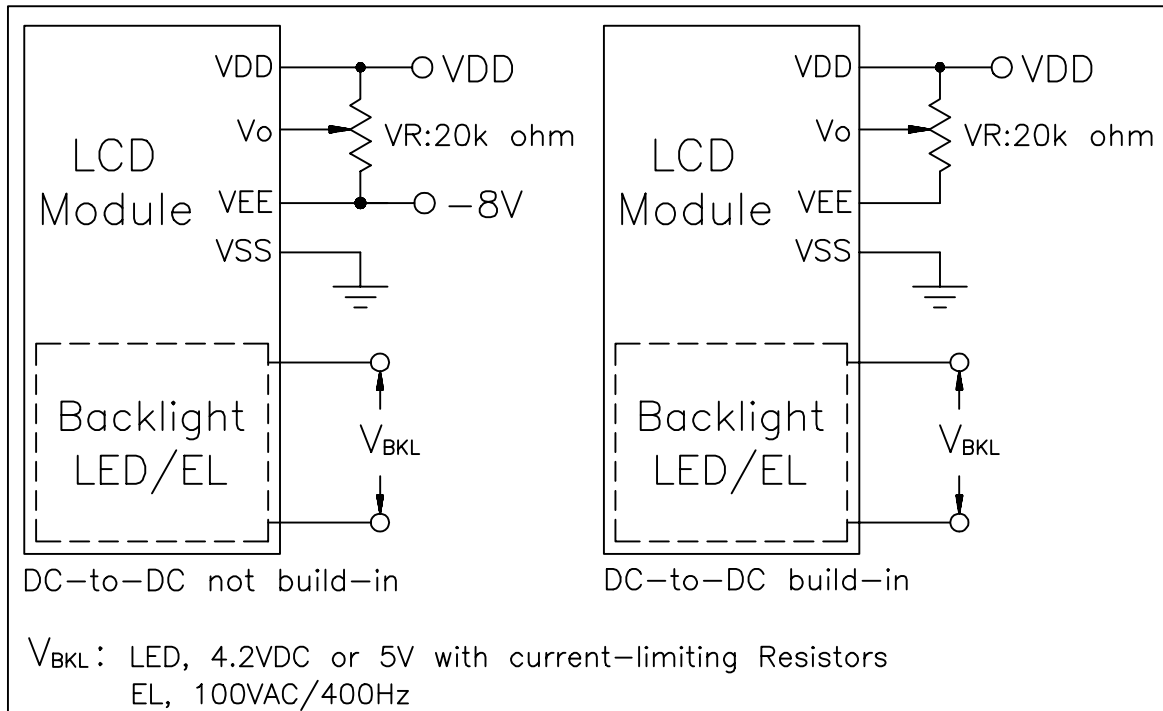

TIMING CHARACTERISTICS

MPU interface timing: ($V_{SS}=0V$, $V_{DD}=4.5V\sim 5.5V$, $T_a=0$ to $50^{\circ}C$)

Item	Symbol	Min.	Typ.	Max.	Unit
E Cycle Time	t_C	1000	—	—	ns
E High Level Width	t_{WH}	450	—	—	ns
E Low Level Width	t_{WL}	450	—	—	ns
E Rise Time	t_R	—	—	25	ns
E Fall Time	t_F	—	—	25	ns
Address Setup Time	t_{ASU}	140	—	—	ns
Address Hold Time	t_{AH}	10	—	—	ns
Data Setup Time	t_{DSU}	200	—	—	ns
Data Delay Time	t_D	—	—	320	ns
Data Hold Time(Write)	t_{DHW}	10	—	—	ns
Data Hold Time(Read)	t_{DHR}	20	—	—	ns

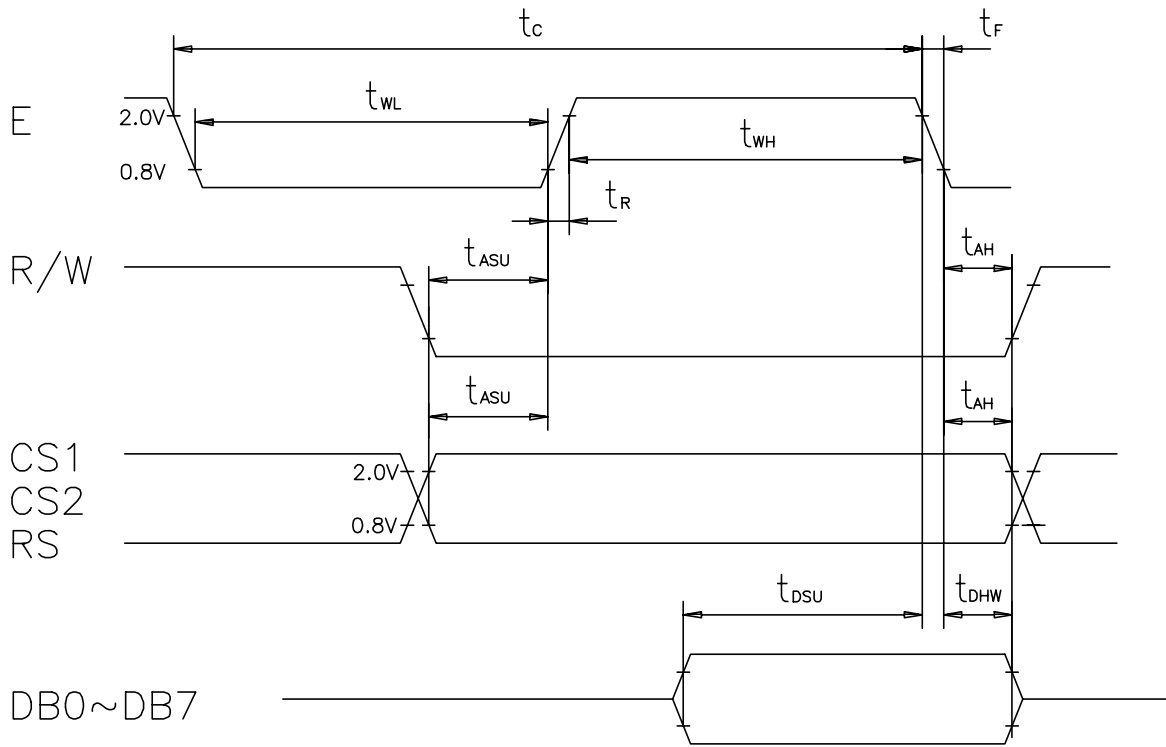

MPU Write Timing

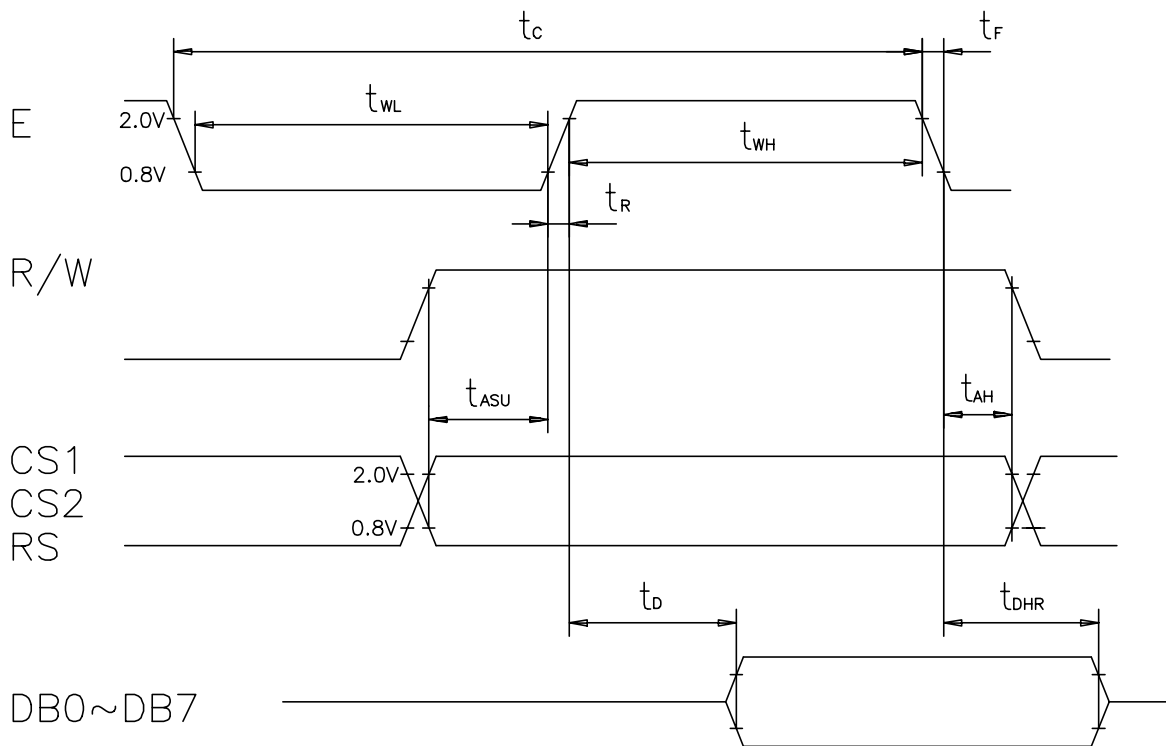

MPU Read Timing

DISPLAY COMMANDS

The display commands shown below control the internal state of the LCD driver ICs. Commands are sent from CPU to LCD module for the display control.

Command	RS	R/W	DB7	DB6	DB5	DB4	DB3	DB2	DB1	DB0	Function	
Display ON/OFF	0	0	0	0	1	1	1	1	1	1/0	To control the display ON or OFF. The internal status and display RAM data are not affected. 0:OFF, 1:ON	
Set address (Y address)	0	0	0	1	Y address (0~63)						To set the Y address in the Y address counter.	
Set page (X address)	0	0	1	0	1	1	1	Page(0~7)			To set the X address at the X address register.	
Display Start Line	0	0	1	1	Display Start Line(0~63)						To indicate the display data RAM displayed at the top of the screen.	
Status Read	0	1	Busy	0	ON/OFF	Reset	0	0	0	0	To read status of the LCD controller IC: Busy 0:Ready, 1: In operation ON/OFF: 0:Display ON, 1:Display OFF Reset: 0:Normal, 1:Reset	
Write display data	1	0	Write Data									To write data into display data RAM. Y address is increased by 1 after this command.
Read Display data	1	1	Read Data									To read data from display data RAM to the data bus.

MEMORY MAPPING

Relationship between RAM data and display

		RAM Y address(Y0 ~Y127)						Data							
1st page(X=0)	Line 0→	0	1	1	1	0	0	0	0	1	0	0	0	←DB0(LSB)
	Line 1→	1	0	0	0	1	0	0	0	1	1	0	0	←DB1
	Line 2→	1	0	0	0	1	0	0	0	1	0	1	0	←DB2
	Line 3→	1	0	0	0	1	0	0	0	1	0	1	0	←DB3
	1	1	1	1	1	0	0	0	1	0	0	0	←DB4
	1	0	0	0	1	0	1	1	1	0	0	0	←DB5
	1	0	0	0	1	0	1	1	1	0	0	0	←DB6
	Line 7→	0	0	0	0	0	0	0	0	0	0	0	0	←DB7(MSB)
2nd page(X=1)	Line 8→	1	1	1	1	0	0	0	1	1	1	0	0	←DB0(LSB)
	Line 9→	1	0	0	0	1	0	0	1	0	0	1	0	←DB1
	Line 10→	1	0	0	0	1	0	0	1	0	0	1	0	←DB2
	1	1	1	1	0	0	1	1	1	0	1	0	←DB3
	1	0	0	0	1	0	0	1	0	0	1	0	←DB4
	1	0	0	0	1	0	0	1	0	0	1	0	←DB5
	1	1	1	1	0	0	0	1	1	1	0	0	←DB6
	Line 15→	0	0	0	0	0	0	0	0	0	0	0	0	←DB7(MSB)
.....		
8th page(X=7)	Line 56→	1	0	0	0	1	0	0	0	0	0	0	0	←DB0(LSB)
	1	0	0	0	1	0	0	0	0	0	0	0	←DB1
	1	0	0	0	1	0	0	1	0	0	1	0	←DB2
	1	1	1	1	1	0	1	0	1	0	1	0	←DB3
	1	0	0	0	1	0	1	0	0	1	0	0	←DB4
	1	0	0	0	1	0	1	0	0	1	0	0	←DB5
	Line 62→	1	0	0	0	1	0	0	1	1	0	1	0	←DB6
	Line 63→	0	0	0	0	0	0	←DB7(MSB)

ADDRESS CONFIGURATION OF DISPLAY DATA RAM

		Y address								
		0	1	2	3	126	127		
X=0→	DB0	Page0						Line0	To	
	DB7							Line7	To	
X=1→	DB0	Page1						Line8	To	
	DB7							Line15	To	
X=2→	DB0	Page2						Line16	To	
	DB7							Line23	To	
X=3→	DB0	Page3						Line24	To	
	DB7							Line31	To	
X=4→	DB0	Page4						Line32	To	
	DB7							Line39	To	
X=5→	DB0	Page5						Line40	To	
	DB7							Line47	To	
X=6→	DB0	Page6						Line48	To	
	DB7							Line55	To	
X=7→	DB0	Page7						Line56	To	
	DB7							Line63	To	

Address configuration of Display Data RAM

RELIABILITY TEST

No	Item	Conditions		Note
1	High Temp. Operation	50°C	240 HR	
2	High Temp. Storage	70°C	240 HR	
3	Low Temp. Operation	0°C	240 HR	
4	Low Temp. Storage	-20°C	240 HR	
5	High Temp./Humid Storage	40°C 90%RH	240 HR	
6	Thermal Shock	0°C ,30min +50°C ,30min	10 cycles	
7	Vibration Test (IEC-68-2-6)	Frequency : 10~55 Hz Duration : 20 times, 6 min/time Amplitude : 0.75 mm	-	
8	Shock (IEC 68-2-27)	Duration : 11 mS Acceleration : 100g	-	X, Y, Z direction

APPEARANCE CHECK

CONDIITON OF APPEARANCE CHECK:

- (1) Specimen shall be checked by eyes in distance of 30cm under 40w-fluorescence lamp.
- (2) Checking direction shall be in 45 degree from perpendicular line op specimen surface.

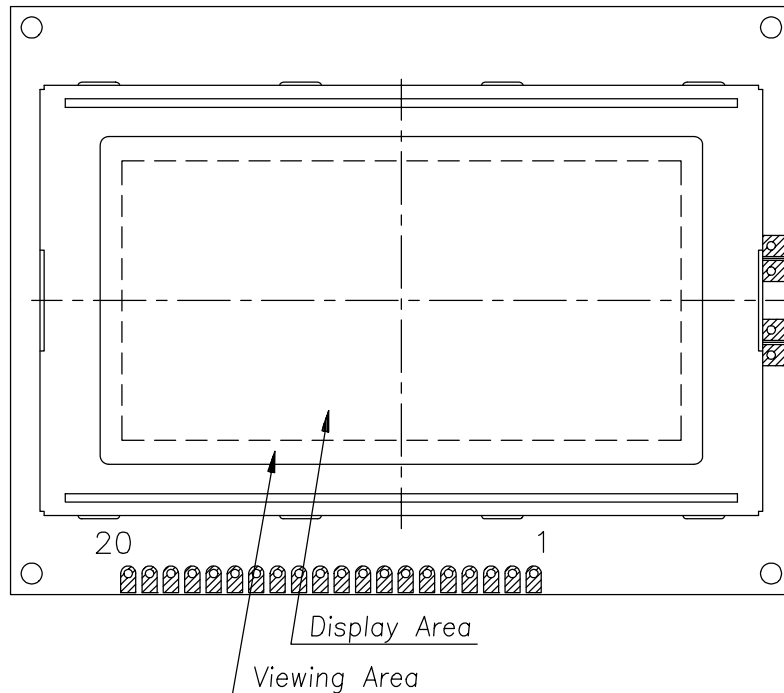

HANDLING PRECAUTIONS

- (1) Treat polarizer very carefully since it is easy to be damaged.
- (2) When cleaning the display surface, use soft cloth (e.g. gauss) with a solvent (recommended below) and wipe lightly.

- ◆ ethyl alcohol
- ◆ iso-procolol

Do not wipe the display surface with dry or hard materials that will damage the polarizer surface.

Do not use the following solvents:

- ◆ water
- ◆ ketone
- ◆ aromatics

- (3) Direct current causes electro-chemical reaction with remarkable degradation of the display quality. Give careful consideration to prevent direct current at ON/OFF timing and during operation.
- (4) Avoid strong shock and drop from the height.
- (5) To prevent LCD panels from degradation, do not operate or store them exposed directly to sunshine or high temperature/humidity.
- (6) Give careful consideration to avoid electrical static discharge with causes uneven contrast.
- (7) Even a small condensation on the contact pads (terminals) causes electro-chemical reaction which makes missing row and column. Give careful attention to avoid condensation. When assembling with zebra connector, clean the surface of the pads with alcohol and keep the air very clean.

LCD PRODUCT QUALITY STANDARD

DISPLAY APPEARANCE

No	Item	Criteria
1	inclusions (black spot, white spot, dust)	(1)round type diameter mm(a*) no of defect* $a \leq 0.20$ neglect $0.20 < a \leq 0.35$ 5max $0.35 < a$ none (2)linear type length mm(l) width mm(W) no. of defect na $W \leq 0.03$ neglect $1 \leq 3$ $0.03 < W \leq 0.08$ 6 $3 < l$ $0.08 < W$ none
2	scratch	1. scratch on protective film is permitted. 2. scratch on polarizer shall be as follow: (1)round type diameter mm(a*) no of defect $a \leq 0.15$ neglect $0.15 < a \leq 0.20$ 2 max $0.20 < a$ none (2)linear type be judged bye 1.-(2) linear type
3	dent	diameter < 1.5mm
4	bubble	not exceeding 0.5mm average diameter is acceptable between glass and polarizing film
5	pin hole	$(a+b)/2 \leq 0.15\text{mm}$ maximum number: ignored $0.15 < (a+b)/2 \leq 0.20\text{mm}$ maximum number:10
6	dot defect	$(a+b)/2 \leq 0.20\text{mm}$ maximum number: ignored $0.20 < (a+b)/2 \leq 0.30\text{mm}$ maximum number:5 x=width
7	contrast irregularity(spot)	diameter spec no of defect $a \leq 0.50\text{mm}$ neglect $0.50 < a \leq 0.75$ 5 $0.75 < a \leq 1.00$ 3 $1.00 < a$ none
8	dot width	design width $\pm 15\%$
9	color tone and uniformity	obvious uneven color is not permitted

