



B106 Rotary Encoder



User's Manual

V1.2

January 2010

Information contained in this publication regarding device applications and the like is intended through suggestion only and may be superseded by updates. It is your responsibility to ensure that your application meets with your specifications. No representation or warranty is given and no liability is assumed by Cytron Technologies Incorporated with respect to the accuracy or use of such information, or infringement of patents or other intellectual property rights arising from such use or otherwise. Use of Cytron Technologies's products as critical components in life support systems is not authorized except with express written approval by Cytron Technologies. No licenses are conveyed, implicitly or otherwise, under any intellectual property rights.

Index

1. Introduction	3
2. Specification	3
3. Pin Configuration	4
4. Theory of Operation	4
5. Connecting to Controller	7
6. Connecting to Mechanism	8
7. Warranty	10

1. INTRODUCTION

Rotary Encoder is designed to provide pulse feedback when the shaft is rotated. Cytron offers low cost yet compact and high quality rotary encoder. This incremental rotary encoder has the following features:

- **Incremental** feedback
- Small size
- Light weight
- Easy installation
- Outer diameter 25mm
- Shaft diameter 4mm
- Operating at precise condition
- Side entry cable
- Wide operating range, from **5V to 24V**
- Provide 3 outputs, **OUT A, OUT B and OUT Z**
- **500 pulse per rotation**
- 1 meter cable length
- **NPN open collector** output

2. SPECIFICATION

Technical Parameters

Parameter	Value
Operating Voltage	DC + 5V to 24V
Output Voltage	NPN open collector (require pull-up)
Current consumption	~120 mA
Maximum Pulse	100 KHz
Output wave form	Square wave
Starting torque	1.5×10^{-3} Nm(at 25°C)
Moment of inertia	3.5×10^{-6} kgm ²
Max allowable load	Radial direction = 20N, Axial direction = 10N
Maximum shaft speed	6000 rpm
Vibration resistance	50m/s ² 10-200Hz, X, Y, Z directions 2H
Shock resistance	980m/s ² 6ms, X, Y, Z directions twice
Protection	IP54
Life span	MYBF>10000 hours (25°C, 2000 rpm)
Operating temperature	-10°C to +70°C
Storage temperature	-30°C to +85°C
Operating humidity	30 to 85% without frost
Mass	~ 100 gram

3. PIN CONFIGURATION

Cable Connection

Cable color	Red	Black	Blue	White	Yellow
Signal	DC +5V to +24V	Gnd	OUT A	OUT B	OUT Z
Function	Input Voltage	Ground	Digital Output	Digital Output	Digital Output

4. THEORY OF OPERATION

The cable comes with shielded wire which has been connected to rotary encoder shell. User may connect this shield wire to system ground.

The cable length is 1 meter. However it may be extended to maximum 100 meters.

Theory of Operation:

- This rotary encoder belongs to high accuracy instrumentation. Please **DO NOT** beat, twist or strike with hammer or other objects during installation of the rotary encoder. Otherwise, it will greatly affect the accuracy of performance and life span of this rotary encoder.
- To reinforce and prevent rigidity from linking, user should adopt flexible shaft coupling.
- Do pay attention to the maximum load allowed for the shaft during installation and operation.
- Wrong voltage input or wrong connection of interfacing circuit will damage the rotary encoder.

Rotary encoder is used to calculate the rotation of the shaft. Depending on the pulse per rotation, user may encode the angle by counting the accumulative pulse. However, this rotary encoder can also detect the direction of rotation by combining 2 signals, OUT A and OUT B. When the shaft of rotary encoder rotates in the clockwise direction, OUT A will lead OUT B by 90°. If the shaft rotates in counter clockwise direction, OUT B will lead OUT A by 90°. By checking the phase of both OUT A and OUT B, user will know the direction of shaft rotation. Following figures show example of output pulse generated from OUT A and OUT B, with 2 different rotating directions. OUT Z will output a single pulse for each rotation of rotary encoder.

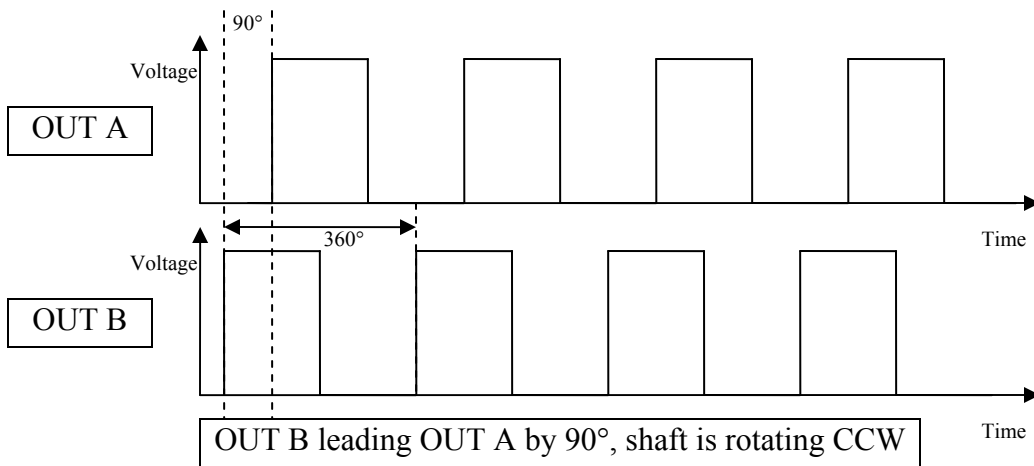
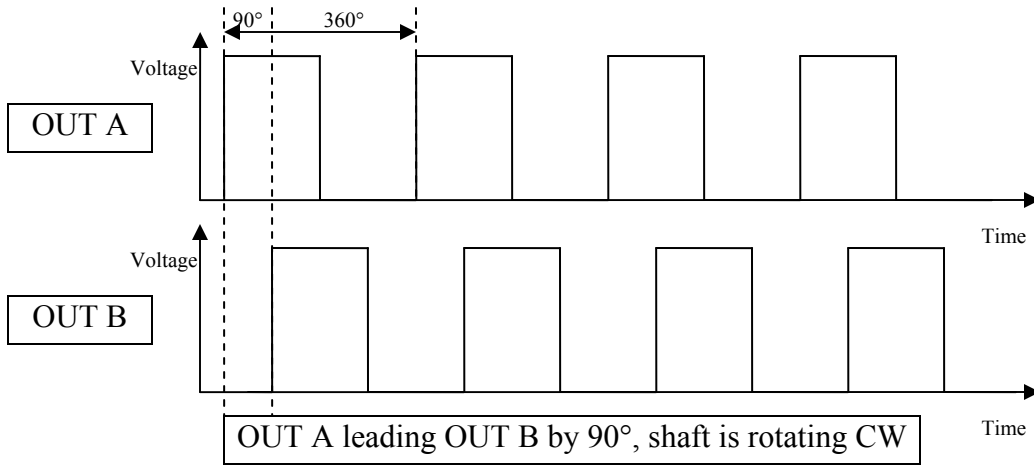

As stated above, rotary encoder can be used to feedback distance. Combining with a roller, distance of certain movement or locomotion can be obtained. Referring to following figure and mathematical equations, user may acquire the distance.

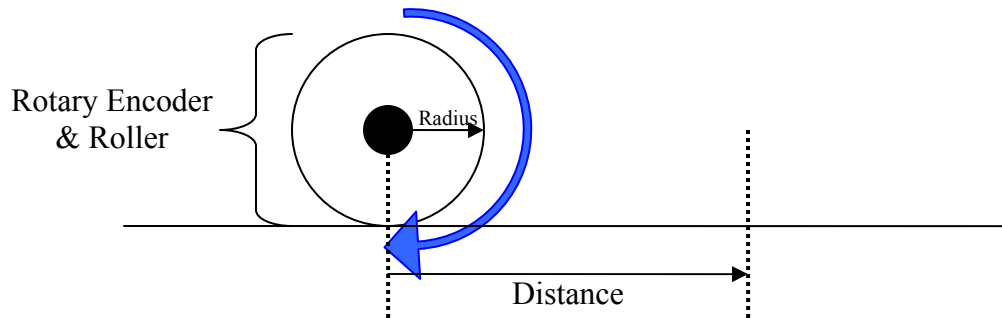

With the radius of roller and the pulses generated from rotary encoder, the perimeter of the roller can be obtained. The distance is equal to perimeter of roller. For example:

- If the Radius of roller, $r = 2$ cm
- Pulse accumulated after rotation, $p = 250$ pulses
- Pulse for a full rotation of rotary encoder, $P = 500$ pulses

$$\begin{aligned} \text{Perimeter} &= 2\pi r \left(\frac{p}{P}\right) \dots\dots\dots \text{(Where } \pi \text{ is pi, } r \text{ is radius)} \\ &= 2 (3.142) (2 \text{ cm}) (250/500) \\ &= 6.284 \text{ cm} \end{aligned}$$

Thus the Distance, D equals to Perimeter = 6.284 cm

5. CONNECTING TO CONTROLLER

Generally, the output of a rotary encoder is connected to a processor to obtain the feedback from certain mechanism such as motor, lifting mechanism and etc. There is no limitation on which processor, microprocessor and microcontroller to connect to, as long as the processor can detect pulse. This document will show an example of interface between this rotary encoder and PIC MCU.

Since the input voltage range of rotary encoder start from 5V to 24V, user has several options of power sources for rotary encoder. User may connect regulated 5V from regulator (which will share with PIC MCU) or higher voltage from battery or adaptor such as 9V or 12V battery.

The output of rotary encoder is open collector (NPN) type; a pull-up resistor to high state of logic voltage is required. As an example, if PIC MCU is used and the logic voltage is 5V and 0V, thus user need to pull the output of rotary encoder with a 1K to 10K resistor to 5V. This is to ensure the pulse generated is 5V and 0V. If the processor is a PLC where the logic is 24V, user will need to pull the resistor to 24V in order to receive 24V and 0V pulse. Depending on applications, user may use one, two or all three outputs from the rotary encoder. As for the ground of rotary encoder, it should be connected to system ground, or at least the same ground with the processor. The following figure show an example of rotary encoder connected to PIC MCU.

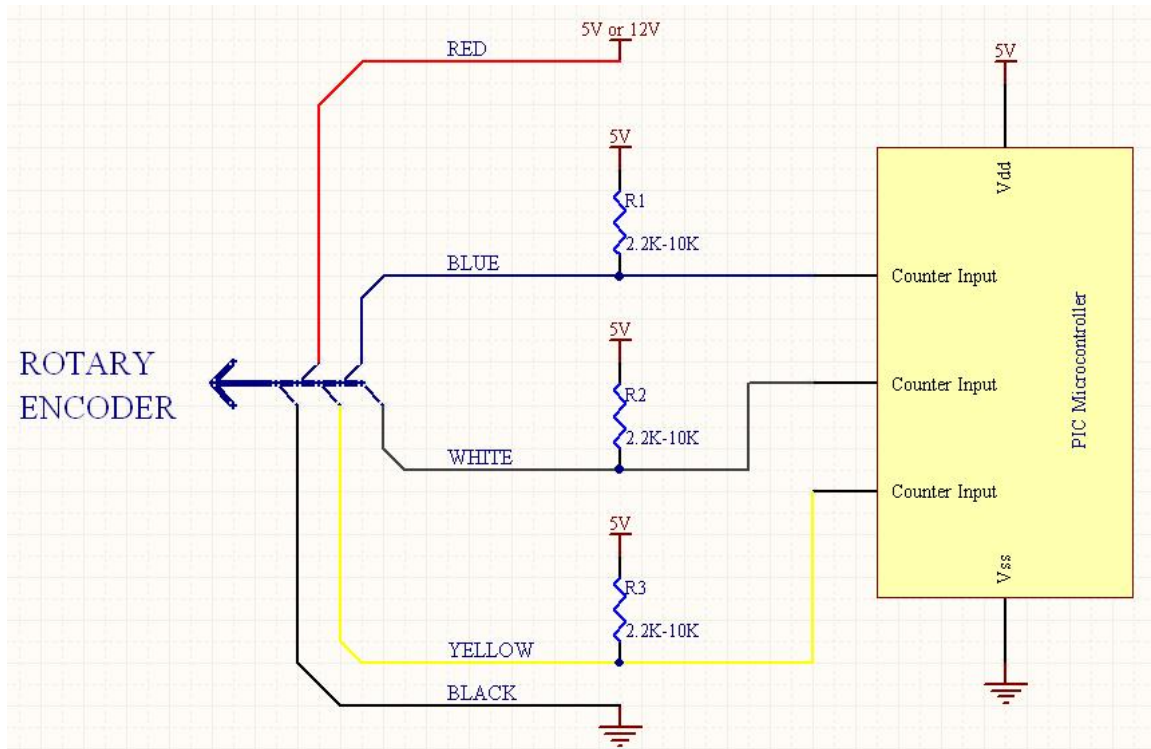

Rotary Encoder to PIC Microcontroller

6. CONNECTING TO MECHANISM

Since this rotary encoder is a high accuracy instrument, care is required during installation. This rotary encoder can be connected to rotating shafting of motor using flexible shaft coupling. Connecting directly to motor shaft will offer the feedback of rotation angle of motor shaft. Following figure show picture of flexible shaft coupling.



Flexible shaft coupling

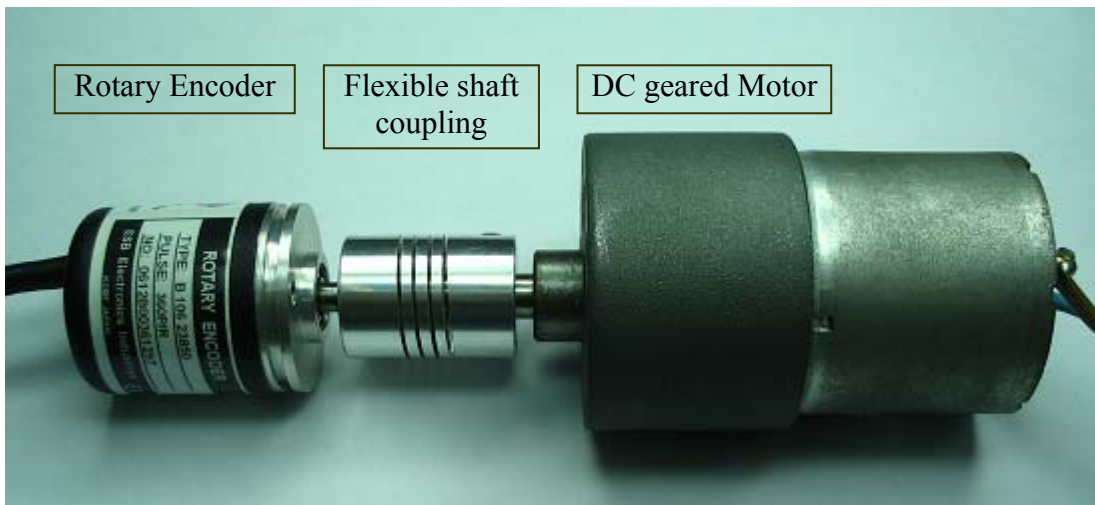

Rotary encoder connected to DC geared motor using flexible shaft coupling.

Rotary encoder can also be used to offer feedback of distance if it is connected to mechanism such as lifting, car body and etc. In this case, a roller should be used. Following figures show roller or wheel and the mounting.

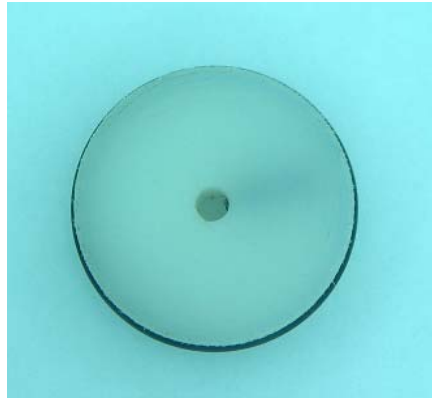

Roller or wheel.



Rotary encoder connected to roller or wheel.

7. WARRANTY

- Product warranty is valid for 6 months
- Warranty only applies to factory defect.
- Damage caused by mis-use is not covered under warranty.
- Warranty does not cover freight cost for both ways.

Prepared by
Cytron Technologies Sdn. Bhd.
19, Jalan Kebudayaan 1A,
Taman Universiti,
81300 Skudai,
Johor, Malaysia.

Tel: +607-521 3178

Fax: +607-521 1861

URL: www.cytron.com.my
Email: support@cytron.com.my
sales@cytron.com.my